

# Drives Accessories – Output Filters for Multiple AC Drives

## VTF Series Drive Output Filters

Extend the life of your motors and cables by reducing the harmful effects of voltage spikes due to voltage wave reflection. Voltage wave reflection is a function of the voltage rise time (dv/dt) and the length of the motor cables.

AutomationDirect VTF series drive output filters protect motors and cables by combining a patented dampening circuit with a low pass filter to increase the voltage rise time (dt out of dv/dt), thereby preventing voltage spikes from exceeding 1,000V.

The impedance values on each end of the cable run don't match, causing voltage pulses to be reflected back in the direction from which it arrived. As these reflected waves encounter other waves, their values add, causing higher peak voltage.

As wire length or carrier frequency increases, the overshoot peak voltage also increases.

Peak voltages on a 480V system can reach 1,600V, and 2,100V on a 600V system. These high peak voltages can cause a rapid breakdown of motor insulation, leading to motor failure.

### Features:

- Protect cable runs and reduce motor heating, noise, and vibration.
- Prevent motor failure with protection against motor insulation breakdown.
- Reduce Common Mode Noise by a minimum of 30%.
- Improve system productivity and increase bearing life and up-time.
- Protect long motor lead lengths up to 1,000 feet.
- Carrier Frequency: 2–4 kHz
- Efficiency  $\geq$  98%
- 208 - 600 VAC system compatibility
- Operation up to 60Hz output drive frequency.
- Warranty: One (1) year of useful service, not to exceed 18 months from the date of shipment.
- Over-Load Rating 200% rated current for 2 minutes per hour 150% rated current for 5 minutes per hour.

### Agency Approvals:

- cUL<sub>US</sub> listed (E197592)



**VTF-246-CFG-N1**

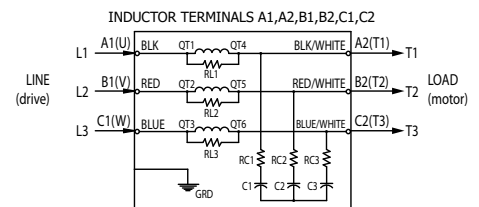

(Customer Connections)  
Markings On Terminal Block  
For Reference Only

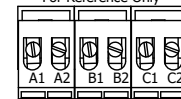

- For CFW100 drive compatibility, please refer to WEG CFW100 AC Drives - Accessories: [PDF](#).
- For CFW300 drive compatibility, please refer to WEG CFW300 AC Drives - Accessories: [PDF](#).
- For CSW500 drive compatibility, please refer to WEG CSW500 AC Drives - Accessories: [PDF](#).
- For GS4 drive compatibility, please refer to GS4 Drives Accessories-Line/Load Reactors: [PDF](#).
- For GS10 drive compatibility, please refer to GS10 Drives Accessories-Line Reactors: [PDF](#).
- For GS20(X) drive compatibility, please refer to GS20(X) Accessories-Line Reactors/VTF Filters: [PDF](#).
- For GS30 drive compatibility, please refer to GS30 Accessories-Line Reactors/VTF Filters: [PDF](#).
- For AS3 drive compatibility, please refer to AS3 Accessories-Line Reactors/VTF Filters: [PDF](#).



Output Filters are impregnated with 100% solid epoxy resin. All insulation varnish systems are rated H (180°C) or class R (220° C), 600V. (Class H up to 110A VTF-246-RUV; Class R from 130A Up VTF-246-SVW)

# Drives Accessories – Output Filters for Multiple AC Drives

Drive Output Filters – VTF Series – for Multiple AC Drives														
Part Number	Price	Filter Specs		Applicable Motor Sizes*				Phases	Watt Loss	Wire Size [AWG]	Terminal Torque [lb-in]	Fasteners	Weight [lb]	Drawing Links
		Rated Voltage	Max Rated Amps	208V Rated HP	230V Rated HP	460V Rated HP	575V Rated HP							
<a href="#">VTF-46-DE</a>	\$368.00	208-600 VAC	2A	-	-	3/4	1	3	75	12-14	10	6/40 x 5/16 flathead	8	<a href="#">PDF</a>
<a href="#">VTF-246-CFG</a>	\$374.00		3A	1/2	1/2	1-1/2	2						12	<a href="#">PDF</a>
<a href="#">VTF-246-CFG-N1</a>	\$578.00		4A	3/4	3/4	2	3						8	<a href="#">PDF</a>
<a href="#">VTF-246-DGH</a>	\$378.00		6A	1	1-1/2	3	-						12	<a href="#">PDF</a>
<a href="#">VTF-24-FH</a>	\$387.00		8A	2	2	5	5						8	<a href="#">PDF</a>
<a href="#">VTF-24-FH-N1</a>	\$591.00		12A	3	3	7-1/2	10						12	<a href="#">PDF</a>
<a href="#">VTF-246-GJJ</a>	\$394.00		16A	-	5	-	-						8	<a href="#">PDF</a>
<a href="#">VTF-246-GJJ-N1</a>	\$605.00		18A	5	-	10	15						12	<a href="#">PDF</a>
<a href="#">VTF-246-HKL</a>	\$408.00		21A	-	-	-	-						15	<a href="#">PDF</a>
<a href="#">VTF-246-HKL-N1</a>	\$632.00		25A	7-1/2	7-1/2	15	20						12	<a href="#">PDF</a>
<a href="#">VTF-24-JL</a>	\$394.00		27A	-	-	20	25						16	<a href="#">PDF</a>
<a href="#">VTF-46-LM</a>	\$492.00		35A	10	10	25	30						14	<a href="#">PDF</a>
<a href="#">VTF-46-LM-N1</a>	\$665.00		45A	-	15	30	40						15	<a href="#">PDF</a>
<a href="#">VTF-4-M</a>	\$501.00		55A	15	20	40	50						17	<a href="#">PDF</a>
<a href="#">VTF-246-KMN</a>	\$525.00		80A	20	30	60	75						25	<a href="#">PDF</a>
<a href="#">VTF-246-KMN-N1</a>	\$705.00		110A	30	40	75	100						26	<a href="#">PDF</a>
<a href="#">VTF-46-NP</a>	\$536.00		130A	40	50	100	125						25	<a href="#">PDF</a>
<a href="#">VTF-46-NP-N1</a>	\$717.00		160A	60	125	150	200						23	<a href="#">PDF</a>
<a href="#">VTF-246-LPQ</a>	\$569.00		200A	75	150	200	250						31	<a href="#">PDF</a>
<a href="#">VTF-246-LPQ-N1</a>	\$731.00		250A	-	100	200	250						31	<a href="#">PDF</a>
<a href="#">VTF-246-MQR</a>	\$591.00		305A	-	250	300	300						26	<a href="#">PDF</a>
<a href="#">VTF-246-MQR-N1</a>	\$754.00		362A	150	300	350	350						26	<a href="#">PDF</a>
<a href="#">VTF-246-NRS</a>	\$611.00												26	<a href="#">PDF</a>
<a href="#">VTF-246-NRS-N1</a>	\$821.00												26	<a href="#">PDF</a>
<a href="#">VTF-246-PSU</a>	\$834.00												26	<a href="#">PDF</a>
<a href="#">VTF-246-PSU-N1</a>	\$1,071.00												26	<a href="#">PDF</a>
<a href="#">VTF-246-RUV</a>	\$1,012.00												26	<a href="#">PDF</a>
<a href="#">VTF-246-RUV-N1</a>	\$1,331.00												26	<a href="#">PDF</a>
<a href="#">VTF-246-SVW</a>	\$1,181.00												26	<a href="#">PDF</a>
<a href="#">VTF-246-SVW-N1</a>	\$1,655.00												26	<a href="#">PDF</a>
<a href="#">VTF-246-TWX</a>	\$1,303.00												26	<a href="#">PDF</a>
<a href="#">VTF-246-TWX-N1</a>	\$1,777.00												26	<a href="#">PDF</a>
<a href="#">VTF-246-UXY</a>	\$1,420.00												26	<a href="#">PDF</a>
<a href="#">VTF-246-UXY-N1</a>	\$1,851.00												26	<a href="#">PDF</a>
<a href="#">VTF-246-VYZ</a>	\$1,458.00												26	<a href="#">PDF</a>
<a href="#">VTF-246-VYZ-N1</a>	\$1,887.00												26	<a href="#">PDF</a>
<a href="#">VTF-46-ZI</a>	\$1,584.00												26	<a href="#">PDF</a>
<a href="#">VTF-46-ZI-N1</a>	\$1,898.00												26	<a href="#">PDF</a>
<a href="#">VTF-246-XIO</a>	\$1,816.00												26	<a href="#">PDF</a>
<a href="#">VTF-246-XIO-N1</a>	\$2,113.00												26	<a href="#">PDF</a>

\* - Motor HP ratings by voltage are based on NEC currents. For voltages with no HP listed, pick the VTF with max rated amps slightly higher than the application motor amp rating.

Properly sized and applied, the manufacturer guarantees that the VTF will limit motor terminal peak input voltage to 150% of the bus voltage with a wire lead length of 1,000 feet and a carrier frequency of 4 kHz. Maximum lead length and carrier frequency can vary depending on wire lead type. If a properly selected, installed, and loaded VTF filter fails to meet the guaranteed performance levels, the manufacturer will provide the necessary components or replacement filter at no additional charge. The manufacturer does not take responsibility for additional installation or removal costs, to include, but not limited to, replacement of third-party equipment.

Minimum System Requirements for Guarantee – In order to achieve the performance levels as stated in this guarantee, the electrical system must adhere to the following: The VTF must be sized at no more than 110% of the drive output current rating. If the load has a potential for overhauling, the drive must be equipped with braking resistors or other features limiting bus voltage to no more than the level of the peak line voltage. The VTF must be wired no more than 10 feet from the drive.



# GS/DURAPULSE Drives Accessories – Line/Load Reactors

## Line/Load Reactors for GS/DURAPULSE AC Drives – Additional Specifications

Line Reactors – LR Series – Additional Specifications							
Part Number	Price	Product Weight	Wire Range	Terminal Torque	Temperature Range		Environment
					Operating	Storage	
<u>LR-20P5</u>	Retired	4.0 lb [1.8 kg]	#12–#18 AWG	10 lb·in	-40 – 104 °F [-40 – 40 °C]	-40 – 149 °F [-40 – 65 °C]	NEMA: open IP00 no corrosive gases
<u>LR-21P0-1PH</u>	\$78.00	2.8 lb [1.3 kg]	#12–#18 AWG	10 lb·in			
<u>LR-22P0-1PH</u>	\$86.00	4.3 lb [2.0 kg]	#12–#18 AWG	20 lb·in			
<u>LR-23P0-1PH</u>	Retired	4.3 lb [2.0 kg]	#12–#18 AWG	20 lb·in			
<u>LR-23P0</u>	Retired	4.0 lb [1.8 kg]	#12–#18 AWG	10 lb·in			
<u>LR-25P0</u>	\$194.00	8.0 lb [3.6 kg]	#18–#4 AWG	20 lb·in			
<u>LR-27P5</u>	\$206.00	8.0 lb [3.6 kg]	#18–#4 AWG	20 lb·in			
<u>LR-2010</u>	\$242.00	12 lb [5.4 kg]	#18–#4 AWG	20 lb·in			
<u>LR-2015</u>	\$285.00	12 lb [5.4 kg]	#18–#4 AWG	20 lb·in			
<u>LR-2020</u>	\$312.00	12 lb [5.4 kg]	#18–#4 AWG	20 lb·in			
<u>LR-2025</u>	\$460.00	15 lb [6.8 kg]	#18–#4 AWG	#18–#16 AWG: 25 lb·in #14–#6 AWG: 30 lb·in #4 AWG: 35 lb·in			
<u>LR-2030</u>	\$490.00	33 lb [15 kg]	2/0 – #6AWG (AL or CU)	120			
<u>LR-2040</u>	\$574.00	33 lb [15 kg]	2/0 – #6AWG (AL or CU)	120			
<u>LR-2050</u>	\$670.00	36 lb [16 kg]	250kcmil – #6AWG (AL or CU)	275			
<u>LR-4010</u>	Retired	4.0 lb [1.8 kg]	#12–#18 AWG	10 lb·in			
<u>LR-4015</u>	\$237.00	8.0 lb [3.6 kg]	#18–#4 AWG	20 lb·in			
<u>LR-4020</u>	\$276.00	8.0 lb [3.6 kg]	#18–#4 AWG	20 lb·in			
<u>LR-4025</u>	\$290.00	10 lb [4.5 kg]	#18–#4 AWG	20 lb·in			
<u>LR-4030</u>	\$347.00	10 lb [4.5 kg]	#18–#4 AWG	20 lb·in			
<u>LR-4040</u>	\$382.00	15 lb [6.8 kg]	#18–#4 AWG	20 lb·in			
<u>LR-4050</u>	\$448.00	25 lb [11 kg]	#22–#4 AWG	#22–#16 AWG: 25 lb·in #14–#6 AWG: 30 lb·in #4 AWG: 35 lb·in			
<u>LR-4060</u>	\$462.00						
<u>LR-4075</u>	\$700.00	33 lb [15 kg]	2/0 – #6AWG (AL or CU)	120 lb·in			
<u>LR-4100</u>	\$840.00	46 lb [21 kg]	250kcmil – #6AWG (AL or CU)	275 lb·in			
<u>LR-4125</u>	\$962.00	46 lb [21 kg]	250kcmil – #6AWG (AL or CU)	275 lb·in			
<u>LR-4150</u>	\$1,114.00	46 lb [21 kg]	250kcmil – #6AWG (AL or CU)	275 lb·in			
<u>LR-4200</u>	\$1,238.00	74 lb [34 kg]	(1) 600kcmil – #4 AWG (2) 250kcmil – 1/0	500 lb·in			
<u>LR-4250</u>	\$1,403.00	74 lb [34 kg]	(2)* 350kcmil – #4 AWG (AL or CU)	275 lb·in			
<u>LR-4300</u>	\$1,546.00	74 lb [34 kg]	(2)* 350kcmil – #4 AWG (AL or CU)	275 lb·in			
<u>LR-5010</u>	Retired	4.0 lb [1.8 kg]	#12–#18 AWG	10 lb·in			

\* LR-4250 & LR-4300 have dual-connector lugs, and will require multiple conductors per phase of the appropriate size to fit the lugs.