

# MCHA2 series

## 30° ANGULAR GRIPPER



Model selection



Technical data



Caution for safety  
(Read before installing)



### Features

- Hardened gripping fingers for longer service life.
- Simple structure with high stability.
- Magnetic as standard.

### Specification

Model		MCHA2					
Acting type		Double acting / Single acting (N.O.)					
Tube I.D. (mm)		12	16	20	25	32	
Port size		M3×0.5	M5×0.8				
Medium		Air					
Operating pressure range	Double acting	0.15~0.7 MPa					
	Single acting	0.3~0.7	0.2~0.7 MPa				
Ambient temperature		-5~+60°C (No freezing)					
Max. operating frequency (c.p.m)		180 (*1)					
Lubrication	Cylinder	Not required					
	Lever	Grease (Joint parts)					
Volume (cm <sup>3</sup> )	Finger open	Double acting	0.7	1.2	2.3	4.0	6.7
		Single acting	0.6	1.3	2.4	4.4	7.9
	Finger close	0.4	0.8	1.4	2.7	4.9	
Max. arm length (L) (*2)		30	40	60	70	85	
Clamp / Release angle		-10~+30°					
Sensor switch		RDC(V), RQC(V)					
Weight (g)		53	103	193	327	525	

\*1. Use tube I.D. 12 at max operating frequency will affect the service life.

\*2. L : Arm length (mm)

### Order example

MCHA2 - 20 - □

MODEL

TUBE I.D.

ACTING TYPE

Blank: Double acting  
S: Single acting (Normally open)

12  
16  
20  
25  
32

### Installation of sensor switch

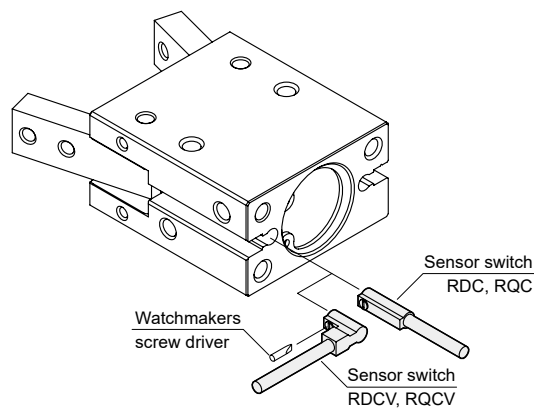

# MCHA2 Inside structure & Parts list

30° ANGULAR GRIPPER



mindman

## Double acting

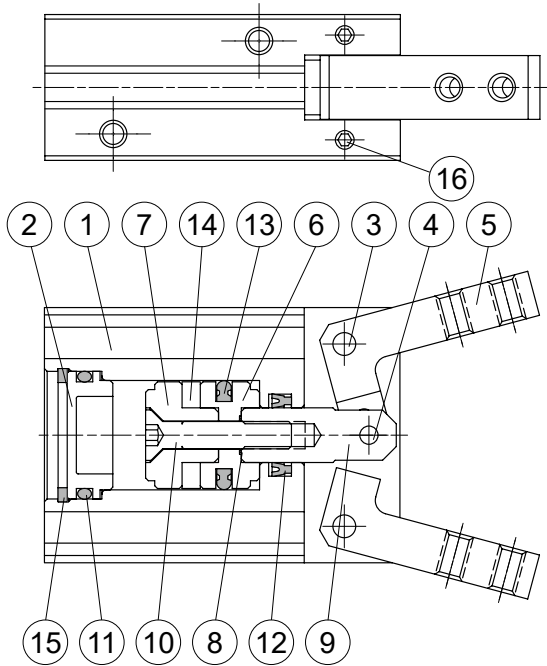

## Single acting

Normally Open

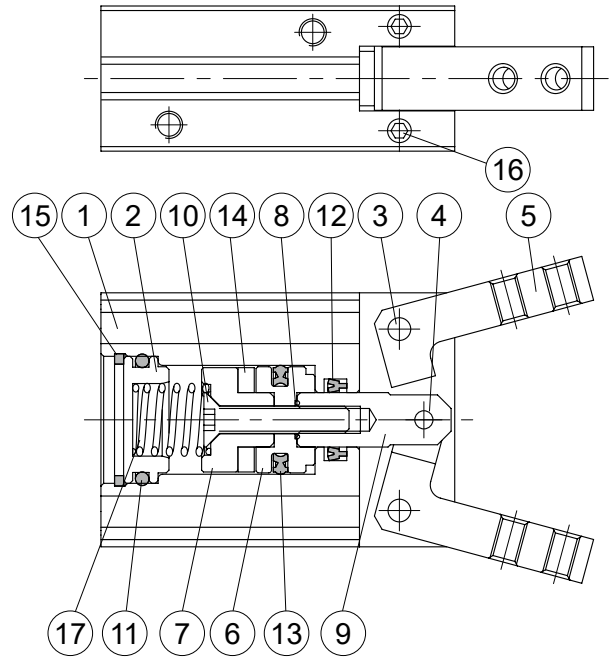

## Material

No.	Part name	Material	Q'y	Repair kits (inclusion)
1	Body	Aluminum alloy	1	
2	Head cover	Aluminum alloy	1	
3	Grip rivet	Carbon steel	2	
4	Spindle rivet	Bearing steel	1	
5	Y-finger	Medium carbon steel	2	
6	Piston-R	Aluminum alloy	1	
7	Piston-H	Aluminum alloy	1	
8	Gasket	NBR	1	●
9	Piston rod	Stainless steel	1	
10	Screw	Stainless steel	1	
11	Cover ring	NBR	1	●
12	Rod packing	NBR	1	●
13	Piston packing	NBR	1	●
14	Magnet ring	Magnet material	1	
15	Stop ring	Spring steel	1	
16	Screw	SCM	4	
17	Spring	Spring steel	1	

## Order example of repair kits

Tube I.D.	Repair kits
ø12	<b>PS-MCHA-12</b>
ø16	<b>PS-MCHA-16</b>
ø20	<b>PS-MCHA-20</b>
ø25	<b>PS-MCHA-25</b>
ø32	<b>PS-MCHA-32</b>

\* Use the same repair kits with MCHA series.

### Effective gripping force

Indication of effective force.  
The effective gripping force shown in the graphs to the right is expressed as F, which is the thrust of one finger, when both fingers and attachments are in full contact with the workpiece as shown in the figure below.

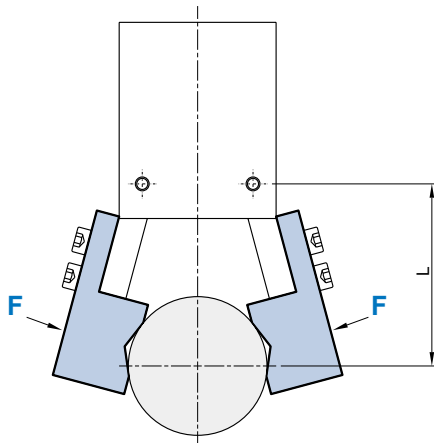

1N=0.102 kgf  
1MPa=10.2 kgf/cm<sup>2</sup>

### Double acting

#### MCHA2-12

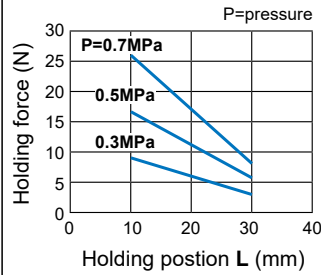

#### MCHA2-16

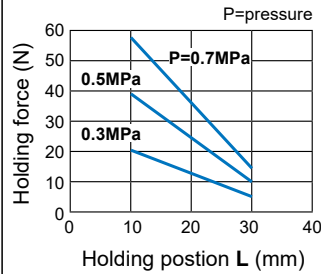

#### MCHA2-20

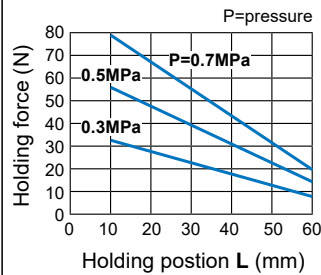

#### MCHA2-25

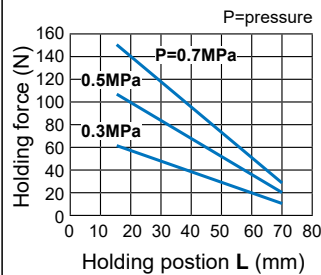

#### MCHA2-32

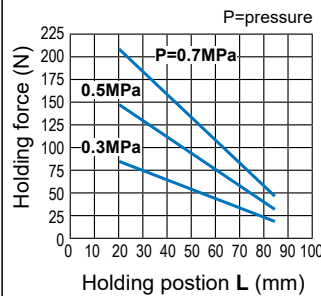

### Single acting (Normally open)

#### MCHA2-12-S

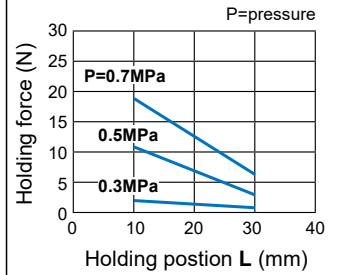

#### MCHA2-16-S

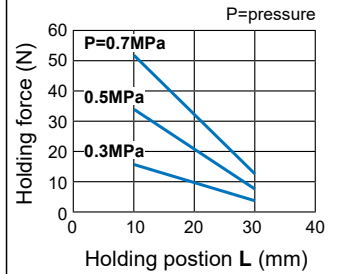

#### MCHA2-20-S

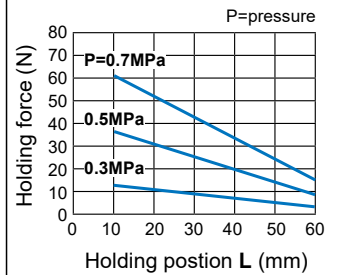

#### MCHA2-25-S

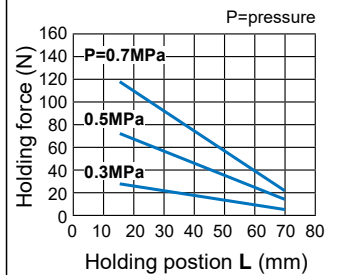

#### MCHA2-32-S

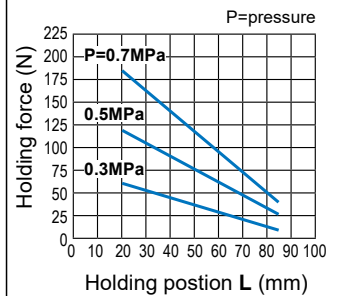

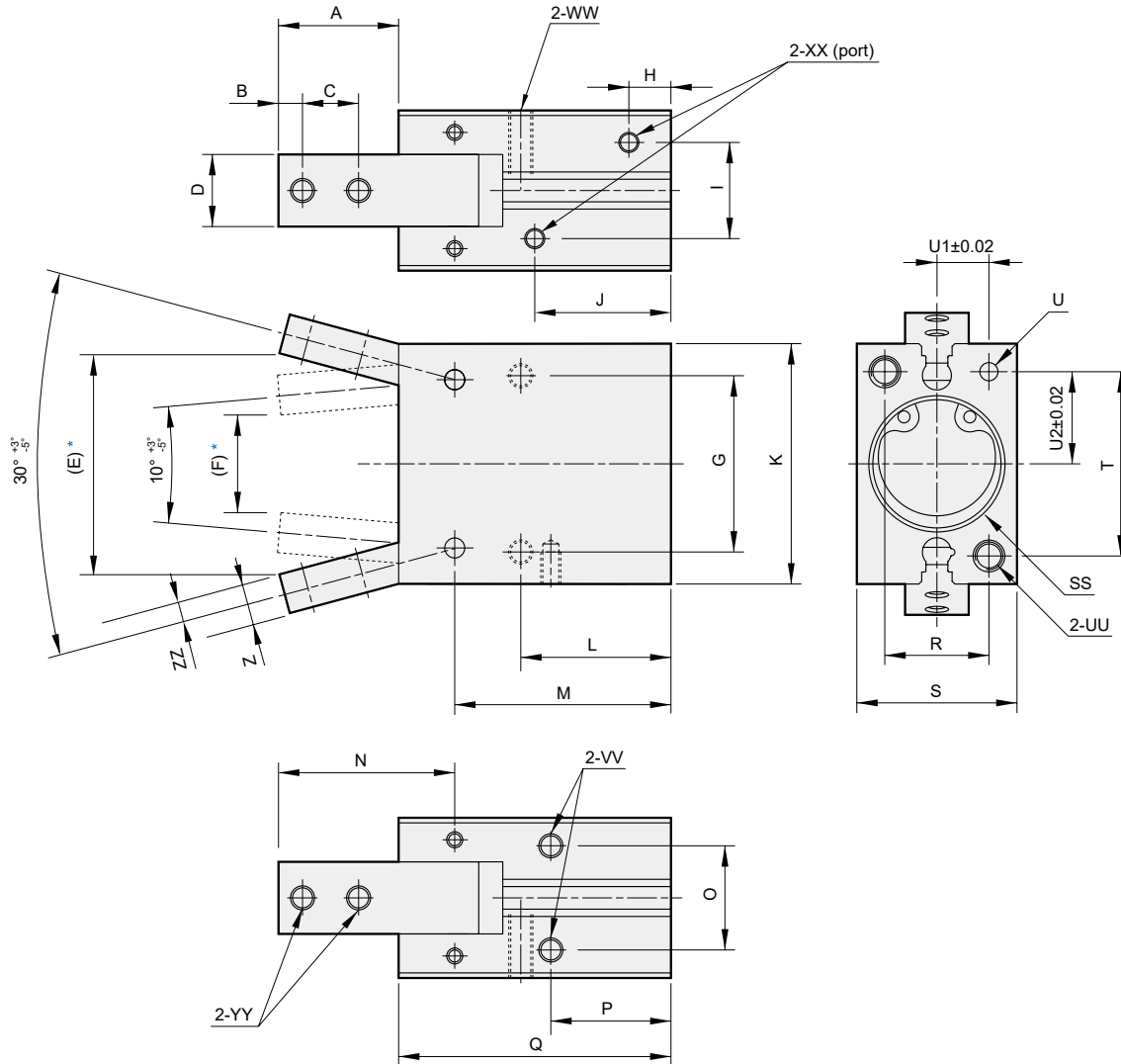

\* Reference value.

Code Tube I.D.	A	B	C	D	E	F	G	H	I	J	K	L	M	N	O	P	Q	R	S	SS	T
12	15.4	3	6	7	26.3	11.3	20	7.5	10.2	23	28	20	32.9	21.5	10.2	16	39	10	16	$\varnothing 14H9^{+0.043}_0 \times 1.5$ depth	22
16	17.5	3	8	9	31.1	13.7	24	7.5	12	22	34	22.5	35	25	14	18	42.5	14	22	$\varnothing 18H9^{+0.043}_0 \times 1.5$ depth	26
20	22	4	10	12	40	17.3	30	8.0	13	25	45	25	39.5	32.5	16	19	50	16	26	$\varnothing 22H9^{+0.052}_0 \times 1.5$ depth	35
25	25.5	5	12	14	47.9	21.4	36	8.5	18	28	52	28.5	45.5	38	20	21.5	58	20	32	$\varnothing 27H9^{+0.052}_0 \times 2$ depth	40
32	30	6	14	18	55.1	24.4	44	10.5	24	34	60	37.5	54	44	26	30	68	26	40	$\varnothing 34H9^{+0.062}_0 \times 2.5$ depth	46

Code Tube I.D.	U	U1	U2	UU	VV	WW	XX	YY	Z	ZZ
12	$\varnothing 2H9^{+0.025}_0 \times 3$ depth	5	11	M3×0.5×5 depth	M3×0.5×5 depth	M3×0.5×8 depth	M3×0.5×5 depth	M3×0.5	5	2.5
16	$\varnothing 3H9^{+0.025}_0 \times 3$ depth	7	13	M4×0.7×7 depth	M4×0.7×7 depth	M4×0.7×11 depth	M5×0.8×5 depth	M3×0.5	6	3
20	$\varnothing 4H9^{+0.03}_0 \times 4$ depth	8	17.5	M5×0.8×8 depth	M5×0.8×8 depth	M5×0.8×12 depth	M5×0.8×5 depth	M4×0.7	7	3.5
25	$\varnothing 4H9^{+0.03}_0 \times 4$ depth	10	20	M6×1.0×10 depth	M6×1.0×8 depth	M6×1.0×16 depth	M5×0.8×5 depth	M5×0.8	9	4
32	$\varnothing 5H9^{+0.03}_0 \times 5$ depth	13	23	M6×1.0×10 depth	M6×1.0×8 depth	M6×1.0×20 depth	M5×0.8×5 depth	M6×1.0	10	5