



# S201 – G4/G5 (AC)

-- Service and Installation --

10/27/2023 Rev.1

## DESCRIPTION

The S201 Series Solenoid Valves are 2-way, normally closed, piloted, zero differential general-purpose valves. All Stainless Steel, Brass, or Nylon construction with synthetic seating and sealing materials make them suitable for use with a variety of liquids, oils, and gases. Valves may be mounted in any position. A spring-loaded plunger assures positive shutoff. The S4 solenoid coil is rated at 10 watts.

## OPERATION

S201 Valves are normally closed (N.C.) and open when electrically energized.

## SPECIFICATIONS

Use S201 Valves within the specified operating ranges as indicated on the nameplate and in the complete Catalog Number. (min./max. psi, voltage, hz, maximum media temperature at F ambient, Cv factor, etc.).

### OPERATING TEMPERATURES

Ambient	Elastomer	Fluid
32° - 125° F	EPR	32° - 295° F
32° - 125° F	Nitrile	32° - 180° F
32° - 125° F	FKM	32° - 230° F

### NYLON OPERATING TEMPERATURES

Ambient	Elastomer	Fluid
32° - 125° F	EPR	32° - 180° F
32° - 125° F	Nitrile	32° - 180° F
32° - 125° F	FKM	32° - 180° F

For other applications, consult the factory.

## INSTALLATION

Check valve specifications to make sure of proper application.

1. Clear all lines of foreign matter.
2. Valves are multipositioned and may be mounted in any position. Media flow must be in the direction indicated on the valve body. If sediment is a problem, install a fine mesh strainer having adequate capacity ahead of the valve.
3. Do not use the solenoid housing as a handle. Apply thread seal to the male threads only.
4. Provide clearance for solenoid removal.
5. Wire in accordance with applicable local and national electrical codes. Apply rated voltage.

## MAINTENANCE

### COIL REPLACEMENT

**Turn off the electrical power supply to the solenoid before disconnecting the coil lead wires.**

Incorrect coil reassembly can cause coil burnout. At all times, take care not to nick, dent, or damage the plunger tube.

It is not necessary to remove the valve from the pipeline. Follow Steps 1, 2, and 3 under **VALVE DISASSEMBLY**. Disassemble the solenoid, taking care to note the exact order of placement and quantity of parts.

Incorrect reassembly can cause coil burnout. At all times, take care not to nick, dent, or damage the plunger tube.

## PARTS

The charts that follow cover replaceable coil part numbers and Repair/Rebuild kits for most S201 valves.

When ordering parts/kits, specify the Catalog Number, Serial Number, and Part Name. If your valve's Catalog Number is not listed, obtain the complete Serial Number, and consult the factory.

## REBUILD KIT

The Rebuild Kit contains a plunger/spring/seat disc assembly, plunger tube assembly, O-rings, and an adapter ring.

## REPAIR KIT

The Repair Kit contains a seat disc, diaphragm assembly, and O-rings.

### REBUILD & REPAIR KIT CHART

Valve	Rebuild Kits	Repair Kits
S201GF__C__G4	KS201C-G4	R201C-G4
S201GF__C__G5	KS201C-G5	R201C-G5
S201GF__N__G4	KS201N-G4	R201N-G4
S201GF__N__G5	KS201N-G5	R201N-G5
S201GF__V__G4	KS201V-G4	R201V-G4
S201GF__V__G5	KS201V-G5	R201V-G5
S201GF__E__G4	KS201E-G4	R201E-G4
S201GF__E__G5	KS201E-G5	R201E-G5
S201GF__J__G4	KS201J-G4	R201J-G4
S201GF__J__G5	KS201J-G5	R201J-G5
S201GF__L__G4	KS201L-G4	R201L-G4
S201GF__L__G5	KS201L-G5	R201L-G5

### COIL CHART

Valve	Voltage	DIN Coil	Conduit Coil
S201GF02__	120V 50/60	HS4YN02	HS4GN02A24
S201GF03__	208V 50/60	HS4YN03	HS4GN03A24
S201GF04__	240V 50/60	HS4YN04	HS4GN04A24
S201GF24__	24V 50/60	HS4YN24	HS4GN24A24

## Cleaning

**Cleaning fluid must be compatible with all valve components.** It is recommended that S201 Series Valves be cleaned on a routine basis by qualified personnel. Valves should be cleaned where flow media or service conditions may determine the life of the valve. If excessive leakage occurs or if the operation is sluggish, the unit must be cleaned.

## SERVICE DISASSEMBLY AND KIT INSTALLATION

### WARNING

Disassembly, reassembly, or internal adjustment without factory testing may result in hazardous conditions. If the valve does not operate properly after following the INSTALLATION and MAINTENANCE instructions, the complete valve must be replaced by a trained and experienced service person.

1. Disconnect electrical connections and remove retaining nut (1). Remove with lock washer (2).
2. Lift off coil (3) from the plunger tube.
3. Do not damage the solenoid assembly.
4. Use a 1" deep socket to remove plunger tube (4). Do not nick, dent, or damage the plunger tube (4) or valve seating surfaces.
5. Carefully hold plunger tube (4) in position when removing from valve bonnet (10) to prevent loss of internal parts.
6. Remove return spring (6) plunger assembly (7),
7. Remove four bonnet bolts (9) and separate valve bonnet (10) from valve body (13).
8. Carefully remove the connecting spring (8) from the diaphragm (11) and plunger (7) assemblies.
9. Check plunger seat disc (7) and diaphragm assembly (11) for damage or wear.
10. Replace O-rings (5 & 12), diaphragm assembly (11), plunger seat disc (7), and other parts as necessary. Consult the "REBUILD & REPAIR KIT CHART" for the correct kit part number.
11. Re-assemble in reverse order from above, taking care to properly re-install the plunger seat disc (7) and connecting spring (8).
12. Brass/SS Valve- Tighten plunger tube (4) to 50 in/lbs. and bonnet bolts (9) to 75 in/lbs. Nylon Valves - Tighten plunger tube (4) to 30 in/lbs. and bonnet bolts (9) to 20 in/lbs
13. Re-connect electrical and test for proper operation.

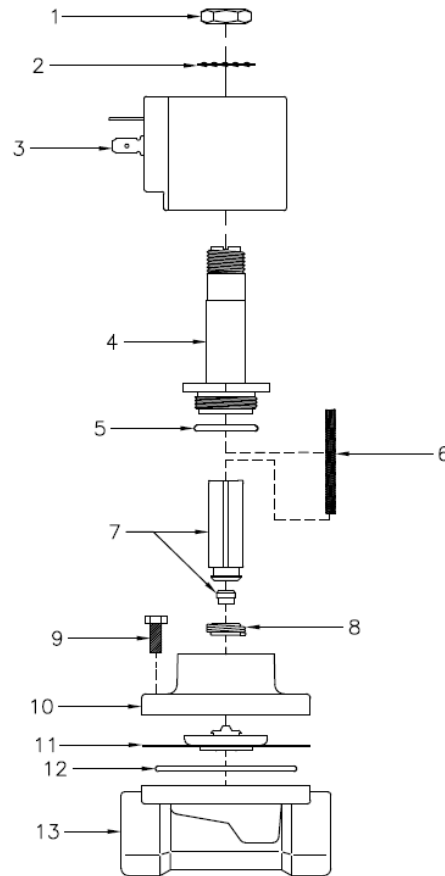

**Special Note – Older units may require a GCV Spanner Nut Tool (106198E) or spanner wrench to remove the plunger tube base nut. Consult your distributor or call GCV customer service for assistance.**

### TROUBLESHOOTING

If the valve fails to open, check the voltage against the rating on the nameplate, check the voltage at solenoid lead connections, and check the control circuit and solenoid coil for burnout. If the valve fails to close, check the condition of the synthetic seat insert. Also, check for a damaged spring. The valve must be free of dirt to ensure tight shutoff. If media contaminants are a problem, install a fine mesh strainer to ensure proper closing and trouble-free operation.

Buzzing can be caused by low voltage or contaminants between the top of the plunger and the tube head. Check voltage--clean the plunger/interior of the tube assembly.

GC Valves, LLC. 456 Crompton St., Charlotte, NC 28241

Ph: 704-588-3300, Fx: 704-973-9526, [Service@gcvalves.com](mailto:Service@gcvalves.com)