



250W to 400W Touch-Safe PTC Fan Heaters with Integral Thermostat



Panel Mount Fan Heater



DIN Mount Fan Heater

Applications

These touch-safe positive temperature coefficient fan heaters prevent the formation of condensation and provide evenly distributed interior air temperature in enclosures. The touch-safe plastic housing and the small size make these heaters ideal for use in enclosures with a high packing density. Each heater is equipped with a fixed set point thermostat and is easily wired via external pressure clamps. DIN rail or screw tab mounting options are available. The robust panel mounting is particularly suitable for applications with high vibration.

Features

- Compact fan heater
- Integrated pre-set thermostat
- Quiet operation
- Heating power adjusts to ambient temperature
- DIN rail or panel mount available



250W to 400W Touch-Safe PTC Fan Heaters with Integral Thermostat Specifications		
	DIN Mount	Panel Mount
Heating Element	PTC Resistor - Temperature limiting	
Surface Temperature	250W: max. 122°F [50°C] 400W: max. 149°F [65°C] Each except upper protective grill at 68°F [20°C] ambient temperature	
Overheat Protection	Built-in temperature limiter	
Axial Fan, Ball Bearing	Service life 40,000h at 104°F [40°C]	
Axial Fan, Free Blowing	32 cfm [54 m³/h] @ 120V AC; 26 cfm [45 m³/h] @ 230V AC	
Connection	2-pole dual pressure clamp 14 AWG [2.5 mm²], max. solid wire 16 AWG [1.5 mm²] max. stranded wire with wire end ferrule	
Housing	Plastic, UL 94V-0, black	
Mounting	Clip for 35mm DIN rail, EN 60715	Screw mount - M5 screws & washer (not included)
Mounting Position	Vertical airflow (air outlet up), horizontal airflow	
Operating / Storage Temperature	-40 to 158°F [-40 to 70°C] -49 to 158°F [-45 to 70°C]	
Recommended Mounting Distance	Sides: 0.79 in [20mm] Bottom/above: 3.94 in [100mm]	
Operating / Storage Humidity	Max. 90% RH (non-condensing)	
Protection Class	II (double insulated)	
Protection Type	IP20	
Approvals	CE, UL Recognized File No. E150057, RoHS 2 compliant	

To obtain the most current agency approval information, see the Agency Approval Checklist section on the specific part number's web page at www.AutomationDirect.com

250W to 400W Touch-Safe PTC Fan Heaters with Integral Thermostat									
Part Number	Price	Part Number	Price	Heating Capacity ¹	Operating Voltage	Max. current (inrush)	Switch-off Temp ²	Switch-on Temp ²	Weight (approx.)
DIN Mount		Panel Mount							
028219-06	\$111.00	028219-08	\$111.00	250W	120V AC, 50/60 Hz	6.0 A	59°F [15°C]	41°F [5°C]	17.6 oz [499g]
028210-06	\$111.00	028210-08	\$111.00		230V AC, 50/60 Hz	9.0 A			
028209-06	\$121.00	028209-08	\$121.00	400W	120V AC, 50/60 Hz	9.0 A	59°F [15°C]	41°F [5°C]	
028200-06	\$121.00	028200-08	\$121.00		230V AC, 50/60 Hz	15.0 A			

¹ At 68°F [20°C] ambient temperature @ 60Hz
² Tolerance of ±9°F [±5 K]



250W to 400W Touch-Safe PTC Fan Heaters with Integral Thermostat

Dimensions:

DIN Rail Mount Inches [mm]

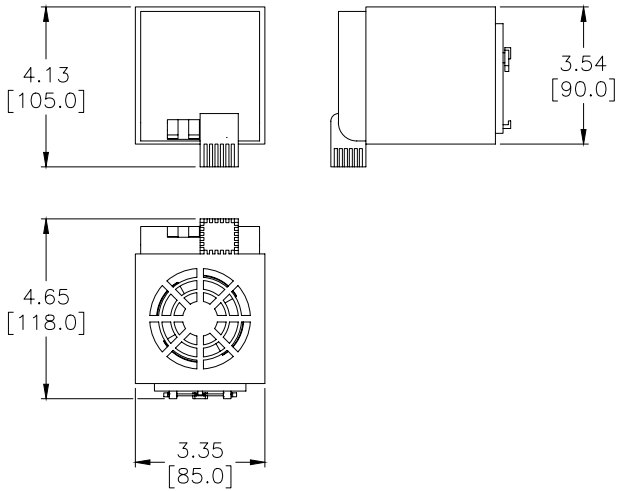

Panel Mount Inches [mm]

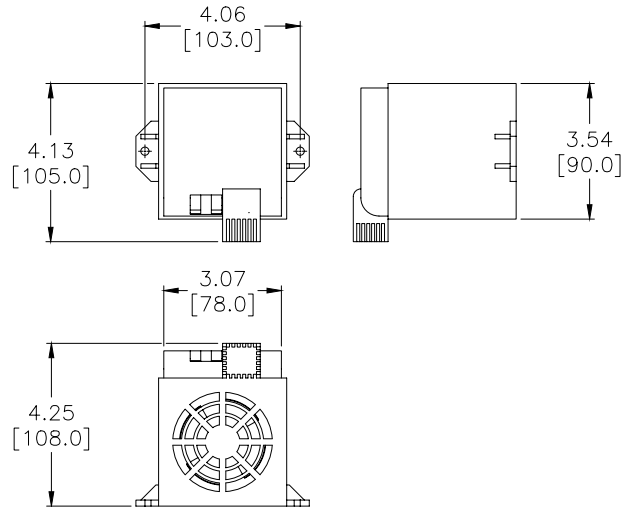

Please see our website www.AutomationDirect.com for complete engineering drawings.

Wiring Diagram

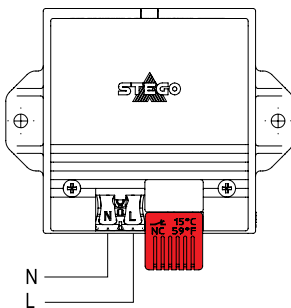

Note: When wiring 230 volt units for North American installations "L" (line) and "N" (neutral) will be used as "L1" (line1) "L2" (line2) respectively with no neutral connection.

Enclosure Heating and Heater Selection

Why Heat an Enclosure?

Today's miniaturization of enclosure components results in high packing densities, which in turn results in higher temperatures within the enclosure. These high temperatures are harmful to electronic components. In response, cooling systems have become standard in many applications. However, just as critical and widely underestimated, are failures caused by the formation of moisture.

Under certain climatic conditions, moisture can build up not only in outdoor or poorly insulated enclosures, but also in highly protected and well-sealed enclosures.

Moisture and Failure

Moisture, especially when combined with aggressive gases and dust, causes atmospheric corrosion and can result in the failure of components such as circuit breakers, busbars, relays, integrated circuit boards and transformers. The greatest danger lies in conditions where electronic equipment is exposed to relatively high air humidity or extreme variations in temperature, such as day-and-night operation or outdoor installation. Failure of components in such cases is usually caused by changing contact resistances, flashovers, creepage currents or reduced insulation properties.

Eliminate Moisture

Moisture and corrosion will remain low if relative air humidity stays below 60%. However, relative humidity above 65% will significantly increase moisture and corrosion problems. This can be prevented by keeping the environment inside an enclosure at a temperature as little as 9°F (5°C) higher than that of the ambient air. Constant temperatures are a necessity to guarantee optimal operating conditions. Continuous temperature changes not only create condensation but they reduce the life expectancy of electronic components significantly. Electronic components can be protected by cooling during the day and heating at night.

Thermal Management

Modern enclosure heaters are designed to protect against condensation. They heat the air inside enclosures, preventing water vapor from condensing on components while providing the greatest possible air circulation and low energy consumption.

Other heating element technology improvements include:

- Longer operating life
- Greater energy efficiencies
- Quick wiring options
- Easier mounting
- Fan heaters should be considered for larger enclosures to ensure that the entire enclosure is heated uniformly

Heater Location

Ideally, most heaters will perform optimally when mounted near the bottom of an enclosure and used in conjunction with a control device, thermostat, and/or hygrostat. The control device may be a separate device, or it may be integral to the heater. With the controller located in an area of the cabinet that is representative of the average temperature or humidity

requirement, the heater should then be placed in a position near the bottom of the enclosure. If a separate control device is used, the heater should not be located directly beneath the controller to ensure that the controller is not influenced by direct heat from the heater.

Heater Calculation

Follow Steps 1-5 to determine the heating requirement of an enclosure (US units - left column, metric - right)

STEP 1: Determine the Surface Area (A) of your enclosure which is exposed to open air.

Enclosure Dimensions:

height = _____ feet _____ meters

width = _____ feet _____ meters

depth = _____ feet _____ meters

Choose Mounting Option from next page, and calculate the surface area as indicated

$$A = \text{_____ ft}^2 \text{ or } \text{_____ m}^2$$

STEP 2: Choose the Heat Transmission Coefficient (k) for your enclosure's material of construction.

painted steel = 0.511 W/(ft²•K) 5.5 W/(m²•K)

stainless steel = 0.344 W/(ft²•K) 3.7 W/(m²•K)

aluminum = 1.115 W/(ft²•K) 12 W/(m²•K)

plastic or insulated

stainless = 0.325 W/(ft²•K) 3.5 W/(m²•K)

$$k = \text{_____ W/(ft}^2\text{•K)} \text{ or } \text{_____ W/(m}^2\text{•K)}$$

STEP 3: Determine the Temperature Differential (ΔT).

A. Desired enclosure interior temp. = _____ °F _____ °C

B. Lowest ambient (outside) temp. = _____ °F _____ °C

Subtract B from A = Temp. diff. (ΔT) = _____ °F _____ °C

For these calculations, ΔT must be in degrees Kelvin (K). Therefore, divide ΔT (°F) by 1.8. ΔT = _____ K

STEP 4: Determine Heating Power (P_V), if any (generated from existing components, i.e. transformer).

$$P_V = \text{_____ W} \text{ or } \text{_____ W}$$

STEP 5: Calculate the Required Heating Power (P_H) for your enclosure based on the above values.

If enclosure is located inside:

$$P_H = (A \times k \times \Delta T) - P_V = \text{_____ W}$$

If enclosure is located outside:

$$P_H = 2 \times (A \times k \times \Delta T) - P_V = \text{_____ W}$$

Enclosure Mounting Types and Surface Area Calculations

1. Free-Standing

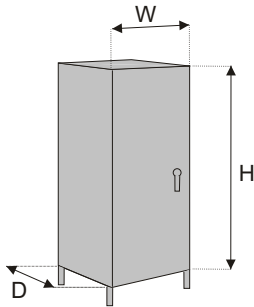

$$\text{Area (A)} = 1.8 (H \times W) + 1.8 (H \times D) + 1.8 (W \times D)$$

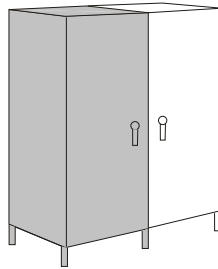

$$\text{Area (A)} = 1.8 (H \times W) + 1.4 (H \times D) + 1.8 (W \times D)$$

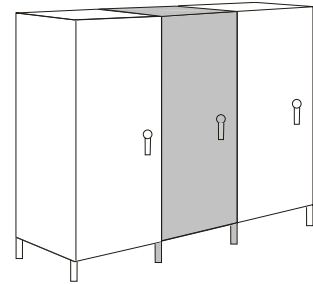

$$\text{Area (A)} = 1.8 (H \times W) + (H \times D) + 1.8 (W \times D)$$

2. Wall-Mounted

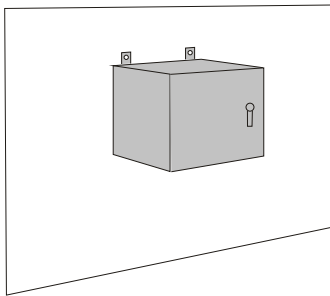

$$\text{Area (A)} = 1.4 (H \times W) + 1.8 (H \times D) + 1.8 (W \times D)$$

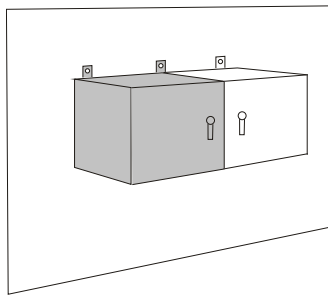

$$\text{Area (A)} = 1.4 (H \times W) + 1.4 (H \times D) + 1.8 (W \times D)$$

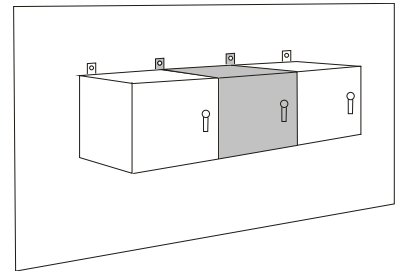

$$\text{Area (A)} = 1.4 (H \times W) + (H \times D) + 1.8 (W \times D)$$

3. Ground

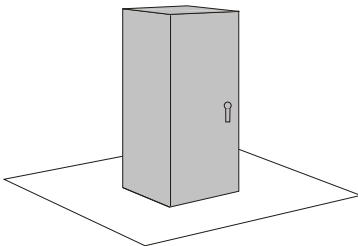

$$\text{Area (A)} = 1.8 (H \times W) + 1.8 (H \times D) + 1.4 (W \times D)$$

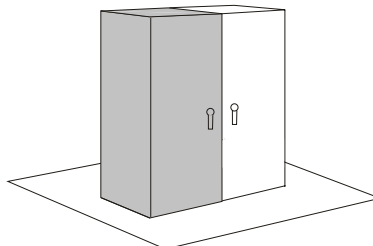

$$\text{Area (A)} = 1.8 (H \times W) + 1.4 (H \times D) + 1.4 (W \times D)$$

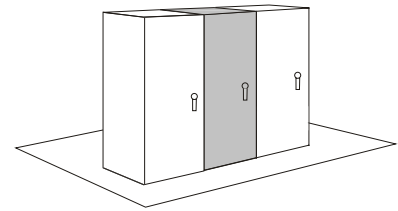

$$\text{Area (A)} = 1.8 (H \times W) + (H \times D) + 1.4 (W \times D)$$

4. Ground and Wall

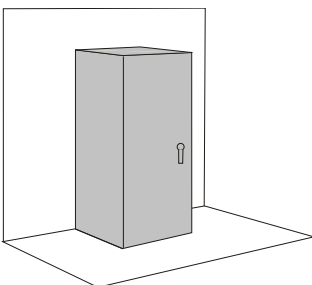

$$\text{Area (A)} = 1.4 (H \times W) + 1.8 (H \times D) + 1.4 (W \times D)$$

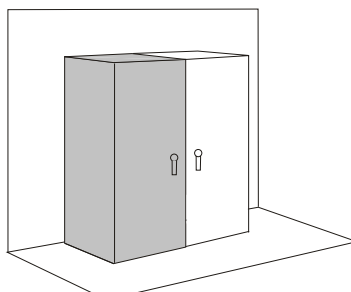

$$\text{Area (A)} = 1.4 (H \times W) + 1.4 (H \times D) + 1.4 (W \times D)$$

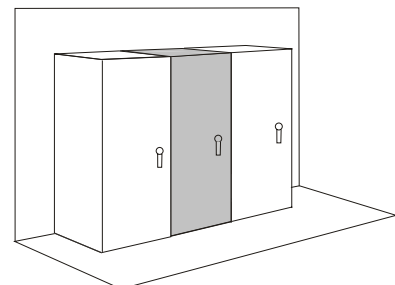

$$\text{Area (A)} = 1.4 (H \times W) + (H \times D) + 1.4 (W \times D)$$