



Filter Fan Plus

Air Flap Design

The Stego Filter Fan Plus series employs a new air flap design for the air outlet. The air flaps have less resistance to airflow than an exhaust filter, which allows the Filter Fan Plus system to achieve higher airflow while still preventing the ingress of contaminants. Curved air flaps react to small airflow volumes for maximum opening of flaps. Filter Fan Plus series fans are for indoor use only.



Ratchet Mounting

A ratchet mechanism is used for mounting, providing a high stability and tightness. No mounting screws needed. Prevents enclosure wall deformity when mounting. Solid locking ensures uniform seal.

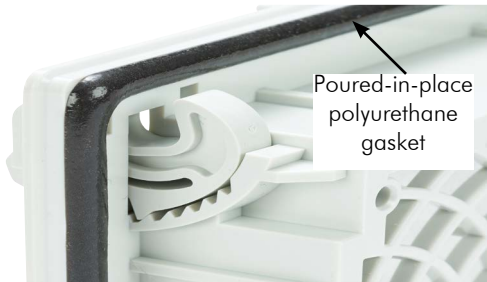

A common 3 to 3.5 mm screwdriver is used to release the ratchet mechanism.

Filter Fan Plus Models: FPI or FPO

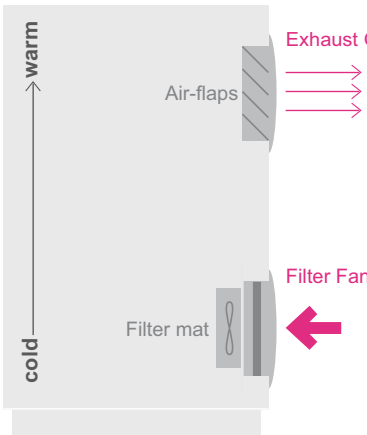

FPI systems (airflow direction 'in') use a filter fan in the lower part of the enclosure, ensuring fresh air is fed into the enclosure. The air rises to the top of the enclosure, cooling the internal space and pushing the warm interior air through the exhaust grille near the top. This grille exhausts hot air more effectively, thanks to new air flap outlet technology.

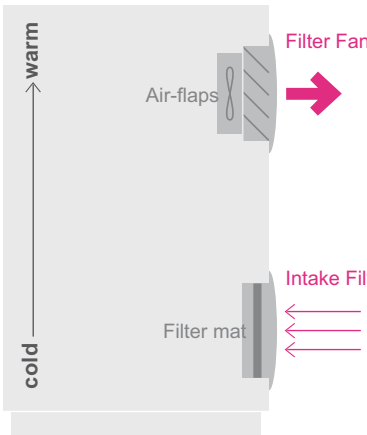

In FPO systems (airflow direction 'out'), the filter fan is located in the upper area of the enclosure to avoid heat buildups. The heat can be diverted quicker from the critical area. An intake grille with a filter in the lower part of the enclosure allows the colder air from the outside to enter.



Filter Fan Plus



Features

- FPI (airflow in) or FPO (airflow out) models
- Air flap outlet technology
- IP54 dust and splash waterproof
- Easy filter change with access provided via the hinged cover
- Impact resistant
- UV light resistant according to UL 746C (f1)
- Flame retardant: UL94 V-0
- Low noise
- 115 and 230VAC models available
- 12, 24, and 48VDC models available
- (4) 6-position ratchet lever mount mechanism will accommodate wall thickness 0.039 - 0.157in (1 - 4mm)

Construction

- Fan body is light gray plastic polycarbonate
- FPI model has an intake filter fan and an exit grille with air flaps
- FPO model has an exit fan with air flaps and an intake grille with filter
- Poured-in-place polyurethane gasket for better seal
- Mounts using built-in ratchet mechanism; no screws needed. (Hardware provided for optional screw mounting. Hole markings for screw mounting are indicated on mounting frame.)

Applications

Filter fans provide an optimum climate in enclosures with electrical/electronic components. The interior temperature of enclosures is reduced by channeling cooler filtered outside air into the enclosure, thus expelling heated internal air. The resulting air flow prevents formation of localized heat pockets and protects electronic components from overheating.

Standards

- All models: IP54, VDE, EAC, CE, UL Type 12 when using supplied filter.
- UL Recognized - file: E234324

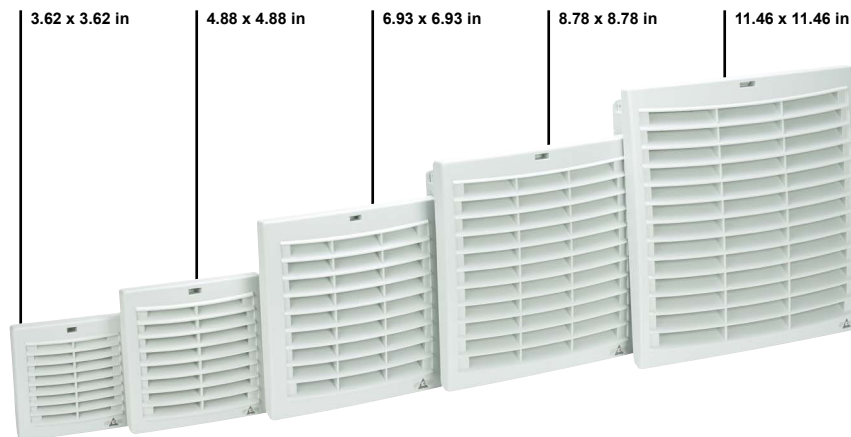

STEGO Filter Fan Plus

INC.
SIMPLY INNOVATIVE. BETTER FOR SURE.



018740-30



118740-00

11.46 x 11.46 inch Cutout Size

- Storage temperature: -40 to 158°F (-40 to 70°C)
- Operating temperature: -13 to 95°F (-25 to 35°C)
- Connection type: 3-pole clamp for AWG 14 (2.5 mm²), clamping torque 7.1 lb-in (0.8 N-m) max
- Service life: 76,000 hrs @ 104°F (40°C)
- Average arrestance: 84% with provided G3 (coarse) filter
- Replacement filter mats
G3 (coarse): 086370-00
G4 (medium): 086290-00
M5 (fine): 086320-00

Filter Fan Plus - FPI System										
Part Number	Price	Description	Filter/ Air Flaps	Operating Voltage	Power Consumption (W)	Current Draw (mA)	Free Airflow (CFM)	Airflow with Grille & Filters (CFM)	Max Static Pressure (Pa)	Sound Level (dB)
018740-30	\$195.00	Enclosure fan	G3 filter	230VAC	95	413	255	220	99	62
018749-30	\$212.00	Enclosure fan	G3 filter	115VAC	90	783	232	200	73	61
118740-00	\$62.50	Exhaust grille	Air flaps	FPI exhaust grille designed to be used with the FPI fans listed above only.						

Note: Performance data (current draw, power consumption, free airflow with a grille and filters, sound level) for all AC fans is based on 60Hz.



018840-00



118840-30



Filter Fan Plus - FPO System										
Part Number	Price	Description	Filter/ Air Flaps	Operating Voltage	Power Consumption (W)	Current Draw (mA)	Free Airflow (CFM)	Airflow with Grille & Filters (CFM)	Max Static Pressure (Pa)	Sound Level (dB)
018840-00	\$206.00	Enclosure fan	Air flaps	230VAC	95	413	428	243	107	63
018840-40	\$195.00	Enclosure fan	G3 filter	230VAC	95	413	265	187	99	63
018849-00	\$223.00	Enclosure fan	Air flaps	115VAC	90	783	414	230	80	62
018849-40	\$212.00	Enclosure fan	G3 filter	115VAC	90	783	256	177	73	62
118840-30	\$48.50	Intake grille	G3 filter	FPO intake grille designed to be used with the FPO fans listed above only.						

Note: Performance data (current draw, power consumption, free airflow with a grille and filters, sound level) for all AC fans is based on 60Hz.



Filter Fan Plus - Dimensions

Dimensions

inches [mm]

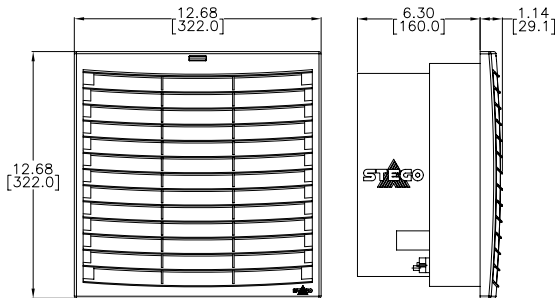

**11.46 x 11.46 in Cutout Size
FPI Fan**

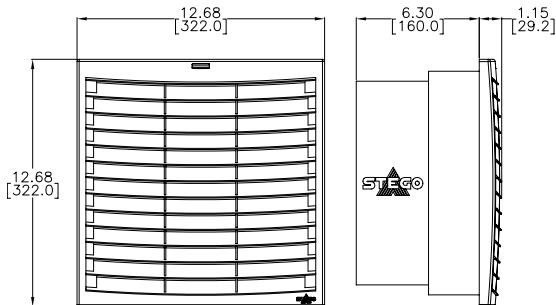

**11.46 x 11.46 in Cutout Size
FPO Fan**

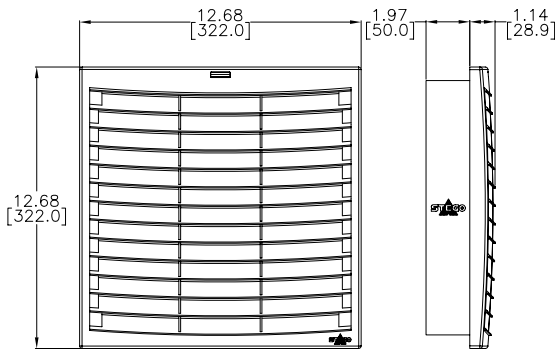

**Exhaust grille for
11.46 x 11.46 in
FPI Fan**

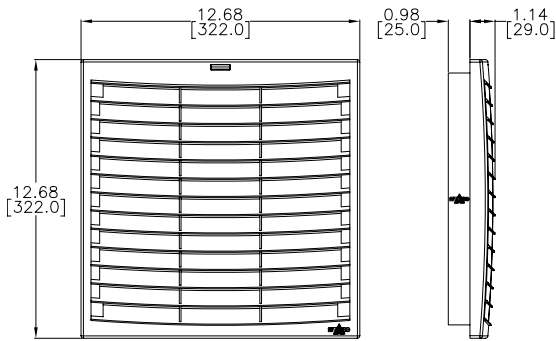

**Intake grille for
11.46 x 11.46 in
FPO Fan**

See our website: www.AutomationDirect.com for complete engineering drawings



Filter Fan Replacement Filter Mats

086000-00



Filter Mats

- Synthetic fiber with progressive construction
- Temperature resistant to 212 °F (100°C)
- Rating: G3 (coarse), G4 (medium), and G5 (fine)
- Self-extinguishing class F1
- Moisture resistant to 100% RH
- Reusable; can be cleaned with mild soap or vacuuming

Features

- Filter media for enclosure fans
- Fine or medium density
- Fits 3.82 x 3.82, 4.92 x 4.92, 6.93 x 6.93, or 9.84 x 9.84, inch Filter Fan
- Fits 3.62 x 3.62, 4.88 x 4.88, 6.93 x 6.93, 8.78 x 8.78, and 11.46 x 11.46 inch Filter Fan Plus

Applications

- Replacement filter mats for Stego series Filter Fan Plus, Filter Fan, and Stego series exhaust/intake grilles

Replacement Filter Elements									
Part Number	Price	Dimensions HxW in (mm)	Use With Filter Fan Part Number	Use With Intake or Exhaust Grille Part Number	Filter Rating	Average Arrestance (Filtering Level)	Filter Density g/m2	Pieces per Package	
086330-00	\$7.50	3.31 x 3.31 [84 x 84]	018700-30	118800-30					
			018701-30						
			018702-30						
			018703-30						
			018709-30						
			018800-40						
086340-00	\$10.00	4.65 x 4.65 [118 x 118]	018010-01	118010-00 118210-00 118810-30					
			018010-02						
			018210-02						
			018210-04						
			018710-30						
			018711-30						
			018712-30						
			018713-30						
			018719-30						
			018810-40						
086350-00	\$13.25	6.61 x 6.61 [168 x 168]	018020-01	118020-00 118820-30		G3 (coarse)	84%	200	5
			018020-02						
			018040-01						
			018720-30						
			018721-30						
			018722-30						
			018723-30						
			018729-30						
			018820-40						
			018829-40						
086360-00	\$17.25	8.46 x 8.46 [215 x 215]	018730-30	118830-30					
			018739-30						
			018830-40						
086370-00	\$22.50	11.14 x 11.14 [283 x 283]	018740-30	118840-30					
			018749-30						
			018840-40						
			018849-40						

Table continued on next page



Replacement Filter Elements

Replacement Filter Elements (continued)								
Part Number	Price	Dimensions HxW in (mm)	Use With Filter Fan Part Number	Use With Intake or Exhaust Grille Part Number	Filter Rating	Average Arrestance (Filtering Level)	Filter Density g/m2	Pieces per Package
086270-00	\$6.25	3.31 x 3.31 [84 x 84]	018700-30, 018701-30 018702-30, 018703-30 018709-30, 018800-40 018809-40	118800-30	G4 (medium)	94%	350	3
086000-00	\$5.00	3.50 x 3.50 [89 x 89]	018000-01, 018000-02	118000-00				
086010-00	\$6.00	4.65 x 4.65 [118 x 118]	018010-01, 018010-02 018210-02, 018210-04 018710-30, 018711-30 018712-30, 018713-30 018719-30, 018810-40 018819-40	118010-00 118210-00 118810-30				
086020-00	\$8.00	6.61 x 6.61 [168 x 168]	018020-01, 018020-02 018040-01, 018720-30 018721-30, 018722-30 018723-30, 018729-30 018820-40, 018829-40	118020-00 118820-30				
086280-00	\$11.75	8.46 x 8.46 [215 x 215]	018730-30, 018739-30 018830-40, 018839-40	118830-30				
086080-00	\$20.00	9.72 x 9.72 [247 x 247]	018030-01, 018030-03 018050-01	118030-00				
086290-00	\$16.00	11.14 x 11.14 [283 x 283]	018740-30, 018749-30 018840-40, 018849-40	118840-30				
086300-00	\$6.25	3.31 x 3.31 [84 x 84]	018700-30, 018701-30 018702-30, 018703-30 018709-30, 018800-40 018809-40	118800-30	M5 (fine)	98%	360	3
086030-00	\$6.00	3.50 x 3.50 [89 x 89]	018000-01, 018000-02	118000-00				
086040-00	\$7.50	4.65 x 4.65 [118 x 118]	018010-01, 018010-02 018210-02, 018210-04 018710-30, 018711-30 018712-30, 018713-30 018719-30, 018810-40 018819-40	118010-00 118210-00 118810-30				
086050-00	\$12.00	6.61 x 6.61 [168 x 168]	018020-01, 018020-02 018040-01, 018720-30 018721-30, 018722-30 018723-30, 018729-30 018820-40, 018829-40	118020-00 118820-30				
086310-00	\$11.75	8.46 x 8.46 [215 x 215]	018730-30, 018739-03 018830-40, 018839-40	118830-30				
086090-00	\$24.00	9.72 x 9.72 [247 x 247mm]	018030-01, 018030-30 018050-01	118030-00				
086320-00	\$16.00	11.14 x 11.14 [283 x 283]	018740-30, 018749-30 018840-40, 018849-40	118840-30				



Air Volume and Pressure Data for Upgraded Filter Mats

Airflow and Pressure Data						
Fan Part Number	Filter Mat Airflow (cfm)				Filter Mat Static Pressure (Pa)	
	G4 fan filter*	G4 fan filter and exhaust filter**	M5 fan filter free flow*	M5 fan filter with exhaust filter**	G4 fan filter free flow*	M5 fan filter*
018000-02	–	9	4	3	–	37
018000-01	–	11	5	4	–	35
018010-02	–	25	16	13	–	53
018010-01	–	28	19	15	–	50
018020-02	–	40	31	21	–	30
018020-01	–	46	36	24	–	35
018040-01	–	84	58	36	–	100
018030-03	–	135	47	36	–	46
018030-01	–	156	54	42	–	54
018050-01	–	203	145	83	–	140
018700-30	9.4	7.1	4.1	3.5	48	48
018800-00	14	7.7	14	4.1	48	48
018800-40	11	7.7	11	4.7	48	48
018710-30	28	25	14	12	76	76
018810-00	57	26	57	12	76	76
018810-40	33	24	33	12	76	76
018720-30	83	74	48	41	140	140
018820-00	155	74	155	40	140	140
018820-40	106	66	106	38	140	140
018730-30	147	130	70	62	132	132
018830-00	316	140	316	74	136	136
018830-40	183	121	183	68	132	132
018740-30	250	212	118	94	107	107
018840-00	428	218	428	109	117	117
018840-40	300	153	300	100	107	107

Notes: *Fan with filter and louver
**Fan with filter, louver, exhaust filter, and grille.
Part numbers not listed in this table have no test data available.

Enclosure Cooling – Selecting a Fan or Air Conditioner

Fan selection

To select the proper size (CFM) fan for your forced air cooling solution, you need to determine the amount of heat to be removed (in watts) and determine the Delta T (Max. allowable internal enclosure temperature °F – Max. outside ambient temperature °F).

CFM = Cubic Feet per Minute

P = Power to be dissipated in watts

CFM = (3.17 x P_{watts}) / Delta T °F

Delta T = max. allowable internal enclosure temperature °F – max. outside ambient temperature °F

Stego offers an online [Cooling Calculation Tool](#) to help you calculate the required airflow rate for your application.

Air conditioner and vortex cooler selection

To select the proper size air conditioner or vortex cooler, the worst-case conditions should be considered, but take care not to choose an oversized unit.

There are two main factors in choosing an uninsulated metal NEMA rated enclosure located indoors:

- Internal heat load
- Heat load transfer

Internal Heat Load

Internal heat load is the heat generated by the components inside the enclosure. This can be determined by a few different methods. The preferred method is to add the maximum heat output specifications that the manufacturers list for all the equipment installed in the cabinet. This is typically given in Watts, so use the following conversion:

BTU per Hour = Watts x 3.413

Example: The Watt-loss chart for the GS3 Drives shows that a GS3-2020 AC drive has a Watt-loss of 750 watts.

BTU per Hour = 750 watts x 3.413

BTU per Hour = 2559

Heat Load Transfer

Heat load transfer is the heat lost (negative heat load transfer) or gained (positive heat load transfer) through the enclosure walls with the surrounding ambient air. This can be calculated by the following formula:

Heat load transfer (BTU/H) = 1.25 x surface area (sq. ft.) x (max. outside ambient air (°F) – max. allowable internal enclosure temperature air (°F))

Surface Area (sq. ft.) = 2 [(H x W) + (H x D) + (W x D)] / 144 sq. inches

Note: 1.25 is an industry standard constant for metal enclosures; 0.62 should be used for plastic enclosures.

Once you have determined your Internal Heat Load and the Heat Load Transfer, you can choose the proper size unit by calculating the needed cooling capacity.

Cooling capacity (BTU/H) = Internal Heat Load ± Heat Load Transfer

Fan Selection Example

A NEMA 12 Hubbell Wiegmann N12302412 enclosure (30" high x 24" wide x 12" deep) contains a GS3-2020 AC drive (20 HP 230 volt) that has a maximum allowable operating temperature of 104°F and is located in a warehouse that has a maximum outside ambient air temperature of 92°F.

Power to be dissipated is stated in the specifications of the GS3-2020 and is found to be 750 watts, so P=750 watts

Delta T = Max. operating temperature for the GS3-2020 is 104°F – Max. ambient air temperature of 92°F

Delta T = 9°F

CFM = (3.17 x 750 watts) / 12°F

CFM = 198

Choose a Stego 018740-30 230VAC FPI filter fan with a 118740-00 exhaust grille to provide 220 CFM or a Stego 018840-00 230VAC FPO filter fan with a 118840-30 intake grille to provide 243 CFM.

Air Conditioner Selection Example

A NEMA 12 Hubbell Wiegmann N12302412 enclosure (30" high x 24" wide x 12" deep) contains a GS3-4030 AC drive (30 HP 460 volt) that has a maximum allowable operating temperature of 104°F and is located in a warehouse that has a maximum outside ambient air temperature of 115°F.

Power to be dissipated is stated in the specifications of the GS3-4030 and is found to be 1290 watts.

Internal heat load:

BTU per Hour = 1290 watts x 3.413

BTU per Hour = 4403 BTU/H

Heat load transfer:

Heat load transfer (BTU/H) = 1.25 x 19 sq. ft. x (115°F – 104°F)

Heat load transfer (BTU/H) = 261.25 BTU/H

Cooling capacity:

Cooling capacity (BTU/H) = 4403 BTU/H + 261.25 BTU/H

Cooling capacity (BTU/H) = 4664.25 BTU/H

In this example, you are able to determine that a 5000 BTU/H unit is needed. Select a TA10-050-16-12 Stratus air conditioner.

NOTE: THE SAME CALCULATION METHOD IS USED FOR SIZING STRATUS VORTEX COOLERS. HOWEVER, IN THIS EXAMPLE THE COOLING REQUIREMENTS EXCEED THE MAXIMUM CAPACITY OF THE LARGEST AVAILABLE VORTEX COOLER. IF THE EXAMPLE APPLICATION REQUIRED THE USE OF A VORTEX COOLER INSTEAD OF AN AIR CONDITIONER, TWO (2) TV35-025-4X UNITS WOULD BE NEEDED.

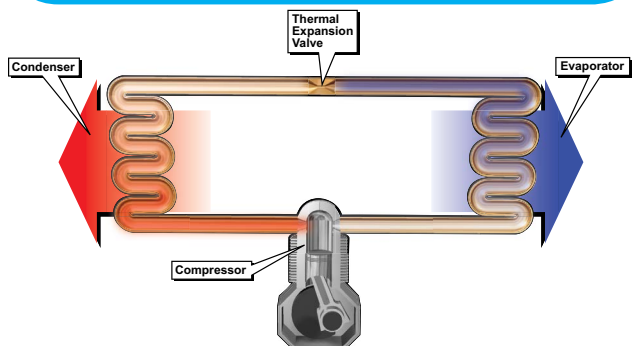



Hose-Proof Hood for Stego Fans



Features

- Stainless steel hood
- Food-safe silicone seal
- Increase of protection class to UL Type 4X
- Easy to clean
- Filter mat change from outside
- Impact-resistant
- Optional security feature to restrict unauthorized access (M6x1 security screw included)
- Weather resistant
- Versatile
- Protective grid
- Mounting screws provided

Standards

- UL 4/4X when used with STEGO Filter Fan Plus and Filter Fans
- UL Recognized File No. E234324
- RoHS 2 compliant
- IP56

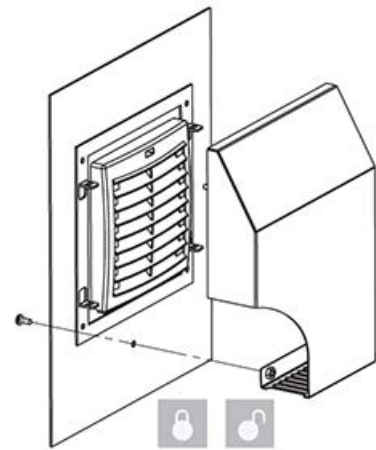

Hose-Proof Hood Locking Mechanism

Applications

- Designed to increase the protection class and serve as a protective cover to filter fans, intake and exit filters.
- Used for protection against water projected by a hose and extreme climatic influences if located outdoors in industrial applications with harsh environmental conditions.
- Hood removes easily for cleaning and filter change without opening the enclosure.

Hose-Proof Hood for Stego Fans						
Part Number	Price	Stego Filter Fan Plus FPI/FPO Cutout Size	Stego Filter Fan Cutout Size	Dimensions (H x W x D)	Max. Covered Area (X x Y)	Weight (lb)
086700-00	\$114.00	3.62 x 3.62 [92 x 92]	3.82 x 3.82 [97 x 97]	8.42 x 7.67 x 1.88 [214 x 195 x 48]	5.27 x 5.63 [134 x 143]	1.76
086710-00	\$139.00	4.88 x 4.88 [124 x 124]	4.92 x 4.92 [125 x 125]	11.00 x 8.92 x 2.39 [280 x 226 x 61]	6.39 x 6.75 [162 x 171]	2.64
086720-00	\$157.00	6.93 x 6.93 [176 x 176]	6.93 x 6.93 [176 x 176]	14.01 x 11.44 x 2.68 [356 x 291 x 68]	9.19 x 9.19 [233 x 233]	4.40
086730-00	\$197.00	8.78 x 8.78 [223 x 223]	9.84 x 9.84 [250 x 250]	16.19 x 14.5 x 3.07 [411 x 388 x 78]	11.69 x 11.31 [297 x 287]	6.17
086740-00	\$248.00	11.46 x 11.46 [291 x 291]	N/A	18.94 x 15.96 x 4.05 [481 x 405 x 103]	13.25 x 13.31 [337 x 338]	8.15

*Dimensions in inches [millimeters].
None of the above models fit 018210-04 and 018210-02 outdoor filter fans.*

