



500W to 700W Space-Saving Fan Heaters



35mm DIN Rail Mounting



Panel Mounting

Applications

These compact high-performance fan heaters help to prevent the formation of condensation and provide an evenly distributed interior air temperature in enclosures with electric/electronic components. These fan heaters are available with two different mounting systems – panel mounting or 35mm DIN rail mounting.

Features

- Compact size
- Flat design
- Built-in overheat protection
- DIN rail or panel mountable



500W to 700W Space-Saving Fan Heaters Specifications		
	35mm DIN Rail Mount	Panel Mount
Heating Element	High performance cartridge	
Temperature Safety Cut-Out	With automatic reset and second-tier one shot fuse	
Axial Fan, Ball Bearing	Service life 50,000h at 77°F [25°C]	
Connection	2-pole dual pressure clamp 14 AWG [2.5 mm ²], max. solid wire 16 AWG [1.5 mm ²] max. stranded wire with wire end ferrule	
Housing	Plastic, UL 94V-0, black	
Mounting	Twist clip for 35mm DIN rail, EN 60715	M6 screws and washers (not included), torque 2 N·m max.
Mounting Position	Vertical airflow (air outlet up)	
Operating/Storage Temperature	-49 to 158°F [-45 to 70°C]	
Recommended Mounting Distance	Sides: 0.79 in [20mm] Bottom: 3.94 in [100mm] Above: 5.91 in [150mm]	
Operating / Storage Humidity	Max. 90% RH (non-condensing)	
Protection Class	Heater: II (double insulated), fan: I (grounded)	
Protection Type	IP20	
Approvals	CE, UL Recognized File No. E234324, RoHS 2 compliant	

To obtain the most current agency approval information, see the Agency Approval Checklist section on the specific part number's web page at www.AutomationDirect.com

500W to 700W Space-Saving Fan Heaters								
Part Number DIN Rail Mount	Price	Part Number Panel Mount	Price	Heating Capacity ¹	Operating Voltage	Max. current (inrush)	Air flow, free blowing	Weight (approx.)
030849-00	\$148.00	030849-01	\$148.00	500W	120V AC, 50/60 Hz	6.3 A	88 cfm [150 m ³ /h]	49.6 oz [1406g]
030840-00	\$148.00	030840-01	\$148.00		230V AC, 50/60 Hz	3.15 A		
030839-00	\$151.00	030839-01	\$151.00	600W	120V AC, 50/60 Hz	6.3 A		
030830-00	\$151.00	030830-01	\$151.00		230V AC, 50/60 Hz	3.15 A		
030829-00	\$173.00	030829-01	\$173.00	700W	120V AC, 50/60 Hz	8.0 A		
030820-00	\$173.00	030820-01	\$173.00		230V AC, 50/60 Hz	4.0 A		

Note: ¹At 68°F [20°C] ambient temperature @ 60Hz



500W to 700W Space-Saving Fan Heaters

Dimensions:

Twist Clip Mounting Models

Inches [mm]

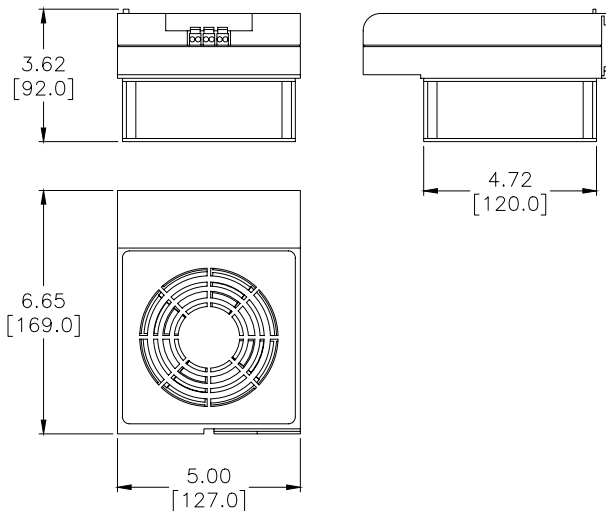

Screw Mounting Models

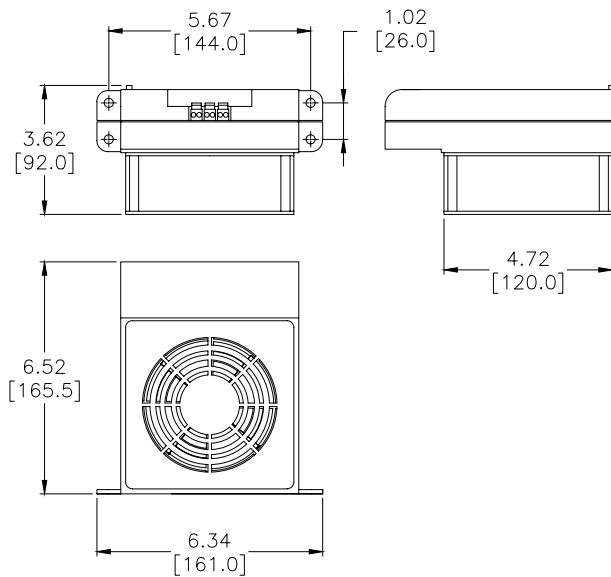

Please see our website www.AutomationDirect.com for complete engineering drawings.

Wiring Diagram

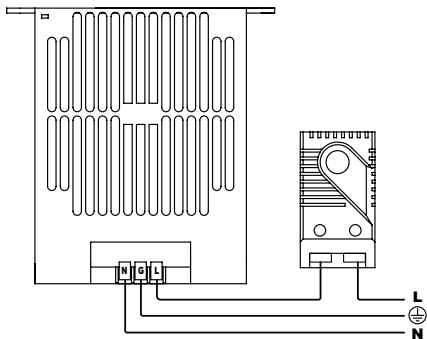

Note: When wiring 230 volt units for North American installations "L" (line) and "N" (neutral) will be used as "L1" (line1) "L2" (line2) respectively with no neutral connection.

Enclosure Heating and Heater Selection

Why Heat an Enclosure?

Today's miniaturization of enclosure components results in high packing densities, which in turn results in higher temperatures within the enclosure. These high temperatures are harmful to electronic components. In response, cooling systems have become standard in many applications. However, just as critical and widely underestimated, are failures caused by the formation of moisture.

Under certain climatic conditions, moisture can build up not only in outdoor or poorly insulated enclosures, but also in highly protected and well-sealed enclosures.

Moisture and Failure

Moisture, especially when combined with aggressive gases and dust, causes atmospheric corrosion and can result in the failure of components such as circuit breakers, busbars, relays, integrated circuit boards and transformers. The greatest danger lies in conditions where electronic equipment is exposed to relatively high air humidity or extreme variations in temperature, such as day-and-night operation or outdoor installation. Failure of components in such cases is usually caused by changing contact resistances, flashovers, creepage currents or reduced insulation properties.

Eliminate Moisture

Moisture and corrosion will remain low if relative air humidity stays below 60%. However, relative humidity above 65% will significantly increase moisture and corrosion problems. This can be prevented by keeping the environment inside an enclosure at a temperature as little as 9°F (5°C) higher than that of the ambient air. Constant temperatures are a necessity to guarantee optimal operating conditions. Continuous temperature changes not only create condensation but they reduce the life expectancy of electronic components significantly. Electronic components can be protected by cooling during the day and heating at night.

Thermal Management

Modern enclosure heaters are designed to protect against condensation. They heat the air inside enclosures, preventing water vapor from condensing on components while providing the greatest possible air circulation and low energy consumption.

Other heating element technology improvements include:

- Longer operating life
- Greater energy efficiencies
- Quick wiring options
- Easier mounting
- Fan heaters should be considered for larger enclosures to ensure that the entire enclosure is heated uniformly

Heater Location

Ideally, most heaters will perform optimally when mounted near the bottom of an enclosure and used in conjunction with a control device, thermostat, and/or hygrostat. The control device may be a separate device, or it may be integral to the heater. With the controller located in an area of the cabinet that is representative of the average temperature or humidity

requirement, the heater should then be placed in a position near the bottom of the enclosure. If a separate control device is used, the heater should not be located directly beneath the controller to ensure that the controller is not influenced by direct heat from the heater.

Heater Calculation

Follow Steps 1-5 to determine the heating requirement of an enclosure (US units - left column, metric - right)

STEP 1: Determine the Surface Area (A) of your enclosure which is exposed to open air.

Enclosure Dimensions:

height = _____ feet _____ meters

width = _____ feet _____ meters

depth = _____ feet _____ meters

Choose Mounting Option from next page, and calculate the surface area as indicated

$$A = \text{_____ ft}^2 \text{ or } \text{_____ m}^2$$

STEP 2: Choose the Heat Transmission Coefficient (k) for your enclosure's material of construction.

painted steel = 0.511 W/(ft²•K) 5.5 W/(m²•K)

stainless steel = 0.344 W/(ft²•K) 3.7 W/(m²•K)

aluminum = 1.115 W/(ft²•K) 12 W/(m²•K)

plastic or insulated

stainless = 0.325 W/(ft²•K) 3.5 W/(m²•K)

$$k = \text{_____ W/(ft}^2\text{•K)} \text{ or } \text{_____ W/(m}^2\text{•K)}$$

STEP 3: Determine the Temperature Differential (ΔT).

A. Desired enclosure interior temp. = _____ °F _____ °C

B. Lowest ambient (outside) temp. = _____ °F _____ °C

Subtract B from A = Temp. diff. (ΔT) = _____ °F _____ °C

For these calculations, ΔT must be in degrees Kelvin (K). Therefore, divide ΔT (°F) by 1.8. ΔT = _____ K

STEP 4: Determine Heating Power (P_V), if any (generated from existing components, i.e. transformer).

$$P_V = \text{_____ W} \text{ or } \text{_____ W}$$

STEP 5: Calculate the Required Heating Power (P_H) for your enclosure based on the above values.

If enclosure is located inside:

$$P_H = (A \times k \times \Delta T) - P_V = \text{_____ W}$$

If enclosure is located outside:

$$P_H = 2 \times (A \times k \times \Delta T) - P_V = \text{_____ W}$$

Enclosure Mounting Types and Surface Area Calculations

1. Free-Standing

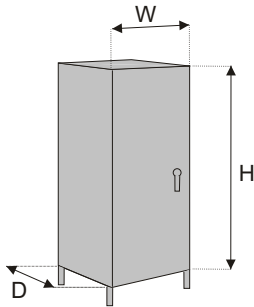

$$\text{Area (A)} = 1.8 (H \times W) + 1.8 (H \times D) + 1.8 (W \times D)$$

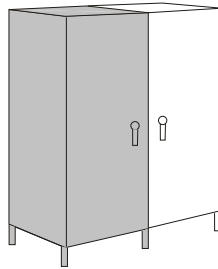

$$\text{Area (A)} = 1.8 (H \times W) + 1.4 (H \times D) + 1.8 (W \times D)$$

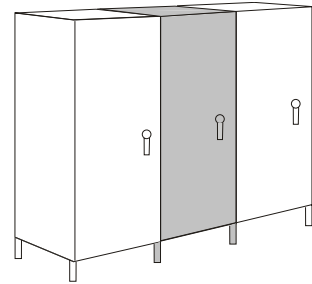

$$\text{Area (A)} = 1.8 (H \times W) + (H \times D) + 1.8 (W \times D)$$

2. Wall-Mounted

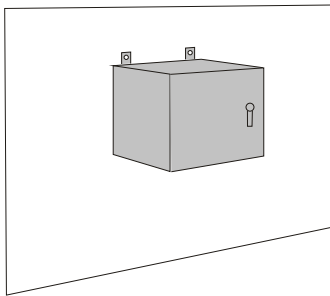

$$\text{Area (A)} = 1.4 (H \times W) + 1.8 (H \times D) + 1.8 (W \times D)$$

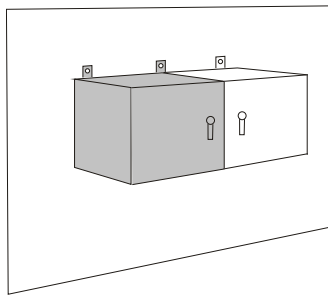

$$\text{Area (A)} = 1.4 (H \times W) + 1.4 (H \times D) + 1.8 (W \times D)$$

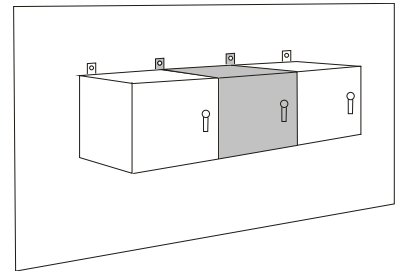

$$\text{Area (A)} = 1.4 (H \times W) + (H \times D) + 1.8 (W \times D)$$

3. Ground

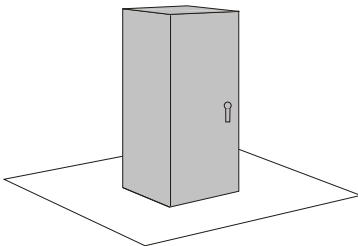

$$\text{Area (A)} = 1.8 (H \times W) + 1.8 (H \times D) + 1.4 (W \times D)$$

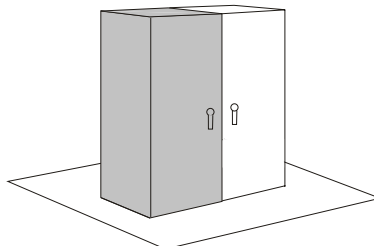

$$\text{Area (A)} = 1.8 (H \times W) + 1.4 (H \times D) + 1.4 (W \times D)$$

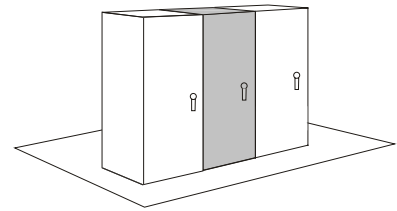

$$\text{Area (A)} = 1.8 (H \times W) + (H \times D) + 1.4 (W \times D)$$

4. Ground and Wall

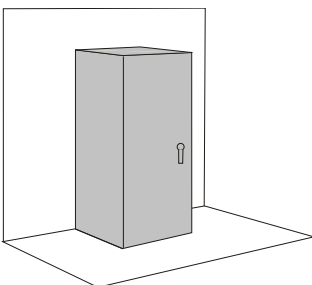

$$\text{Area (A)} = 1.4 (H \times W) + 1.8 (H \times D) + 1.4 (W \times D)$$

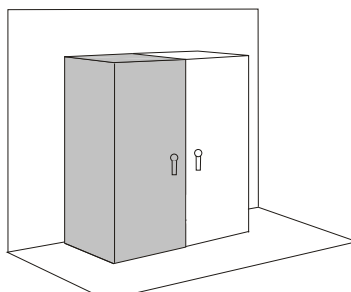

$$\text{Area (A)} = 1.4 (H \times W) + 1.4 (H \times D) + 1.4 (W \times D)$$

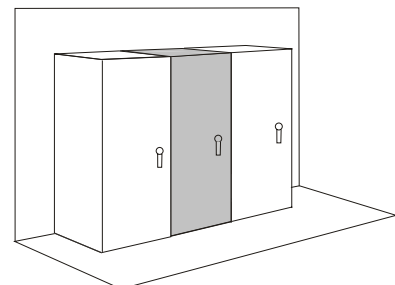

$$\text{Area (A)} = 1.4 (H \times W) + (H \times D) + 1.4 (W \times D)$$