



# RACPRO1 Series Switching Power Supplies 1-Phase

## Overview

The slim RACPRO1 series is a high-reliability, single-phase AC input, DIN rail mount power supply. It is specially designed for demanding applications in the harsh industrial automation field. The unique and innovative modern design with 25-degree push-in connectors allows easy tool-less installation or replacement.

## Features

- Slim design with 25-degree push-in connectors
- Fast tool-less mounting and demounting
- DC-OK Signal
- Thermal power bonus 120%/45 °C
- Power Boost 150% for 5s
- 3-year warranty



**RACPRO1-S240E/12**



Switching Power Supplies 1-Phase Selection Chart								
Part Number	Price	Output	Output Voltage Range	Input Voltage Range	Efficiency (@ +25 °C)	Dimensions H x W x D mm [in]	Weight gram [lb]	Drawing Link
<a href="#">RACPRO1-S120/12</a>	\$105.00	12 VDC @ 8A/96W (adjustable)	12–15 VDC	85–277 VAC / 88–370 VDC	90.3% @ 230 VAC	100.00 x 28.00 x 112.00 [3.90 x 1.10 x 4.40]	330 [0.73]	<a href="#">PDF</a>
<a href="#">RACPRO1-S120/24</a>	\$105.00	24 VDC @ 5A/120W (adjustable)	24–29 VDC		93% @ 230 VAC			<a href="#">PDF</a>
<a href="#">RACPRO1-S120/48</a>	\$105.00	48 VDC @ 2.5A/120W (adjustable)	48–56 VDC		93% @ 230 VAC			<a href="#">PDF</a>
<a href="#">RACPRO1-S240E/12</a>	\$120.00	12 VDC @ 15A/180W (adjustable)	12–15 VDC	85–132 VAC / 170–277 VAC	91.3% @ 230 VAC	125.00 x 39.00 x 139.00 [4.90 x 1.50 x 4.47]	600 [1.32]	<a href="#">PDF</a>
<a href="#">RACPRO1-S240E/24</a>	\$120.00	24 VDC @ 10A/240W (adjustable)	24–29 VDC		93.1% @ 230 VAC			<a href="#">PDF</a>
<a href="#">RACPRO1-S240E/48</a>	\$120.00	48 VDC @ 5A/240W (adjustable)	48–56 VDC		94% @ 230 VAC			<a href="#">PDF</a>
<a href="#">RACPRO1-S240/24</a>	\$158.00	24 VDC @ 10A/240W (adjustable)	24–29 VDC	85–277 VAC / 88–370 VDC	95% @ 230 VAC	135.00 x 52.00 x 155.00 [5.30 x 2.00 x 6.10]	790 [1.74]	<a href="#">PDF</a>
<a href="#">RACPRO1-S480/24</a>	\$220.00	24 VDC @ 20A/480W (adjustable)	24–28 VDC		95% @ 230 VAC			<a href="#">PDF</a>
<a href="#">RACPRO1-S480/48</a>	\$220.00	48 VDC @ 10A/480W (adjustable)	48–56 VDC		95.4% @ 230 VAC			<a href="#">PDF</a>

Switching Power Supplies 1-Phase												
Part Number	Input/Output Cage Clamp								Push-in Signal Terminal *			
	Function	AWG	mm <sup>2</sup>	Wire Stripping Length	Function	AWG	mm <sup>2</sup>	Wire Stripping Length	Function	AWG	mm <sup>2</sup>	Wire Stripping Length
<b>120, 240E and 240 Watt Models</b>	L, N	24–12	0.25–4	10–12mm	+1, +2 (Vout)	24–12	0.25–4	10–12mm	Signal (13,14)	24–16	0.25–1.5	8–9mm
	PE				-1, -2 (Vout)							
<b>480 Watt Models</b>	L, N	24–8	0.25–6	12–13mm	+1, +2 (Vout)	24–8	0.25–6	12–13mm	Signal (13,14)	24–16	0.25–1.5	8–9mm
	PE				-1, -2 (Vout)							

\* Do not connect to hazardous voltages. Ferrules are required for stranded wire.

Use flexible (stranded wire) or solid cables with above wire cross-section is recommended. Use copper conductors designed for an operating temperature of at least 90 °C.



# RACPRO1 Series Switching Power Supplies 1-Phase S480 Models

Specifications			
Models	S480		
Nominal Input Voltage	50/60 Hz		120 to 240 VAC
	DC Input	RACPRO1-S480/48	110 to 240 VDC
		RACPRO1-S480/24	120 to 240 VDC
Operating Range <sup>(1)</sup>	47–63 Hz		85 to 277 VAC
	Refer to Connections for DC Operation		88 to 370 VDC
Turn-on Voltage	AC Operation		Typical 75 VAC
	DC Operation		Typical 81 VDC
Turn-off Voltage	AC Operation		Typical 60 VAC
	DC Operation		Typical 53 VDC
Input Current	AC Operation	120 VAC	Typical 4.3A
		240 VAC	Typical 2.2A
	DC Operation	110 VDC	Typical 4.7A
		240 VDC	Typical 2.1A
Inrush Current	Cold Start	120 VAC	Typical 14.2A
		240 VAC	Typical 8.4A
		120 VAC	Typical 4.2W
No Load Power Consumption	240 VAC		Typical 2.2W
	240 VAC		Typical 2.2W
Input Frequency Range	—		47–63 Hz
Nominal Output Voltage (Factory Set)	RACPRO1-S480/24		Typical 24 VDC
	RACPRO1-S480/48		Typical 48 VDC
Minimum Load	—		0%
Power Factor	Full Load		Typical 0.94
Start-up Time	240 VAC	RACPRO1-S480/24	Typical 220 ms maximum 300 ms
		RACPRO1-S480/48	Typical 255 ms maximum 300 ms
Rise Time	240 VAC	RACPRO1-S480/24	Typical 45 ms
		RACPRO1-S480/48	Typical 85 ms
Hold-up Time	240 VAC	RACPRO1-S480/24	Typical 20 ms
		RACPRO1-S480/48	Typical 22 ms
Internal Operating Frequency	—		Typical 80 kHz
Ripple and Noise	20 MHz Bandwidth	RACPRO1-S480/24	Typical 110 mVp-p
		RACPRO1-S480/48	Typical 60 mVp-p
Housing Material	Polycarbonate (UL94 V-0) / aluminum		
Agency Approvals	cULus File E550315, CE		

<sup>(1)</sup> The products were submitted for safety files at AC and DC-Input operation. (120–240 VAC  $\pm 10\%$  and 110–240 VDC  $-15/+20\%$ )

Output power derating for Line-input of less than: 108 VAC (derate linearly from 100% at 108 VAC to 88% at 85 VAC), 120 VDC (derate linearly from 100% at 120 VDC to 88% at 85 VDC)

Measured @  $T_{AMB} = 25^\circ\text{C}$ , 240 VAC full load and after warm-up unless otherwise stated.

## Connections for DC Operation

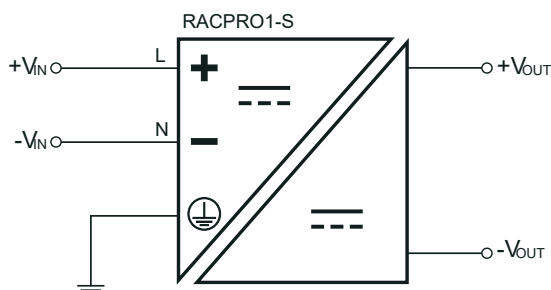



# RACPRO1 Series Switching Power Supplies 1-Phase S480 Models

## Characteristic Curves for [RACPRO1-S480/24](#)

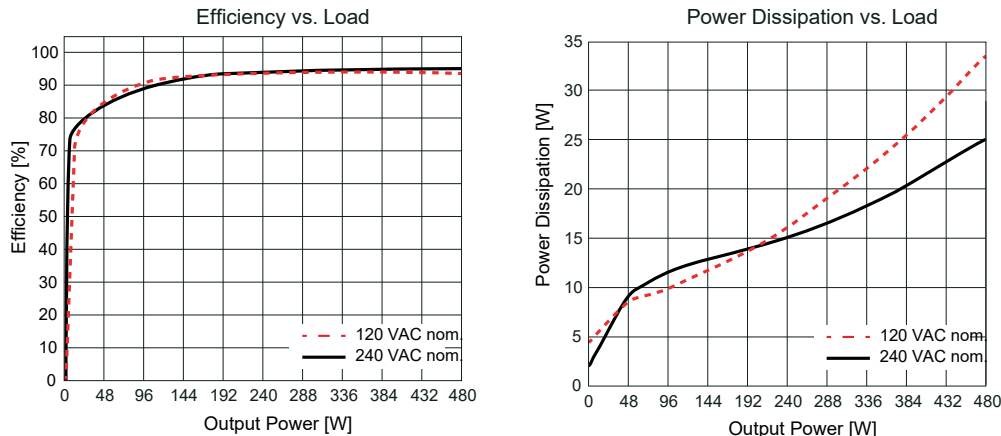

Additional Features			
Parameter	Condition	Value	
Output Voltage Adjustability <sup>(1)</sup>	On-board Potentiometer	<a href="#">RACPRO1-S480/24</a>	24–28 VDC
		<a href="#">RACPRO1-S480/48</a>	48–56 VDC
Parallel Load Share Mode	—	Refer to DIP-Switch Settings	
Boost Power	Refer to Boost Power	150% for 5s	
CC/CV Mode	DIP-Switch 2 "ON"; limited to T <sub>AMB</sub> max. 60 °C, to maintain reliability Refer to CC/CV Mode	Typical 100% I <sub>OUTLIMIT</sub> continuous	
Load Indication LED	LED green, refer to Load Indication LED	Normal Mode	
	LED off	Abnormal mode, no operation or failure	
DC-OK LED	LED green	Output voltage OK, normal mode	
	LED off	Abnormal mode, no operation or failure	
Signal Contact	Closed	Normal mode	
	Open	Abnormal mode, no operation or failure	
Signal Contact Rating	Do not connect signaling contact to hazardous voltages	<a href="#">RACPRO1-S480/24</a>	30 VDC / 0.1A
		<a href="#">RACPRO1-S480/48</a>	60 VDC / 0.1A

<sup>(1)</sup> Make sure that the maximum rated output power will not be exceeded when trimming up.

## Load Indication LED

4 LEDs displaying actual and target current of rated output current.

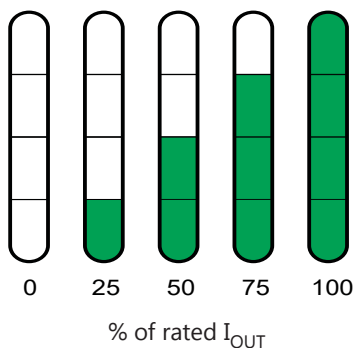



# RACPRO1 Series Switching Power Supplies 1-Phase S480 Models

## DIP-Switch Settings

### Single Mode (Factory set) \*

Power Boost Mode available, refer to Boost Power

### Parallel Load Share Mode \*\*

Angled output characteristic (droop mode) for load sharing. Voltage drop from 0 to nom.  $I_{OUT}$ : 1.2V

### Charging Mode

Current Limitation strictly at nominal current. Refer to CC/CV Mode (Charging Mode)

### Not allowed!

This would result in an output characteristic with passive load sharing and nominal output current only. This won't necessarily damage the PSU, but it will prevent the 150% boost power mode from activating. We advise against using these PSUs in this mode out of an abundance of caution.

DIP1	DIP2	
OFF	OFF	
ON	OFF	
OFF	ON	
ON	ON	

\* Series operation is allowed. A setup was successfully tested without issue using three RACPRO1-S480/48 units in series for an output of 150V. If a series configuration is to be used, it is critical that proper wiring, connections, and safety measures are in place ahead of time to prevent any converters being disproportionately loaded. For series operation, best practice is to put the PSUs in Single Mode, as this would provide full power with the 150% power boost.

\*\* This mode enables automatic current sharing between paralleled units by slightly decreasing the output voltage as output current increases. When 2+ supplies are operated in parallel, if one unit starts taking more load, its voltage drops a bit more, and the other unit(s) begins to supply more current in response to this voltage drop.

## U/I Factory Setting (Single Mode)

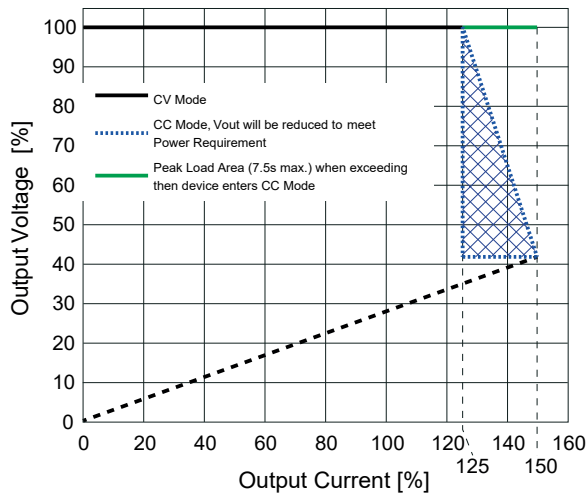

## CC/CV Mode (Charging Mode)

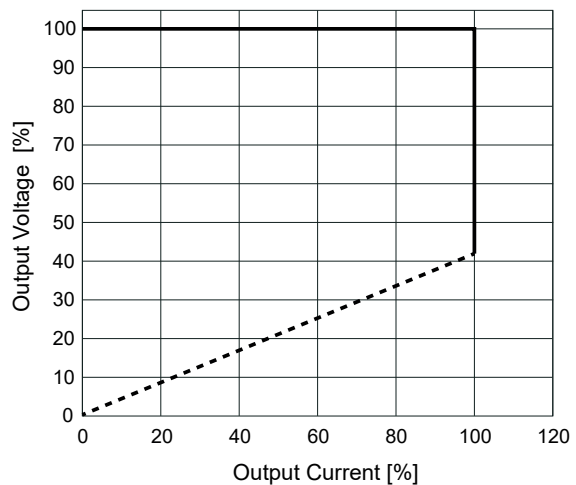

Constant Current / Constant Voltage mode. It's useful for the battery charging mode to have the output stay at the 100% rated output current. This is applicable for just the single- and three-phase 480 and 960 models



# RACPRO1 Series Switching Power Supplies 1-Phase S480 Models

Regulations		
Parameter	Condition	Value
Output Accuracy	—	Maximum $\pm 1.0\%$
Line Regulation	Low line to high line, full load	Maximum $\pm 0.5\%$
Load Regulation	0 to 100% load	Maximum $\pm 1.0\%$
Max. Capacitive Load (start-up)	RACPRO1-S480/24	20 mF
	RACPRO1-S480/48	10 mF
Transient Response	10 to 100% load	Typical $\pm 2.0\%$
	Recovery time	Typical 10 ms

Measured @  $T_{AMB} = 25^\circ\text{C}$ , 240 VAC full load and after warm-up unless otherwise stated.

Protections			
Parameter	Type	Value	
Internal Input Fuse	DC compliant	T6.3A, slow-blow	
Easy Fuse Tripping	See Easy Fuse Tripping	250% / 20 ms	
External Input Protection	—	16A max. C-characteristic circuit breaker or faster	
Short Circuit Protection (SCP)	—	Hiccup mode, auto recovery	
Over Voltage Protection (OVP)	SELV Output	RACPRO1-S480/24	35 VDC, latch off
		RACPRO1-S480/48	59.8 VDC, latch off
Return Voltage Immunity	Continuous	RACPRO1-S480/24	35 VDC maximum
		RACPRO1-S480/48	63 VDC maximum
	<5 min	RACPRO1-S480/24	38 VDC maximum
		RACPRO1-S480/48	68 VDC maximum
Absorbing Energy	RACPRO1-S480/24	1J	
	RACPRO1-S480/48	1.3J	
Over Voltage Category (OVC)	—	OVC II	
Over Current Protection (OCP)	<5s	>150% of rated load current, hiccup mode, auto recovery	
	<20 ms <sup>(1)</sup>	>250% of rated load current, hiccup mode, auto recovery	
Class of Equipment	—	Class I with PE connection	
Isolation Voltage (safety certified) <sup>(2)</sup>	I/P to O/P (tested for 1 minute)	3 kVAC / 4 kVDC	
	I/P to PE (tested for 1 minute)	1.6 kVAC / 2.5 kVDC	
	O/P to PE (tested for 1 minute)	500 VAC / 700 VDC	
Isolation Resistance	I/P to O/P	4.5 M $\Omega$ minimum	
Insulation Grade	—	Reinforced	
Earth Leakage Current	240 VAC / 60 Hz	3.5 mA maximum	

Measured @  $T_{AMB} = 25^\circ\text{C}$ , 240 VAC full load and after warm-up unless otherwise stated.

<sup>(1)</sup> RACPRO1-S480/24 = 19 VDC min.; RACPRO1-S480/48 = 40 VDC min.

<sup>(2)</sup> For repeat Hi-Pot testing, reduce the time and/or the test voltage.

## Easy Fuse Tripping

(120–240 VAC or 240 VDC;  
-40 to +60 °C max.)

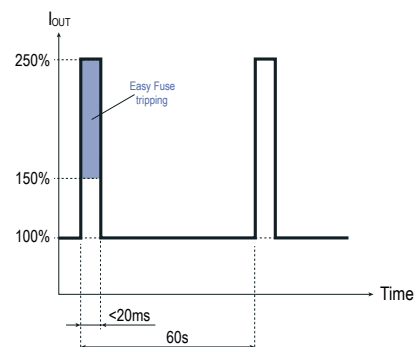

Easy fuse tripping is designed to trip a fuse in the event of a short circuit. Once the fuse has tripped, the current returns to its normal operation value. The impulse that causes easy fusing tripping happens independently of the power boost.



# RACPRO1 Series Switching Power Supplies 1-Phase S480 Models

Environmental		
Parameter	Condition	Value
<b>Operating Ambient Temperature Range</b>	At Natural Convection (0.1m/s)	Derating: -40 to +70 °C [-40 to +158 °F] Without derating refer to Derating graph
<b>Operating Altitude</b>	Refer to Altitude Derating Graph	Recognized by safety agency for safe operation up to 5000m. High altitude operation may impact the performance and lifetime.
<b>Operating Humidity</b>	Non-condensing	95% RH max.
<b>Pollution Degree</b>	—	PD2
<b>IP Rating</b>	—	IP20
<b>Shock</b>	According to IEC 60068-2-27 Fa (non-operating)	15G/11 ms, 3 times (positive/negative) in all axis
<b>Vibration</b>	According to IEC 60068-2-6 Fc (non-operating)	5–8.4 Hz @ 3.5mm deflection 8.4–150 Hz @ 2G, 10 cycles /axis (min-max-min); 1 octave/min
<b>MTBF</b>	According to EN/IEC 61709 (SN29500), T <sub>AMB</sub> = 40 °C	685 x 10 <sup>3</sup> hours
<b>Lifetime Expectancy (1)</b>	230 VAC	Refer to lifetime expectancy table

Measured @ T<sub>AMB</sub> = 25 °C, 240 VAC full load and after warm-up unless otherwise stated.

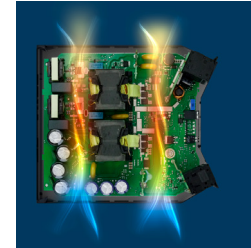

10° C reduction in heating = Doubling the Lifetime

Lifetime Expectancy at 230 VAC for RACPRO1-S480/24			
Ambient Temperature	50% Load	75% Load	100% Load
+20 °C	582 x 10 <sup>3</sup> h	487 x 10 <sup>3</sup> h	323 x 10 <sup>3</sup> h
+30 °C	291 x 10 <sup>3</sup> h	243 x 10 <sup>3</sup> h	162 x 10 <sup>3</sup> h
+40 °C	145 x 10 <sup>3</sup> h	122 x 10 <sup>3</sup> h	81 x 10 <sup>3</sup> h

The stated lifetime expectancy of more than 15 years is provided for comparison purposes only and does not imply continuous 24/7 operation.

## Derating Graph

(@ Chamber and natural convection 0.1m/s)

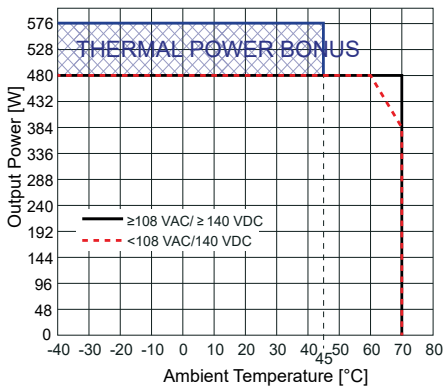

Thermal power bonus only applies at an input voltage ≥108 VAC and ≥120 VDC

## Boost Power

(-40 to +60 °C max)

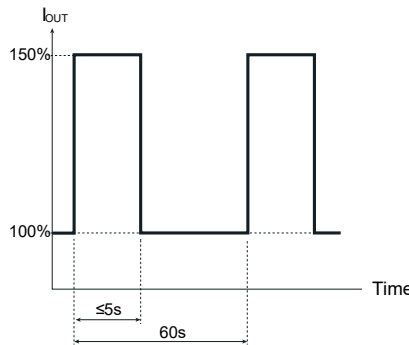

## Altitude Derating

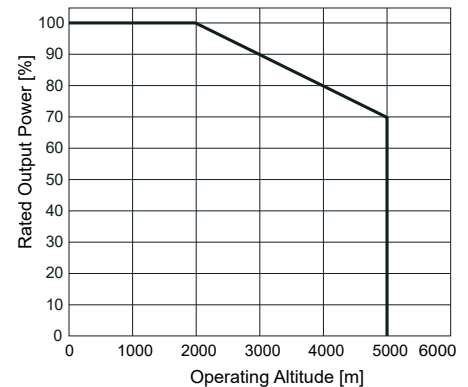



# RACPRO1 Series Switching Power Supplies 1-Phase S480 Models

## Safety & Certifications 1-Phase S480 RACPRO1 Series

Certificate Type (Safety)	Report Number	Standard
Electrical Equipment For Measurement, Control, and Laboratory Use; Part 1: General Requirements (CB)	25TH0250_61010-1_0	IEC61010-1:2010+A1:2016 3rd Edition
Electrical Equipment For Measurement, Control, and Laboratory Use; Part 1: General Requirements		EN61010-1:2010+A1:2019
Electrical Equipment For Measurement, Control, and Laboratory Use; Part 1: General Requirements	E550315	UL61010-1:2012 3rd Edition CAN/CSA-C22.2 No. 61010-1-12 3rd Edition
Electrical Equipment For Measurement, Control, and Laboratory Use; Part 2-201: Particular requirements for control equipment (CB)	25TH0250_61010-1_0	IEC61010-2-201:2017 2nd Edition EN IEC 61010-2-201:2018
Electrical Equipment For Measurement, Control, and Laboratory Use; Part 2-201: Particular requirements for control equipment	E550315	UL61010--2-201:2018 2nd Edition CAN/CSA-C22.2 No. 61010-2-201:2018-02-01
RoHS2	—	RoHS 2011/65/EU + AM2015/863

## EMC Compliance According to IEC/EN61000-6-4/6-2 1-Phase S480 RACPRO1 Series

EMC Compliance according to IEC/EN61000-6-4/6-2	Condition	Standard / Criterion
Electromagnetic compatibility (EMC) - Part 6-2: Generic standards - Immunity standard for industrial environments	—	IEC/EN61000-6-2:2019
Electromagnetic compatibility (EMC) - Part 6-3: Generic standards - Emission standard for residential area	—	IEC/EN 61000-6-3:2021
ESD Electrostatic discharge immunity test	Air: $\pm 8$ kV; Contact: $\pm 6$ kV	IEC61000-4-2:2008, Criteria A EN61000-4-2:2009, Criteria A
Radiated, radio-frequency, electromagnetic field immunity test	10 V/m (80–1000 MHz)	IEC/EN61000-4-3:2006+A2:2010, Criteria A
Fast Transient and Burst Immunity	AC Power Port $\pm 4$ kV DC Output Port: $\pm 2$ kV	IEC/EN61000-4-4:2012 Criteria A
Surge Immunity	AC-Power Port: L-N: $\pm 2$ kV L-PE, N-PE,: $\pm 4$ kV DC-Output Port: Vout(+) - Vout(-): $\pm 1$ kV Vout(+)-PE, Vout(-)-PE: $\pm 1$ kV	IEC/EN61000-4-5:2014+A1:2017, Criteria A
Immunity to conducted disturbances, induced by radio-frequency fields	10 Vrms (0.15–80 MHz)	IEC61000-4-6:2013, Criteria A EN61000-4-6:2014, Criteria A
Power Magnetic Field Immunity	30 A/m, 50/60 Hz	EN61000-4-8:2010 Criteria A
Voltage Dips (230 VAC, 50 Hz)	100% 5 cycles 70% 10 cycles 40% 25 cycles 30% 25 cycles	IEC61000-4-11:2004+A1:2017, Criteria B
Voltage Interruptions (230 VAC, 50 Hz)	100% 250 cycles	IEC61000-4-11:2004+A1:2017, Criteria B
Limits of Harmonic Current Emissions	—	EN IEC 61000-3-2:2019
Limits of Voltage Fluctuations & Flicker	—	IEC61000-3-3:2013+A1:2017

## Block Diagram

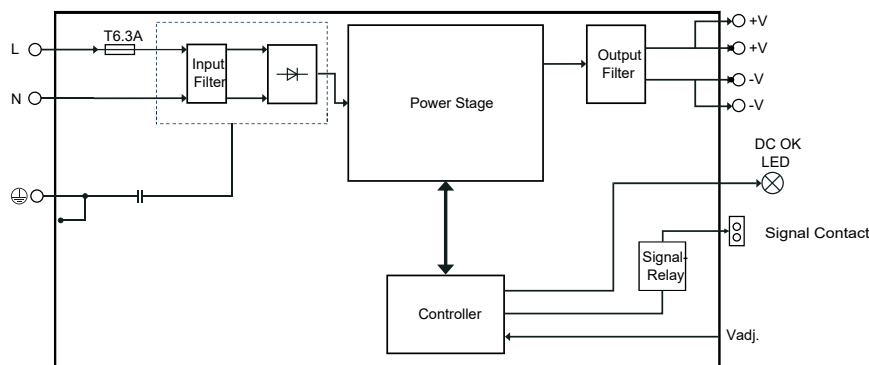



# RACPRO1 Series Switching Power Supplies 1-Phase S480 Models

## Parallel Operation for Redundancy 1+1

- 1) Adjust each power supply to the exact same output voltage with the same load and cooling conditions.
- 2) Use the same wire length and cable cross-section for each power supply (star connection) and energize all units at the same time to avoid triggering overload protection.
- 3) It must be ensured that one of the power supplies is able to provide the total required output power of the DC load to be supplied.
- 4) In normal operation, each of the two power supplies will be utilized by up to 50%.
- 5) **Attention:** To prevent high reverse currents in the event of a secondary output fault, it is recommended to install a protective circuit at the output of each device when more than two power supplies are connected in parallel (e.g. decoupling diode or DC fuse). Leakage current, EMI, inrush current, harmonics will increase when using multiple power supplies.

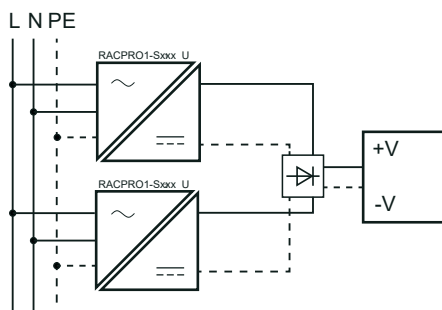

**Please Note:** This basic redundancy configuration does not protect against internal short circuits on the secondary side. In such cases, the faulty unit may draw current from the remaining supplies, resulting in loss of output regulation. To prevent this, use redundancy modules with integrated decoupling elements. RECOM offers the [RACPRO1-RD40](#) redundancy module as a suitable solution for this purpose:

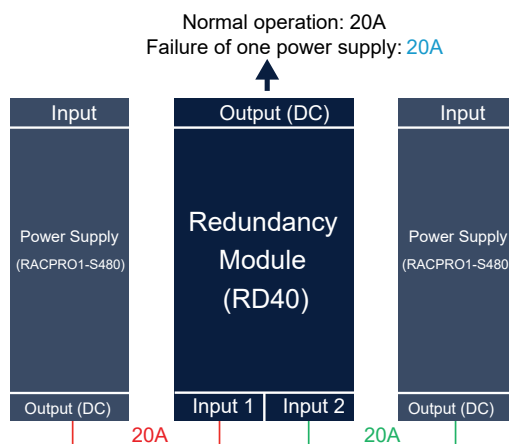



# RACPRO1 Series Switching Power Supplies 1-Phase S480 Models

## Parallel Operation for Increasing Output Power 1+n

- 1) Make sure that the DIP-Switch 1 is "ON" to get into the Parallel Load sharing mode.
- 2) Adjust each power supply to the exact same output voltage with the same load and cooling conditions.
- 3) Use the same wire length and cable cross-section for each power supply (star connection) and energize all units at the same time to avoid triggering overload protection.
- 4) A 10% safety margin may be recommended because the power distribution may be slightly asymmetrical depending on the cabling.
- 5) **Attention:** To prevent high reverse currents in the event of a secondary output fault, it is recommended to install a protective circuit at the output of each device when more than two power supplies are connected in parallel (e.g. decoupling diode or DC fuse). Leakage current, EMI, inrush current, harmonics will increase when using multiple power supplies.

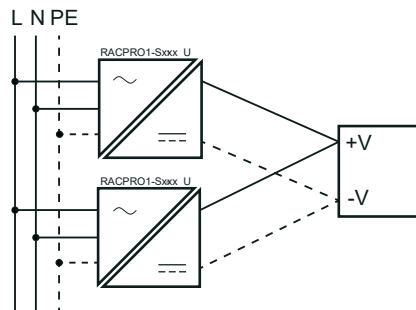

## Series Operation

- 1) Only use PSU with the same type and performance class with identical parameters.
- 2) To increase the DC output voltage, connect 2 or more power supply units in series.
- 3) Therefore, negative output terminal "-1" of the first power supply unit must be connected to the positive output terminal "+1" of the second power supply unit and routed to the load. Depending on the common output-side earth reference point of the power supply unit, see below table/figures as example.
- 4) **Attention:** Leakage current, EMI, inrush current, harmonics will increase when using power supplies.

Example with 2 PSUs In Series			
Part Number	Figure 1	Figure 2	Figure 3
<b>RACPRO1-S480/24</b>	+48 VDC	-48 VDC	±24 VDC
<b>RACPRO1-S480/48</b>	+96 VDC	-96 VDC	±48 VDC

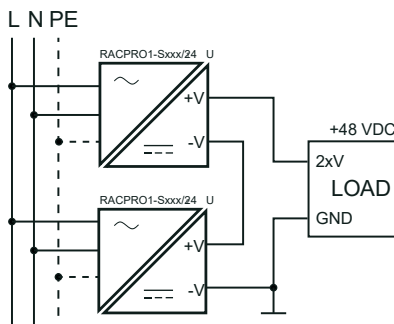

Figure 1

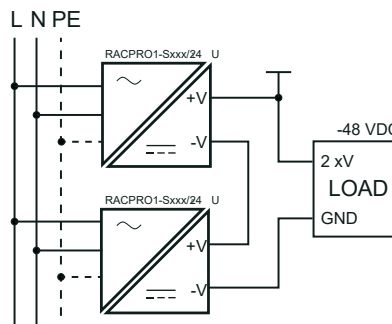

Figure 2

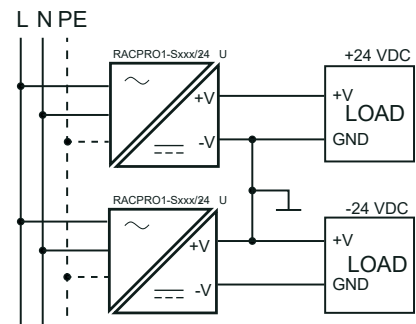

Figure 3