

# Discrete Input Terminals

## PX-144 \$53.00

### Four-point, 24VDC Discrete Input Terminal

The PX-144 (type 1) DC Input Terminal provides four electrically isolated 24VDC sinking inputs with LED status. For use with 3-wire and 2-wire sensors.

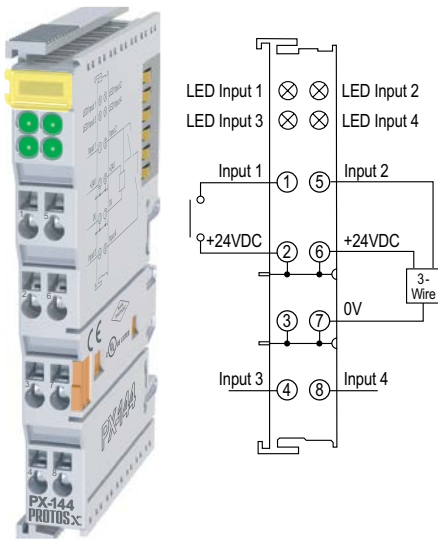

General Specifications	
<b>Operating Temp</b>	32 to 131 °F (0 to 55 °C)
<b>Storage Temp</b>	-13 to 185 °F (-25 to 85 °C)
<b>Relative Humidity</b>	5% to 95%, non-condensing
<b>Environment Air</b>	No corrosive gases permitted
<b>Mounting/Orientation Restrictions</b>	35mm DIN rail/None
<b>Vibration</b>	Conforms to EN 60068-2-6
<b>Shock</b>	Conforms to EN 60068-2-27/ EN 60068-2-29
<b>Noise Immunity</b>	Conforms to EN 61000-6-2/ EN61000-6-4
<b>Protection Class</b>	IP20
<b>Weight</b>	55g (1.9 oz)
<b>Dimensions (WxHxD)</b>	12 x 100 x 68.8 mm (0.47 x 3.94 x 2.71 in)
<b>Adjacent Mounting on Bus Terminals with Power Contact</b>	Yes, DC only
<b>Adjacent Mounting on Bus Terminals without Power Contact</b>	No
<b>Passes Terminal Bus Power</b>	Yes
<b>Passes PE Bus</b>	No
<b>Agency Approvals*</b>	UL/cUL File No. E157382, CE

Terminal Specifications	
<b>Inputs Per Terminal</b>	4
<b>Input Type</b>	Sinking
<b>Input Data Bytes Used</b>	1/2 byte (4 bits)
<b>Input Power Source</b>	24VDC provided via terminal power bus
<b>Current Consumption (from Terminal Power Bus)</b>	5mA typical
<b>Operating Voltage Rating</b>	24VDC (-15%/+20%)
<b>Peak Voltage Rating</b>	30VDC
<b>ON Voltage Level</b>	15 to 30 VDC
<b>OFF Voltage Level</b>	-3 to +5 VDC
<b>Minimum ON Current</b>	50mA
<b>Maximum OFF Current</b>	100mA
<b>Current Consumption (from I/O Bus)</b>	5mA typical
<b>Electrical Isolation</b>	500Vms (I/O bus/field potential)
<b>Heat Dissipation</b>	1W max
<b>OFF to ON Response</b>	3ms
<b>ON to OFF Response</b>	3ms
<b>Status Indicators</b>	4, indicates input is ON

\*To obtain the most current agency approval information, see the Agency Approval Checklist section on the specific part number's web page.

## PX-148 \$86.00

### Eight-point, 24VDC Discrete Input Terminal

The PX-148 (type 1) DC Input Terminal provides eight electrically isolated 24VDC sinking inputs with LED status.

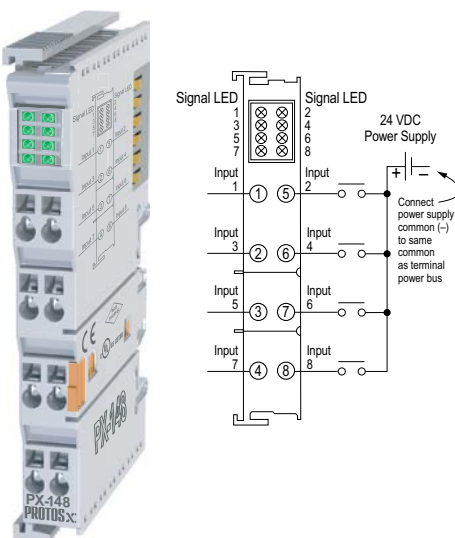

General Specifications	
<b>Operating Temp</b>	32 to 131 °F (0 to 55 °C)
<b>Storage Temp</b>	-13 to 185 °F (-25 to 85 °C)
<b>Relative Humidity</b>	5% to 95%, non-condensing
<b>Environment Air</b>	No corrosive gases permitted
<b>Mounting/Orientation Restrictions</b>	35mm DIN rail/None
<b>Vibration</b>	Conforms to EN 60068-2-6
<b>Shock</b>	Conforms to EN 60068-2-27/ EN 60068-2-29
<b>Noise Immunity</b>	Conforms to EN 61000-6-2/ EN61000-6-4
<b>Protection Class</b>	IP20
<b>Weight</b>	55g (1.9 oz)
<b>Dimensions (WxHxD)</b>	12 x 100 x 68.8 mm (0.47 x 3.94 x 2.71 in)
<b>Adjacent Mounting on Bus Terminals with Power Contact</b>	Yes, DC only
<b>Adjacent Mounting on Bus Terminals without Power Contact</b>	No
<b>Passes Terminal Bus Power</b>	Yes
<b>Passes PE Bus</b>	No
<b>Agency Approvals*</b>	UL/cUL File No. E157382, CE

Terminal Specifications	
<b>Inputs Per Terminal</b>	8
<b>Input Type</b>	Sinking
<b>Input Data Bytes Used</b>	1 byte
<b>Input Power Source</b>	Requires external 24VDC power source
<b>Current Consumption (from Terminal Power Bus)</b>	2mA + load, typical
<b>Operating Voltage Rating</b>	24VDC (-15%/+20%)
<b>Peak Voltage Rating</b>	30VDC
<b>ON Voltage Level</b>	15 to 30 VDC
<b>OFF Voltage Level</b>	-3 to +5 VDC
<b>Minimum ON Current</b>	2mA
<b>Maximum OFF Current</b>	1.5 mA
<b>Current Consumption (from I/O Bus)</b>	5mA typical
<b>Electrical Isolation</b>	500Vms (I/O bus/field potential)
<b>Heat Dissipation</b>	1W max
<b>OFF to ON Response</b>	3ms
<b>ON to OFF Response</b>	3ms
<b>Status Indicators</b>	8, indicates input is ON

\*To obtain the most current agency approval information, see the Agency Approval Checklist section on the specific part number's web page.

# System Installation and Removal

## Bus Coupler and Bus Terminal Installation

### Bus Coupler Installation:

1. Attach a Bus Coupler by snapping it onto 35mm DIN rail and securing it into position using the DIN rail locking wheel (where applicable) located on the left side of the coupler.

### Bus Terminal Installation:

2. To add a bus terminal, insert unit onto right side of Bus Coupler using the tongue and groove at the top and bottom of the unit, pressing gently until it snaps onto the DIN rail.

- A proper connection cannot be made by sliding the units together on the DIN rail. When correctly installed, no significant gap can be seen between the attached units. Bus connection is made through the six slide contacts located on the upper right side of the units. Add up to 64 bus terminals per Bus Coupler, including a bus end terminal.

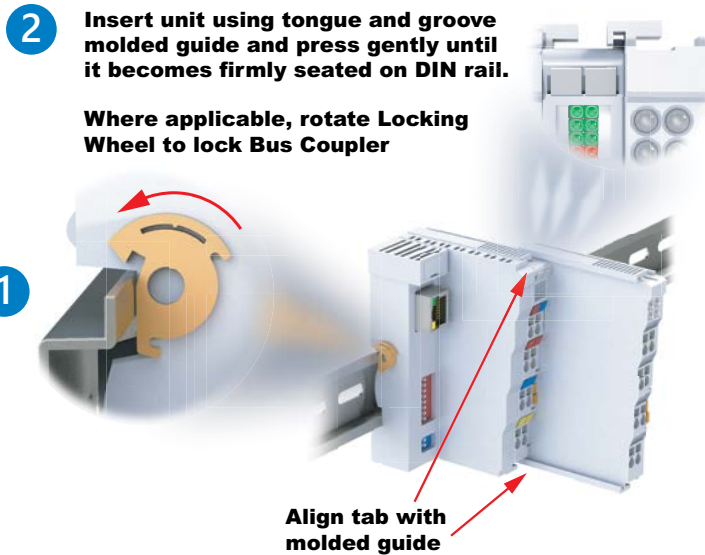

### Wiring Connections

- Wire connection is made through a spring clamp style terminal. This terminal is designed for a single-conductor solid or stranded wire. Wire connection is made by firmly pushing the screwdriver into the screwdriver slot, inserting the wire into the wire slot and removing the screwdriver, locking the wire into position.

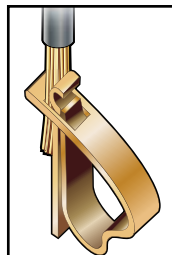
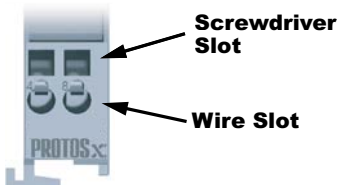

Wiring Specifications	
Connection Type	Spring Clamp Terminals
Wire Gauge	28–14 AWG (0.08–2.5 mm <sup>2</sup> )
Screwdriver Width	2.5 mm (0.10 in) such as P/N TW-SD-MSL-2
Wire Stripping Length	8mm

\* For Thermocouple terminals, thermocouple extension wire is recommended

## Removing Bus Coupler and Bus Terminals

- A locking mechanism prevents individual units from being pulled off. For bus terminal removal, pull the orange DIN rail release tab firmly to unlatch the unit from the rail. If attached to other terminal units, slide unit forward until released. For Bus Couplers with locking wheels, release the DIN rail locking wheel, then pull firmly on DIN rail release tab.

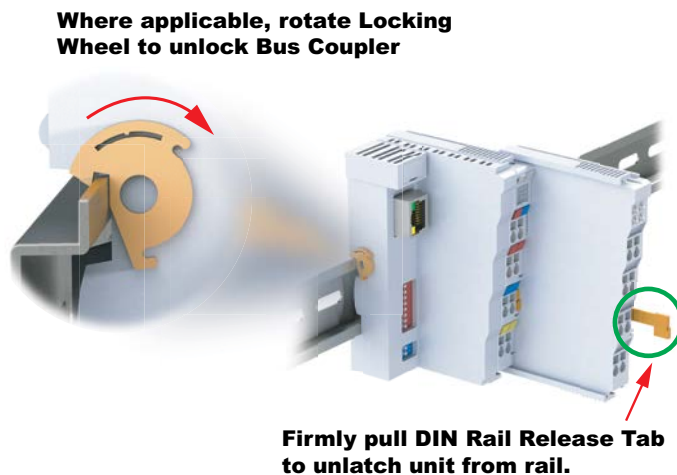

# Installation Considerations

## Terminal Dimensions and Spacing Requirements

Use the following diagrams to make sure the Protos X system can be installed in your application. Protos X terminals require 35mm DIN rail for mounting; there are no orientation restrictions.

To ensure proper airflow for cooling purposes, units should be spaced, at a minimum, as shown. It is also important to check the Protos X dimensions against the conditions required for your application.

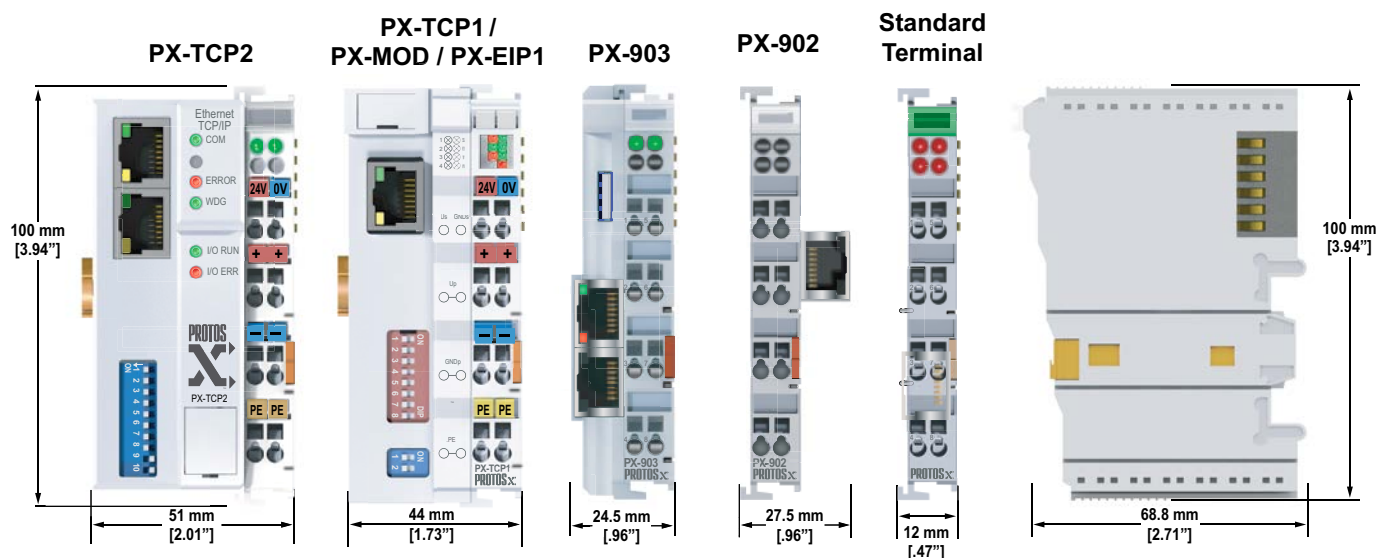
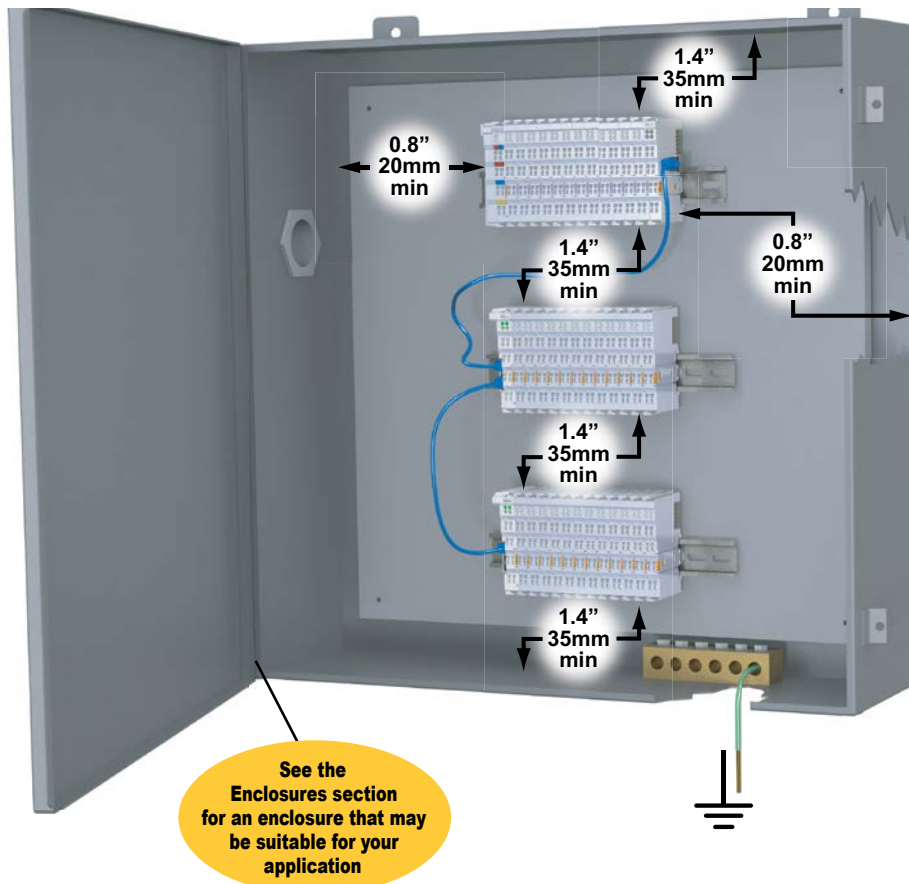

# Installation Considerations

## Terminal Types

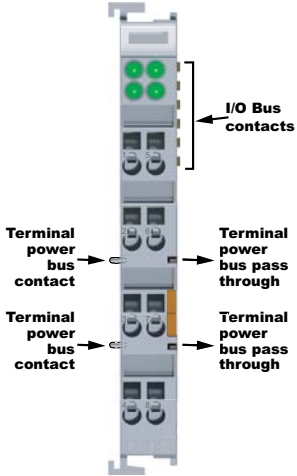
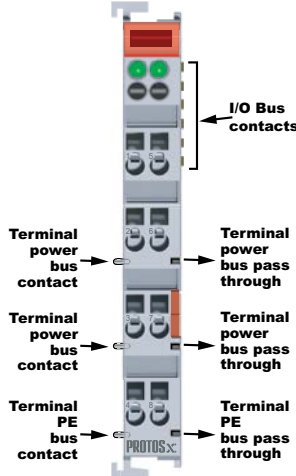
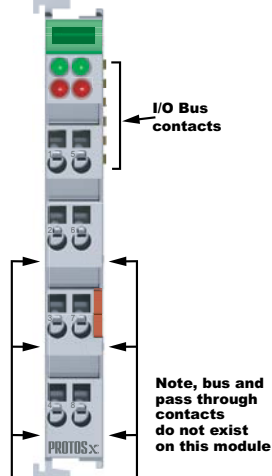
TYPE 1	TYPE 2	TYPE 3
 <p>I/O Bus contacts</p> <p>Terminal power bus contact</p> <p>Terminal power bus pass through</p> <p>Terminal power bus contact</p> <p>Terminal power bus pass through</p>	 <p>I/O Bus contacts</p> <p>Terminal power bus contact</p> <p>Terminal power bus pass through</p> <p>Terminal power bus contact</p> <p>Terminal power bus pass through</p> <p>Terminal PE bus contact</p> <p>Terminal PE bus pass through</p> <p>PROTOS<sub>x</sub></p>	 <p>I/O Bus contacts</p> <p>Note, bus and pass through contacts do not exist on this module</p> <p>PROTOS<sub>x</sub></p>
<p>Type 1: This terminal passes the terminal power bus from the preceding terminal to the next terminal and therefore it must be mounted to a preceding terminal that passes bus power.</p>	<p>Type 2: This terminal passes the terminal power bus and PE from the preceding terminal to the next terminal and therefore it must be preceded by a terminal that passes both terminal power bus and PE.</p>	<p>Type 3: This terminal does not pass the terminal power bus or PE and can be preceded by any terminal, however it will interrupt the terminal power bus and PE.</p>

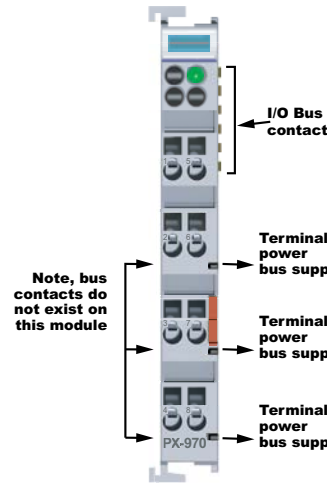
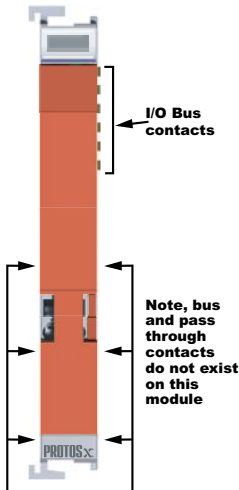
TYPE 4	TYPE 5
 <p>I/O Bus contacts</p> <p>Note, bus contacts do not exist on this module</p> <p>Terminal power bus supply</p> <p>Terminal power bus supply</p> <p>Terminal power bus supply</p> <p>PX-970</p>	 <p>I/O Bus contacts</p> <p>Note, bus and pass through contacts do not exist on this module</p> <p>PROTOS<sub>x</sub></p>
<p>Type 4: This terminal requires external voltage connection and supplies the terminal power bus to terminals located to its right. The terminals to its right must support the same power bus of 120/230 VAC or 24VDC. This terminal will not pass terminal power or PE from any preceding terminals.</p>	<p>Type 5: This terminal is used to separate the terminal power bus and PE from other terminals and can be mounted next to any terminal.</p>