

pro^{ense}® Thermocouple Heat Trace Probe with Connection Head

Overview

Heat Trace Thermocouples are used to measure the surface temperature of process pipe that is carrying products whose temperatures must be controlled to prevent freeze-up, or to maintain a viscosity level so that the inner medium will flow.



THMJ-HT34-01



Open head

- Probe
 - Type J thermocouple element
 - 1/4" diameter, 316 SS sealed sheath to protect against harsh environments
 - 3" hot leg with 1"x2" weld pad for mounting to pipe surface
 - Mounting weld pad is flexible enough to be formed around nominal pipe sizes from 1" to 12"
 - 4" cold leg allows for electrical connections outside of pipe insulation
- Connection Head
 - Cast aluminum NEMA 4X, IP66 screw cover head with captive gasket
 - One turn cover removal & installation eliminates cross threading and saves time
 - 3/4" NPT conduit opening with internal stop to prevent overtightening and installation damage
 - Gripping ribs on cover edge
 - Stainless steel cover chain
- Wiring
 - Brass terminals with stainless steel screws eliminate the need to wrap connections around screws
 - Elevated terminal block for easy wire termination
- Made in the USA

Thermocouple Heat Trace Probe with Connection Head							
Part Number	Pcs/Pkg	Wt (lb)	Price	Type	Probe Length	Temperature Sensing Range	Mounting
THMJ-HT34-01	1	1.44	\$63.00	J	3" Hot Leg / 4" Cold Leg	-18 to 482°C (0 to 900°F)	1" X 2" X R3/4" Weld Pad, 304 SS*

* Mounting pad is flexible enough to be formed around nominal pipe sizes from 1" to 12"

Technical Specifications	
Junction Type	Ungrounded
ASTM E230 Standard Limits of Error	±2.2°C (±4.0°F) or 0.75%, whichever is greater
Probe	ø1/4", 316 stainless steel sheath, single thermocouple element
Connection Head	Die-cast aluminum, screw cover with stainless steel chain, compressed graphite gasket, NEMA 4X, IP66, 3/4" NPT conduit opening, max temp. 400°F (204°C)
Response Time	2.9 seconds, 63.2% of a 25-77°C step change per method ASTM E839
Wiring	Connection head: Ceramic terminal base with brass terminals and stainless steel screws (Recommended tightening torque 3-4 lb-in)

Thermocouple extension lead wire available at www.automationdirect.com.



NOTE: CHECK THE CHEMICAL COMPATIBILITY OF THE SENSOR'S WETTED PARTS WITH THE MEDIUM TO BE MEASURED.

prosense® Thermocouple Heat Trace Probes with Connection Head

Dimensions

inches [mm]

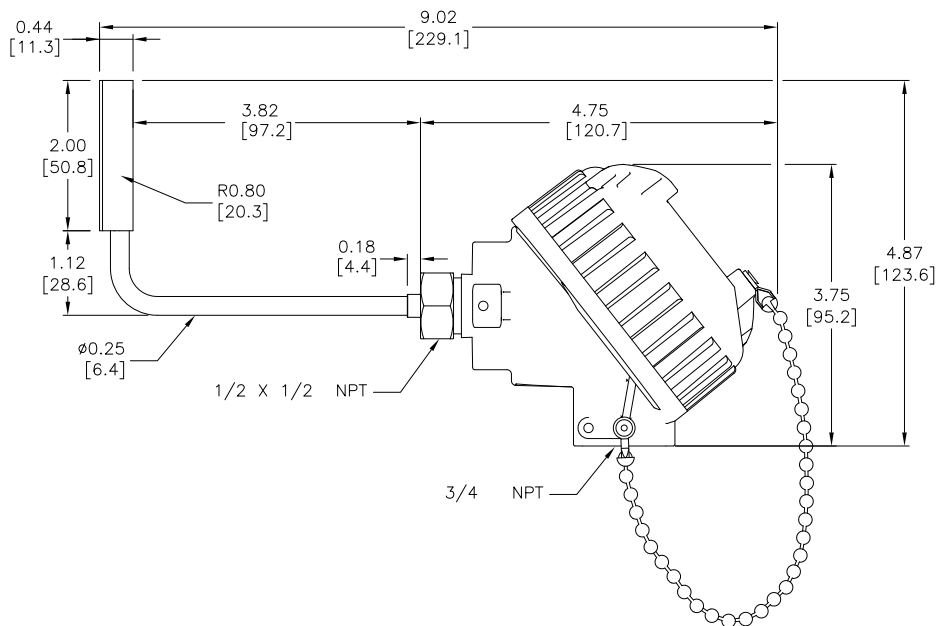

Wiring Information

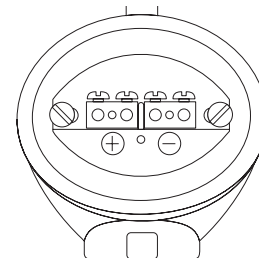

Type J: (+) white (-) red

- Must use thermocouple extension lead wire
- Observe polarity when making connections
- Do not use standard wire nuts
- Recommended screw terminal tightening torque 3-4 lb-in

