

proSense® PPC5 Advanced Process Controller

Overview:



PPC5 Series

Made exclusively for AutomationDirect by Yokogawa, the ProSense PPC5 series of Advanced Process Controllers is loaded with the features, functionality, and powerful performance to handle temperature, pressure, level, flow, and other process variable control applications. These controllers accept inputs directly from thermocouples or RTD's and analog signals from most any type of process variable sensor/transmitter. Models are available with an additional analog input for remote setpoint and up to 4 contact inputs that can be selected to perform up to 17 different functions. The control output is user selected to be a relay, voltage pulse, or linear current output. Also included is an analog retransmission output that is selectable to represent the PV, SP, target SP, remote SP, or output signal. When not used for retransmission, this output can be used as a loop power supply to power sensor/transmitters. Three alarm contact outputs can be configured for 30 alarm types and 10 alarm functions. The PPC5 series can be ordered without any communications, with RS-485 Modbus ASCII/RTU communications, or with Ethernet+RS-485 gateway Modbus TCP/IP communications. The controllers can be configured using the keypad and large 5-digit multicolor display or using free downloadable software.

Features:

- **Process variable input:** thermocouple (14 types), RTD (2 types), analog mA, mV, V (8 ranges)
- **Remote setpoint analog input:** V (5 ranges) PPC5-11xx models only
- **Control period:** 50ms, 100ms, or 200ms selectable
- **Contact inputs:** 3 (PPC5-10xx), 4 (PPC5-11xx), 17 selectable functions
- **Control output:** selectable relay, voltage pulse, or linear current
- **Retransmission output:** mA selectable for PV, SP, target SP, remote SP, or output
- **Transmitter loop power supply:** 15V available when not using retransmission output
- **Alarm outputs:** 3 alarm contacts, selectable 30 alarm types and 10 alarm functions
- **Communications:** Models without communications, RS-485, Modbus slave ASCII / RTU, Coordinated communication, or Ethernet+RS-485 gateway, Modbus TCP/IP
- **Configuration:** Keypad or free downloadable software
- **User Function Keys:** 3 on the keypad, 22 selectable functions
- **Display:** Large 5-digit LCD, PV line-white/red (color changing), Data line-orange, 2 selectable bar graphs orange and white
- **Agency Compliance & Certifications:** UL Recognized, CSA, CE
- **Warranty:** 3 years



Control Modes

All Models

- Single-loop control
- Loop control with PV-hold function

Models with Auxiliary Analog Input

- Cascade primary-loop control
- Cascade secondary-loop control
- Cascade control (single controller)
- Loop control for backup
- Loop control with PV switching
- Loop control with PV auto-selector

Control Types

- PID Control (8 parameter groups)
- ON/OFF Control (1 point of hysteresis)
- ON/OFF Control (2 points of hysteresis)
- Sample PI control
- Batch PID control
- Manual control

Alarm Types

- PV (measured value) high/low limit alarm
- Deviation high/low limit alarm
- Deviation high and low limits alarm
- Deviation within high and low limits alarm
- Analog input PV high/low limit alarm
- Analog input REMOTE SP high/low limit alarm
- PV rate-of-change alarm
- SP (setpoint) high/low limit alarm
- Target SP high/low limit alarm
- Target SP deviation high/low limit alarm
- Target SP deviation high and low limits alarm
- Target SP deviation within high and low limits alarm
- Control output high/low limit alarm
- Self-diagnosis alarm
- FAIL

Alarm Functions

- Hysteresis
- Stand-by
- Latch (4 types)
- Release of Alarm Latch
- Delay Timer
- Energized/De-energized
- PV Velocity

proSense® PPC5 Advanced Process Controller

Contact Input Functions

- AUTO/MANUAL switching
- REMOTE/LOCAL switching
- STOP/START switching
- Switching to CASCADE
- Switching to AUTO
- Switching to MANUAL
- Switching to REMOTE
- Switching to LOCAL
- AUTO-TUNING START/STOP switching
- OUTPUT TRACKING switching
- Two-input switching
- PV Hold
- LCD backlight ON/OFF switching
- Message interrupt displays 1 through 4
- SP number specification
- PID number specification
- Manual preset output number specification

User Function Key Functions

- Off
- AUTO/MANUAL switch
- CASCADE/AUTO/MAN switch
- REMOTE/LOCAL switch
- Loop-2 REMOTE/LOCAL switch
- STOP/RUN switch
- Switch to CASCADE
- Switch to AUTO
- Switch to MANUAL
- Switch to REMOTE
- Switch to LOCAL
- Switch to Loop-2 REMOTE
- Switch to Loop-2 LOCAL
- Switch to STOP
- Switch to RUN
- Auto-tuning switch
- LCD brightness UP
- LCD brightness DOWN
- Adjust LCD brightness
- LCD Backlight ON/OFF switch
- Latch release
- PID Tuning switch

Other Available Functions

- Selectable action on PV burnout detection
- Internal or external thermocouple reference junction compensation
- Analog input square root extraction
- Input and output 10 segment linearization
- Auto-selector between larger, smaller, average, or difference of two PV inputs
- Switch between PV inputs based on low/high limit or percentage values or contact input
- Switch between PID groups based on setpoint, target setpoint, PV, deviation, or contact input
- Overshoot suppression “Super” function
- Hunting suppression “Super2” function
- Integral action suppression (anti-reset wind-up)
- Output velocity limiter
- Output tight shut function
- Non-linear PID control
- Auto-tuning speed adjustment
- Selectable SP ramp rate
- SP tracking of PV or remote SP functions
- Selectable restart mode and timer
- Split Computation Output

PPC5 Advanced Process Controller Selection						
Model	Description	Retransmission Output	Auxiliary Analog Input	Communications	Weight (lbs)	Price
PPC5-1000	ProSense advanced process controller, 1/4 DIN, 2-line alpha-numeric LCD, bar graph LCD, current, voltage, RTD, thermocouple, discrete input, current, voltage pulse, relay output, 100-240 VAC operating voltage.	Yes	No	No	1.15	\$325.00
PPC5-1001				RS-485	1.19	\$385.00
PPC5-1002				Ethernet	1.21	\$415.00
PPC5-1100			Yes	No	1.19	\$380.00
PPC5-1101				RS-485	1.23	\$440.00
PPC5-1102				Ethernet	1.25	\$470.00

proSense® PPC5 Advanced Process Controller

PPC5 Technical Specifications	
Input Power Requirements	100-240 VAC (+10%/-15%), 50/60 Hz
Power Consumption	18 VA
Isolation	Between primary terminals and secondary terminals: 2300VAC for 1 minute (UL, CSA) Between primary terminals and secondary terminals: 3000VAC for 1 minute (CE) Between primary terminals: 1500VAC for 1 minute (Power and relay output terminals) Between secondary terminals: 500VAC for 1 minute (Analog I/O signal terminals, contact input terminals, communication terminals and functional grounding terminals)
Insulation	Between power supply terminals and grounding terminal 20M Ω or more at 500VDC
Control Types	PID (Reverse and Direct acting), ON/OFF (1 or 2 point hysteresis), Sample PI control, and Batch PID
Continuous Vibration	At 5 to 9 Hz: Half amplitude of 1.5 mm or less, 1oct/min for 90 minutes each in the three axis directions At 9 to 150 Hz: 4.9 m/s ² or less, 1oct/min for 90 minutes each in the three axis directions
Shock	98 m/s ² or less, 11 ms
Shock-period Vibration	14.7 m/s ² , 15 seconds or less
Magnetic Field	400 A/m or less
Ambient Temperature Range	-10 to 50°C (side-by-side mounting: -10 to 40 °C)
Ambient Humidity	20 to 90% RH (no condensation allowed)
Storage Temperature	-25 to 70°C
Storage Temperature Change	20°C/h or less
Storage Humidity	5 to 95% RH (no condensation allowed)
Altitude	2000m or less above sea level
Startup Time	10 seconds or less
Warm-up Time	30 minutes or more after power on
Ambient Temperature Effect	Voltage or TC input: $\pm 1 \mu\text{V}/^\circ\text{C}$ or $\pm 0.01\%$ of F.S./ $^\circ\text{C}$, whichever is larger Current input: $\pm 0.01\%$ of F.S./ $^\circ\text{C}$ RTD input: $\pm 0.05^\circ\text{C}/^\circ\text{C}$ (ambient temperature) or less Analog output: $\pm 0.02\%$ of F.S./ $^\circ\text{C}$ or less
Power Supply Voltage Effect	Analog input: $\pm 0.05\%$ of F.S. or less (Within rated voltage range) Analog output: $\pm 0.05\%$ of F.S. or less (Within rated voltage range)
Configuration Cable and IR Adapter (PPC5-CBL1)	USB to maintenance port cable (PPC5 powered through cable) or IR front panel adapter (Powered PPC5) for installed unit (Compatible with all models including PPC5-1x00 without communication) Rated USB input voltage: 4.75 to 5.25 VDC at 100mA DC (including the cable) Dust- and drip-proof: IP3x
RS-485 Communication (PPC5-1x01 Models)	RS-485 (PPC-1x01 models) Modbus (ASCII/RTU) and coordinated control 4-wire type half-duplex or 2-wire type half-duplex, asynchronous operation, non-procedural Max nodes: 31 Max communication distance: 1200m Baud rate: 600, 1200, 2400, 4800, 9600, 19200, 38400 bps
Ethernet Communication (PPC5-1x02 Models)	Ethernet (PPC-1x02 models) Modbus/TCP w/ RS-485 serial gateway RJ45 (10BASE-T/100BASE-TX) Maximum connections: 2 Max communication distance: 100m Default port #: 502 (Selectable range 1024 to 65535) Serial gateway: RS-485 2-wire half-duplex, Modbus/RTU (9600, 19200, or 38400 bps)
IP Rating	IP66 (Front panel when installed)
Agency Compliance & Certifications	UL Recognized (file # E311366), CSA (file # 600893), CE
Installation Category	II
Measurement Category	I (CAT I) (UL, CSA), 0 (Other) (CE)
Pollution Degree	Degree 2

pro^{sense} PPC5 Advanced Process Controller

PPC5 Technical Specifications					
Input					
PV (Universal Input)					
Number of Inputs		1			
Input Type		Instrument Range		Accuracy	
		°C	°F		
Thermocouple	K	-270.0 to 1370.0°C	-450.0 to 2500.0°F	±0.1% of instrument range ±1 digit for 0°C or more ±0.2% of instrument range ±1 digit for less than 0°C ±2% of instrument range ±1 digit for less than -200.0°C of thermocouple K ±1% of instrument range ±1 digit for less than -200.0°C of thermocouple T	
		-270.0 to 1000.0°C	-450.0 to 2300.0°F		
		-200.0 to 500.0°C	-200.0 to 1000.0°F		
	J	-200.0 to 1200.0°C	-300.0 to 2300.0°F		
		-270.0 to 400.0°C	-450.0 to 750.0°F		
	T	0.0 to 400.0°C	-200.0 to 750.0°F		
		0.0 to 1800.0°C	32 to 3300°F		±0.15% of instrument range ±1 digit for 400°C or more ±5% of instrument range ±1 digit for less than 400°C
	B	0.0 to 1700.0°C	32 to 3100°F		±0.15% of instrument range ±1 digit
	S	0.0 to 1700.0°C	32 to 3100°F		
	R	-200.0 to 1300.0°C	-300.0 to 2400.0°F		±0.1% of instrument range ±1 digit ±0.25% of instrument range ±1 digit for less than 0°C
	N	-270.0 to 1000.0°C	-450.0 to 1800.0°F		±0.1% of instrument range ±1 digit for 0°C or more ±0.2% of instrument range ±1 digit for less than 0°C ±1.5% of instrument range ±1 digit for less than -200.0°C of thermocouple E.
	E	-200.0 to 900.0°C	-300.0 to 1600.0°F		
	L	-200.0 to 400.0°C	-300.0 to 750.0°F		
		0.0 to 400.0°C	-200.0 to 1000.0°F		
	U	0.0 to 2300.0°C	32 to 4200°F		±0.2% of instrument range ±1 digit (Note 2)
W	0.0 to 1390.0°C	32.0 to 2500.0°F	±0.1% of instrument range ±1 digit		
Platinel 2	0.0 to 1900.0°C	32 to 3400°F	±0.5% of instrument range ±1 digit for 800°C or more Accuracy is not guaranteed for less than 800°C		
PR20-40	0.0 to 2000.0°C	32 to 3600°F	±0.2% of instrument range ±1 digit		
W97Re3-W75Re25					
RTD	JPt100	-200.0 to 500.0°C	-300.0 to 1000.0°F	±0.1% of instrument range ±1 digit (Note 1)	
		-150.00 to 150.00°C	-200.0 to 300.0°F	±0.1% of instrument range ±1 digit	
	Pt100	-200.0 to 850.0°C	-300.0 to 1560.0°F	±0.1% of instrument range ±1 digit (Note 1)	
		-200.0 to 500.0°C	-300.0 to 1000.0°F		
		-150.00 to 150.00°C	-200.0 to 300.0°F		
Standard Signal	0.400 to 2.000 V		±0.1% of instrument range ±1 digit		
	1.000 to 5.000 V				
	4.00 to 20.00 mA				
	0.000 to 2.000 V				
	0.00 to 10.00 V				
	0.00 to 20.00 mA				
	-10.00 to 20.00 mV				
DC Voltage/Current	0.0 to 100.0 mV				

The accuracy is that in the standard operating conditions: 23±2°C, 55±10%RH, and power frequency at 50/60 Hz.

Note 1: ±0.3°C ±1 digit in the range between 0 and 100°C, ±0.5°C ±1 digit in the range between -100 and 200°C.

Note 2: W: W-5% Re/W-26% Re(Hoskins Mfg.Co.). ASTM E988

pro^sense® PPC5 Advanced Process Controller

PPC5 Technical Specifications		
Remote Auxiliary Analog Input (RSP) (PPC5-11xx models)		
Number of Inputs	1	
Input Type	Instrument Range	Accuracy
Standard Signal	0.400 to 2.000 V	±0.2% of instrument range ±1 digit
	1.000 to 5.000 V	±0.1% of instrument range ±1 digit
DC Voltage	0.000 to 2.000 V	±0.2% of instrument range ±1 digit
	0.00 to 10.00 V	±0.1% of instrument range ±1 digit
DC Voltage for High-Input Impedance	0.000 to 1.250 V	±0.1% of instrument range ±1 digit
Digital Inputs		
Number of Inputs	3 (PPC5-10xx) or 4 (PPC5-11xx)	
Type	Dry contact or NPN transistor input	
Contact Rating	12VDC, 10mA or more (Use a contact with a minimum on-current of 1mA or less)	
ON/OFF Detection	Dry contact input: Contact resistance of 1k Ω or less is determined as "ON" and contact resistance of 50k Ω or more as "OFF". NPN Transistor input: Input voltage of 2V or less is determined as "ON" and leakage current must not exceed 100 μ A when "OFF".	
Minimum Detection Hold Time	Control period +50 ms	
Output		
Analog Control Output		
Number of Outputs	1 (Current or Pulsed Voltage)	
Current Output	4 to 20 mA DC or 0 to 20 mA DC/load resistance of 600 Ω or less	
Current Accuracy	±0.1% of span (±5% of span for 1mA or less) in the standard operating conditions: 23±2°C, 55±10%RH and power frequency at 50/60 Hz	
Voltage Pulse Output	Time proportional output (On-voltage: 12V or more/load resistance of 600 Ω or more / Off-voltage: 0.1 V DC or less)	
Voltage Pulse Resolution	10ms or 0.1% of output, whichever is larger	
Relay Control Output		
Number of Outputs	1	
Contact Type	SPDT (Form C)	
Contact Rating	250VAC, 3A max., 10mA min. or 30VDC, 3A max., 10mA min. (resistance load)	
Relay Alarm Output		
Number of Outputs	3	
Contact Type	SPST N.O. (Form A), (Independent commons)	
Contact Rating	240VAC, 1A max., 1mA min. or 30VDC, 1A max., 1mA min. (resistance load)	
Retransmission Output		
Number of Outputs	1 (Or output can be substituted for 15VDC Loop Power Supply)	
Current Output	4 to 20 mA DC or 0 to 20 mA DC/ load resistance of 600 Ω or less	
Current Accuracy	±0.1% of span (±5% of span for 1 mA or less) in the standard operating conditions: 23±2°C, 55±10%RH and power frequency at 50/60 Hz (Output accuracy only not combined input to output)	
Loop Power Supply	14.5 to 18.0 VDC	
Supply Current	Approximately 21mA maximum (Short-circuit current limiting circuit)	

prosense[®] PPC5 Advanced Process Controller

Wiring

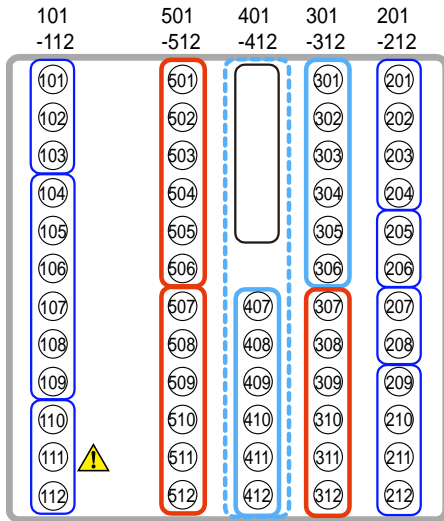

Control output OUT

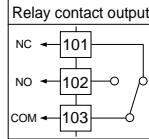

Contact output ALM

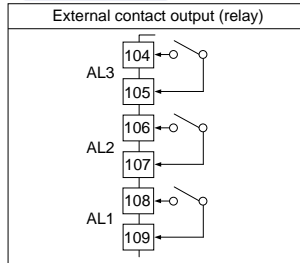

PV input PV

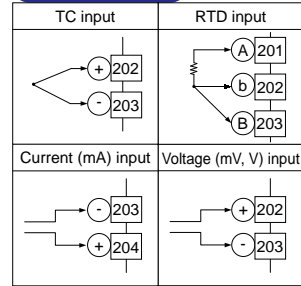

Retransmission output RET

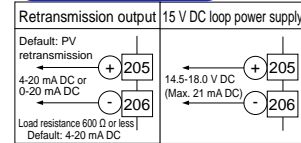

Ethernet communication (with gateway function)

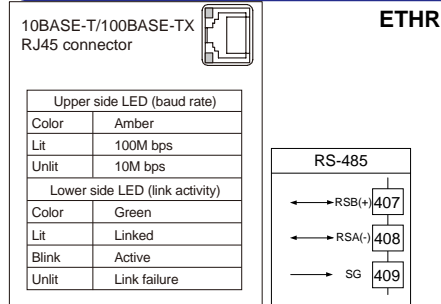

Power supply

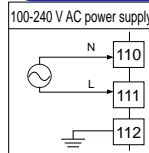

Control output OUT

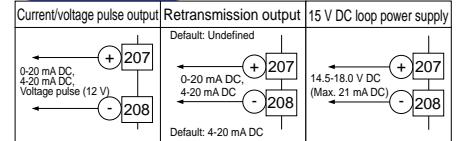

Aux. analog input / Contact input RSP

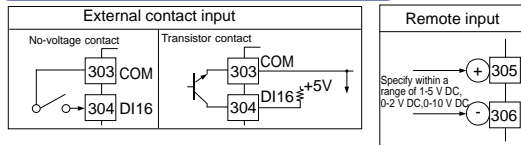

RS-485 communication

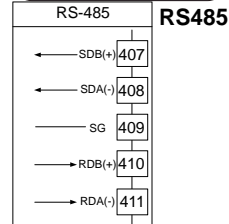

Contact input DI

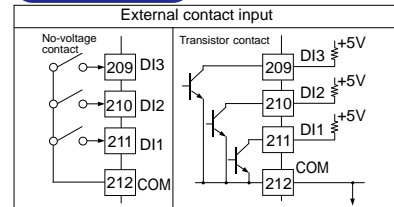

prosense® PPC5 Advanced Process Controller

Dimensions

mm [inches]

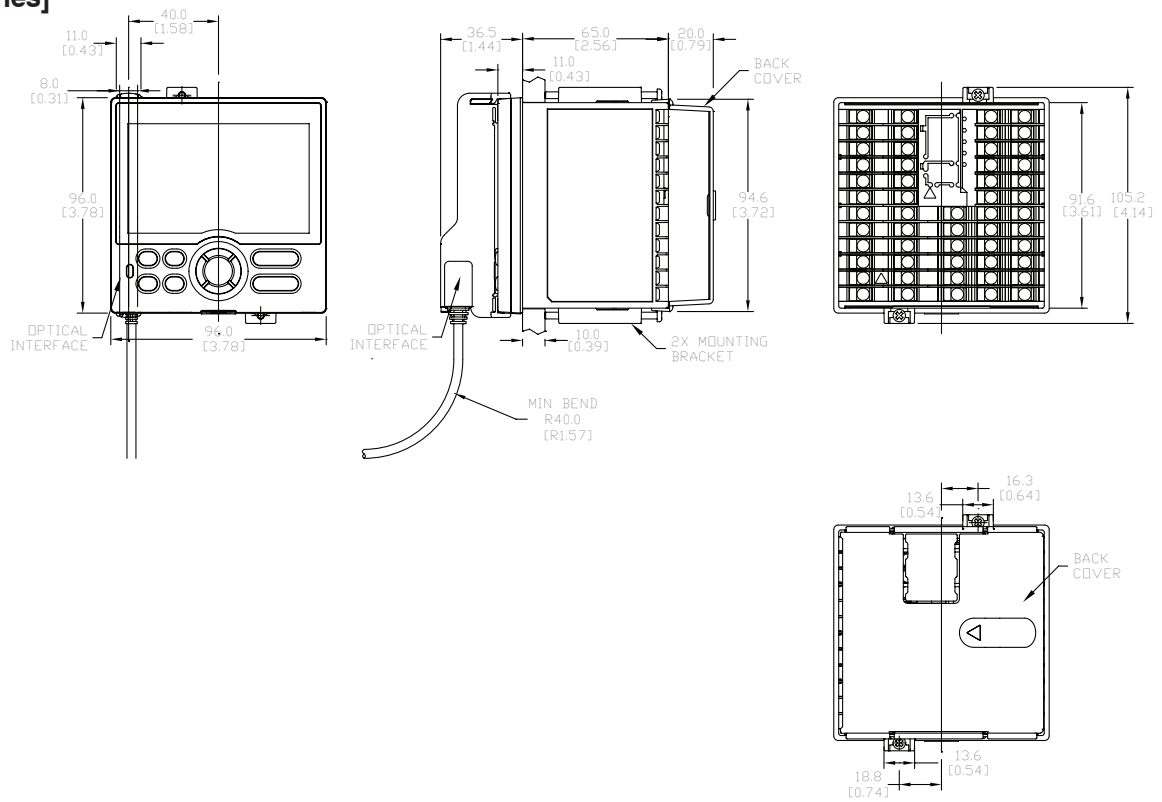

See our website www.AutomationDirect.com for complete Engineering drawings.

Insert



Scan or click the above QR code to be taken to the PPC5 Series Installation Instructions and User Guide

Manual



Scan or click the above QR code to be taken to the PPC5 Series User Manual

proSense® PPC5 Advanced Process Controller Accessories



The ProSense PPC5-CBL1 is required to configure a PPC5-1x00 advanced process controller without RS-485 or Ethernet communications via a computer running the Parameter Setting Software (free download from www.automationdirect.com).

PPC5 series controller models with RS-485 (PPC5-1x01) or Ethernet (PPC5-1x02) communications can be configured using the PPC5-CBL1 or via the controller's communication RS-485 terminals or Ethernet port.

All PPC5 series controllers can be configured using the controller's keypad and display.

PPC5 Advanced Process Controller Accessories			
Model	Description	Weight (lbs)	Price
PPC5-CBL1	ProSense configuration cable, USB to micro-USB and IR adapter. For use with all PPC5 Series advanced process controllers.	0.6	\$175.00
USB-485M	USB to RS-485 adapter. For use with PPC5-1x01 advanced process controllers.	0.40	\$55.00

Parameter Setting Software available for free download from www.automationdirect.com

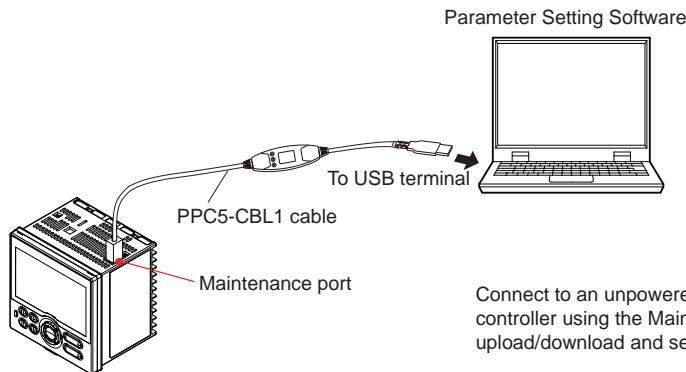

Connect to an unpowered PPC5 series controller using the Maintenance Port to upload/download and set parameters.

When using the maintenance port, power is provided from the USB port. Do not supply power to the controller through the terminals until disconnected from the maintenance port.

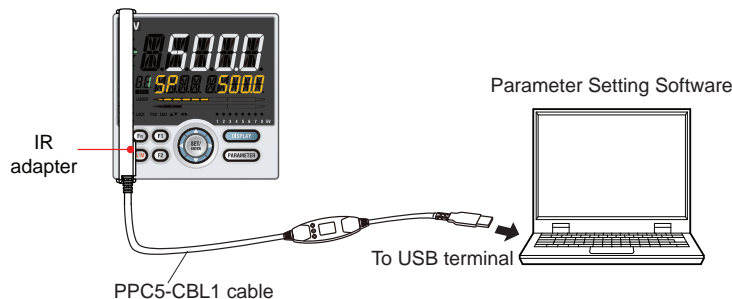

Connect to a powered PPC5 series controller using the IR adapter to upload/download and set parameters, monitor operations, tune control loops, and file management.

The IR adapter does not power the controller. When using the IR adapter power must be supplied to the controller.