

proSense® EPS Series (-1001) Digital Pressure Sensors



Features

- Ideal for industrial pressure measurement and indication in both gas and liquid applications
- Measuring ranges from vacuum up to 5800 psig
- Selectable engineering units include psig, bar, mbar, kPa, MPa, inH₂O, and inHg
- 1/4" NPT male process connection allows for direct installation without requiring extra fittings
- 2 solid state switch outputs provide a reliable alternative to mechanical pressure switches
- Output 2 can be configured as a scalable analog signal turning the unit into a combination pressure switch and transmitter
- Built-in two-color 4-digit display is easy to read from a distance and provides indication of measured pressure and switch setpoints
- Display can be set to change color between red and green based on measured value or output status and rotated 180° for installation flexibility
- 2 large bright LEDs indicate output status
- Sensor housing can be rotated 345° for optimum visibility after installation
- Simple pushbutton setup for easy and quick configuration prior to installation without the need for a separate pressure reference gauge
- Stainless steel housing allows for a high IP67 ingress protection rating
- 4-pin M12 electrical connection
- Protective cover and mounting bracket are available accessories
- Compact and robust design and construction withstands extreme shock and vibration, provides high accuracy and reliability, and incorporates the best combination of over pressure, burst pressure and long term stability for each measuring range
- 3-year warranty



EPS Series (-1001) Digital Pressure Sensors

Part Number	Description	Pcs/Pkg	Wt (lb)	Price
<u>EPS25-V14-1001</u>	ProSense digital pressure sensor, -14.5 to 14.5 psig range, output 1: switch (N.O./N.C.), PNP/NPN selectable, output 2: switch (N.O./N.C.), PNP/NPN selectable or 4-20 mA/0-10 VDC, 1/4in male NPT process connection, 4-pin M12 quick-disconnect, 18-30 VDC operating voltage, 4-digit, two-color LED display, for use with compatible liquids or gases. Purchase cable separately.	1	0.5	\$288.00
<u>EPS25-100WC-1001</u>	ProSense digital pressure sensor, -5 to 100.4 inches of water column range, output 1: switch (N.O./N.C.), PNP/NPN selectable, output 2: switch (N.O./N.C.), PNP/NPN selectable or 4-20 mA/0-10 VDC, 1/4in male NPT process connection, 4-pin M12 quick-disconnect, 18-30 VDC operating voltage, 4-digit, two-color LED display, for use with compatible liquids or gases. Purchase cable separately.	1	0.5	\$288.00
<u>EPS25-14-1001</u>	ProSense digital pressure sensor, -0.72 to 14.5 psig range, output 1: switch (N.O./N.C.), PNP/NPN selectable, output 2: switch (N.O./N.C.), PNP/NPN selectable or 4-20 mA/0-10 VDC, 1/4in male NPT process connection, 4-pin M12 quick-disconnect, 18-30 VDC operating voltage, 4-digit, two-color LED display, for use with compatible liquids or gases. Purchase cable separately.	1	0.5	\$288.00
<u>EPS25-36-1001</u>	ProSense digital pressure sensor, -1.8 to 36.25 psig range, output 1: switch (N.O./N.C.), PNP/NPN selectable, output 2: switch (N.O./N.C.), PNP/NPN selectable or 4-20 mA/0-10 VDC, 1/4in male NPT process connection, 4-pin M12 quick-disconnect, 18-30 VDC operating voltage, 4-digit, two-color LED display, for use with compatible liquids or gases. Purchase cable separately.	1	0.5	\$288.00
<u>EPS25-V145-1001*</u>	ProSense digital pressure sensor, -14.6 to 145 psig range, output 1: switch (N.O./N.C.), PNP/NPN selectable, output 2: switch (N.O./N.C.), PNP/NPN selectable or 4-20 mA/0-10 VDC, 1/4in male NPT process connection, 4-pin M12 quick-disconnect, 18-30 VDC operating voltage, 4-digit, two-color LED display, for use with compatible liquids or gases. Purchase cable separately.	1	0.5	\$288.00
<u>EPS25-360-1001*</u>	ProSense digital pressure sensor, -14.5 to 362.5 psig range, output 1: switch (N.O./N.C.), PNP/NPN selectable, output 2: switch (N.O./N.C.), PNP/NPN selectable or 4-20 mA/0-10 VDC, 1/4in male NPT process connection, 4-pin M12 quick-disconnect, 18-30 VDC operating voltage, 4-digit, two-color LED display, for use with compatible liquids or gases. Purchase cable separately.	1	0.5	\$288.00
<u>EPS25-1450-1001*</u>	ProSense digital pressure sensor, 0 to 1450 psig range, output 1: switch (N.O./N.C.), PNP/NPN selectable, output 2: switch (N.O./N.C.), PNP/NPN selectable or 4-20 mA/0-10 VDC, 1/4in male NPT process connection, 4-pin M12 quick-disconnect, 18-30 VDC operating voltage, 4-digit, two-color LED display, for use with compatible liquids or gases. Purchase cable separately.	1	0.5	\$288.00
<u>EPS25-3620-1001</u>	ProSense digital pressure sensor, 0 to 3625 psig range, output 1: switch (N.O./N.C.), PNP/NPN selectable, output 2: switch (N.O./N.C.), PNP/NPN selectable or 4-20 mA/0-10 VDC, 1/4in male NPT process connection, 4-pin M12 quick-disconnect, 18-30 VDC operating voltage, 4-digit, two-color LED display, for use with compatible liquids or gases. Purchase cable separately.	1	0.5	\$288.00
<u>EPS25-5800-1001</u>	ProSense digital pressure sensor, 0 to 5800 psig range, output 1: switch (N.O./N.C.), PNP/NPN selectable, output 2: switch (N.O./N.C.), PNP/NPN selectable or 4-20 mA/0-10 VDC, 1/4in male NPT process connection, 4-pin M12 quick-disconnect, 18-30 VDC operating voltage, 4-digit, two-color LED display, for use with compatible liquids or gases. Purchase cable separately.	1	0.5	\$288.00

* For gas applications 362 psig (25bar) maximum pressure!



NOTE: CHECK THE CHEMICAL COMPATIBILITY OF THE SENSOR'S WETTED PARTS WITH THE MEDIUM TO BE MEASURED

prosense® EPS Series (-1001) Digital Pressure Sensors

EPS Series (-1001) Digital Pressure Sensors									
Part Number	Measuring Range	Setting Range Set Point, SP	Reset Point, rP	Analog Start Point, ASP	Analog End Point, AEP	Steps	Proof Pressure	Bursting Pressure	Vacuum Resistance
<u>EPS25-V14-1001</u>	-14.5 to 14.5 psig -1000 to 1000 mbar -100 to 100 kPa -402 to 402 inH2O -29.5 to 29.5 inHg	-14.3 to 14.5 psig -985 to 1000 mbar -98.5 to 100 kPa -396 to 402 inH2O -29.2 to 29.5 inHg	-14.45 to 14.4 psig -995 to 990 mbar -99.5 to 99 kPa -400 to 398 inH2O -29.4 to 29.3 inHg	-14.5 to 8.7 psig -1000 to 600 mbar -100 to 60 kPa -402 to 240 inH2O -29.5 to 17.7 inHg	-8.7 to 14.5 psig -600 to 1000 mbar -60 to 100 kPa -240 to 402 inH2O -17.7 to 29.5 inHg	0.05 psig 5 mbar 0.5 kPa 2 inH2O 0.1 inHg	290 psig 20000 mbar 2000 kPa 8030 inH2O 590 inHg	725 psig 50000 mbar 5000 kPa 20068 inH2O 1476 inHg	-14.5 psig -1000 mbar
<u>EPS25-100WC-1001</u>	-5 to 100.4 inH2O -12.5 to 250 mbar -1.25 to 25 kPa -125 to 2550 mmWS	-4.4 to 100.4 inH2O -11 to 250 mbar -1.1 to 25 kPa -110 to 2550 mmWS	-4.8 to 100 inH2O -12 to 249 mbar -1.2 to 24.9 kPa -120 to 2540 mmWS	-5 to 80.2 inH2O -12.5 to 200 mbar -1.25 to 20 kPa -125 to 2040 mmWS	15 to 100.4 inH2O 37.5 to 250 mbar 3.75 to 25 kPa 385 to 2550 mmWS	0.2 inH2O 0.5 mbar 0.05 kPa 5mmWS	2400 inH2O 6000 mbar 600 kPa 61000 mmWS	12000 inH2O 30000 mbar 3000 kPa 306000 mmWS	-120 inH2O -300 mbar
<u>EPS25-14-1001</u>	-0.72 to 14.50 psig -50 to 1000 mbar -5 to 100 kPa -20 to 401.5 inH2O	-0.64 to 14.5 psig -44 to 1000 mbar -4.4 to 100 kPa -17.5 to 401.5 inH2O	-0.7 to 14.44 psig -48 to 996 mbar -4.8 to 99.6 kPa -19 to 400 inH2O	-0.72 to 11.6 psig -50 to 800 mbar -5 to 80 kPa -20 to 321 inH2O	2.18 to 14.5 psig 150 to 1000 mbar 15 to 100 kPa 60.5 to 401.5 inH2O	0.02 psig 2 mbar 0.2 kPa 0.5 inH2O	145 psig 10000 mbar 1000 kPa 4000 inH2O	450 psig 30000 mbar 3000 kPa 12040 inH2O	
<u>EPS25-36-1001</u>	-1.8 to 36.25 psig -0.125 to 2.5 bar -12.5 to 250 kPa	-1.6 to 36.25 psig -0.11 to 2.5 bar -11 to 250 kPa	-1.75 to 36.1 psig -0.12 to 2.49 bar -12 to 249 kPa	-1.8 to 29.0 psig -0.125 to 2.0 bar -12.5 to 200 kPa	5.45 to 36.25 psig 0.375 to 2.5 bar 37.5 to 250 kPa	0.05 psig 0.005 bar 0.5 kPa	290 psig 20 bar 2000 kPa	725 psig 50 bar 5000 kPa	
<u>EPS25-V145-1001*</u>	-14.6 to 145 psig -1 to 10 bar -0.1 to 1 MPa	-13.6 to 145 psig -0.94 to 10 bar -0.094 to 1 MPa	-14.2 to 144.4 psig -0.98 to 9.96 bar -0.098 to 0.996 MPa	-14.6 to 116 psig -1 to 8 bar -0.1 to 0.8 MPa	14.6 to 145 psig 1 to 10 bar 0.1 to 1 MPa	0.2 psig 0.02 bar 0.002 MPa	1087 psig 75 bar 7.5 MPa	2715 psig 150 bar 15 MPa	
<u>EPS25-360-1001*</u>	-14.5 to 362.5 psig -1 to 25 bar -0.1 to 2.5 MPa	-12 to 362.5 psig -0.85 to 25 bar -0.085 to 2.5 MPa	-13.5 to 361 psig -0.95 to 24.9 bar -0.095 to 2.49 MPa	-14.5 to 290 psig -1 to 20 bar -0.1 to 2 MPa	58 to 362.5 psig 4 to 25 bar 0.4 to 2.5 MPa	0.5 psig 0.05 bar 0.005 MPa	2175 psig 150 bar 15 MPa	5075 psig 350 bar 35MPa	-14.5 psig -1000 mbar
<u>EPS25-1450-1001*</u>	0 to 1450 psig 0 to 100 bar 0 to 10 MPa	10 to 1450 psig 0.6 to 100 bar 0.06 to 10 MPa	4 to 1444 psig 0.2 to 99.6 bar 0.02 to 9.96 MPa	0 to 1160 psig 0 to 80 bar 0 to 8 MPa	290 to 1450 psig 20 to 100 bar 2 to 10 MPa	2 psig 0.2 bar 0.02 MPa	4350 psig 300 bar 30 MPa	9400 psig 650 bar 65 MPa	
<u>EPS25-3620-1001</u>	0 to 3625 psig 0 to 250 bar 0 to 25 MPa	25 to 3625 psig 1.5 to 250 bar 0.15 to 25 MPa	10 to 3610 psig 0.5 to 249 bar 0.05 to 24.9 MPa	0 to 2900 psig 0 to 200 bar 0 to 20 MPa	725 to 3625 psig 50 to 250 bar 5 to 25 MPa	5 psig 0.5 bar 0.05 MPa	7250 psig 500 bar 50 MPa	17400 psig 1200 bar 120 MPa	
<u>EPS25-5800-1001</u>	0 to 5800 psig 0 to 400 bar 0 to 40 MPa	40 to 5800 psig 2.5 to 400 bar 0.25 to 40 MPa	10 to 5780 psig 1 to 398.5 bar 0.1 to 39.85 MPa	0 to 4640 psig 0 to 320 bar 0 to 32 MPa	1160 to 5800 psig 80 to 400 bar 8 to 40 MPa	10 psig 0.5 bar 0.05 MPa	11580 psig 800 bar 80 MPa	24650 psig 1700 bar 170 MPa	

inH2O = Inches of Water Column

* For gas applications 362 psig (25 bar) maximum pressure!



WARNING! AVOID STATIC AND DYNAMIC OVERPRESSURE EXCEEDING THE SPECIFIED PROOF PRESSURE. EXCEEDING THE BURSTING PRESSURE FOR EVEN A SHORT TIME CAN CAUSE DESTRUCTION OF THE UNIT AND POSSIBLE INJURIES!

ProSense® EPS Series (-1001) Digital Pressure Sensors

ProSense EPS (-1001) Series General Specifications	
Electrical	
Operating Voltage¹	18 to 30 VDC
Current Consumption	< 35mA
Insulation Resistance	> 100M Ω (500VDC)
IEC Protection Class	Class III
Reverse Polarity Protection	yes
Outputs	
OUT1	switch
OUT2	switch or analog
Switch Outputs	
Type	PNP or NPN selectable
Action	N.O. or N.C. selectable
Current Rating	250mA resistive
Voltage Drop	< 2V
Short Circuit Protection	Yes (non-latching)
Overload Protection	Yes
Switching Frequency	\leq 500Hz
Function	Hysteresis or window
Analog Output	
Type	4-20 mA or 0-10 VDC selectable
Load	500 Ω max (4-20 mA), 2000 Ω min (0-10VDC)
Accuracy / Deviations (in % of the span) Turn down 1:1	
Switch Point Accuracy	< \pm 0.4% of the span
Characteristics Deviation*	< \pm 0.25 (BFSL) / < \pm 0.5 (LS)
Hysteresis	< \pm 0.1
Repeatability**	< \pm 0.1
Long-term Stability***	< \pm 0.05
Temperature Coefficients (TEMPCO) in the temperature range -25 to 80°C (in % of the span per 10°C)	
Greatest TEMPCO of the zero point	0.2
Greatest TEMPCO of the span	0.2
Reaction Times	
Power-on Delay Time	0.3 s
Min. Response Time Switching Output	< 1.5 ms
Delay Time Programmable (dS, dr)	0 to 50s
Damping for the Switching Output (dAP)	0 to 4s
Damping for the Analog Output (dAA)	0 to 4s
Response Time Analog Output	< 3ms
Integrated Watchdog	yes

ProSense® EPS Series (-1001) Digital Pressure Sensors

ProSense EPS (-1001) Series General Specifications Continued			
Environment			
Ambient Temperature	-13 to 176°F [-25 to 80°C]		
Medium Temperature	-13 to 176°F [-25 to 80°C]		
Storage Temperature	-40 to 212°F [-40 to 100°C]		
Protection	IP65 / IP67		
Mechanical			
Process Connection	1/4" NPT male		
Materials (wetted parts)²	<table style="width: 100%; border: none;"> <tr> <td style="width: 50%; text-align: center;">< 3600 psig measuring range Stainless steel 316L (DIN 1.4404)</td> <td style="width: 50%; text-align: center;">> 3600 psig measuring range Stainless steel 17-4 / 630 (DIN 1.4542) Ceramics FKM</td> </tr> </table>	< 3600 psig measuring range Stainless steel 316L (DIN 1.4404)	> 3600 psig measuring range Stainless steel 17-4 / 630 (DIN 1.4542) Ceramics FKM
< 3600 psig measuring range Stainless steel 316L (DIN 1.4404)	> 3600 psig measuring range Stainless steel 17-4 / 630 (DIN 1.4542) Ceramics FKM		
Housing Materials	Stainless steel 17-4 PH / 630 (DIN 1.4542); stainless steel 316L (DIN 1.4404); PBT+PC-GF 30; PBT-GF 20; PC		
Min. Pressure Cycles	100 million		
Tightening Torque	50Nm (depends on lubrication, seal and pressure rating)		
Restrictor Element Integrated	no		
Displays			
Engineering Units	3, 4 or 5 x LED green (depending on model), 10mm character height		
Switching Status	2 x LED yellow		
Measured Values	4-digit alphanumeric display / alternating indication of red and green		
Electrical Connection			
Connection	4-pin M12 quick-disconnect; gold-plated contacts		
Tests / Approvals			
Pressure Equipment Directive	97/23/EG: Group 2 (Non-Hazardous, Nonflammable, Non-Oxidizing fluids or gases) in accordance with sound engineering practice		
EMC	DIN EN 61000-6-2 DIN EN 61000-6-3		
Shock Resistance	DIN EN 60068-2-27 (50g 11ms)		
Vibration Resistance	DIN EN 60068-2-6 (20g 10 to 2000 Hz)		
Agency Approvals	UL file # E320431, CE, RoHS		

* BFSL = Best fit straight line / LS = Limit value setting

** With temperature fluctuations < 10°C

*** in % of the span / 6 months

¹ To EN50178, SELV, PELV

² Not cleaned for oxygen service

proense® EPS Series (-1001) Digital Pressure Sensors

EPS Wiring Diagram

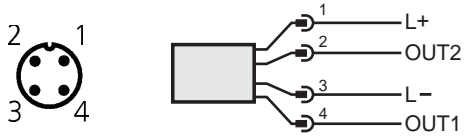

Cable Assembly Wiring Colors:
 Pin 1 - Brown
 Pin 2 - White
 Pin 3 - Blue
 Pin 4 - Black

Note: Wiring colors are based on AutomationDirect CD12L and CD12M 4-pole cable assemblies.

EPS 1001 Series Wiring Examples

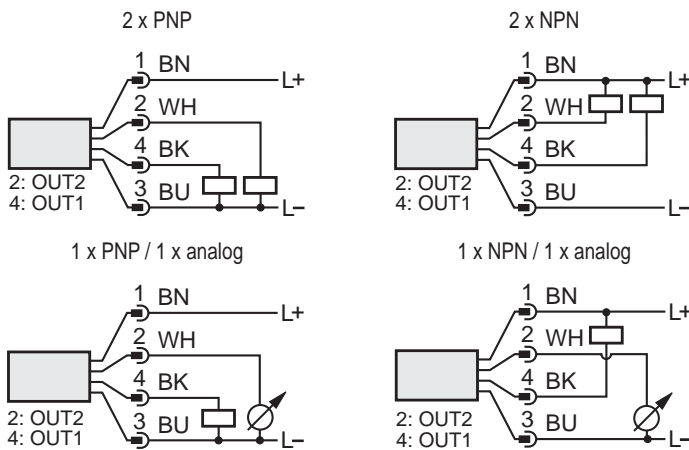

Dimensions

mm [inches]

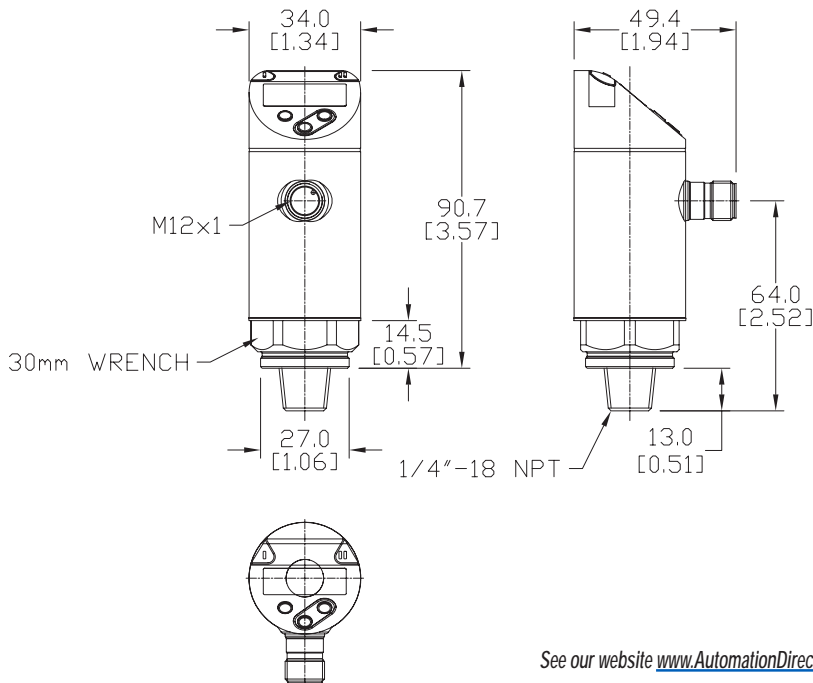

See our website www.AutomationDirect.com for complete Engineering drawings.

pro^{sense}® EPS Series Digital Pressure Sensors

Overview



AutomationDirect's ProSense EPS Series of Digital Pressure Sensors is ideal for industrial pressure measurement and indication in both gas and liquid applications. Measuring ranges are available from vacuum up to 5800 psig as well as other selectable engineering units such as bar, mbar, kPa, MPa, inches of water column, and inches of mercury. The standard 1/4" NPT male process connection allows for direct installation without requiring extra fittings. With no moving parts such as pistons or springs that can stick or break, the two solid state switch outputs provide a reliable alternative to mechanical pressure switches. Models are also available that allow the second output to be configured as a scalable analog signal turning the unit into a combination pressure switch and transmitter. The built-in two-color digital display is easy to read from a distance and provides indication of measured pressure and switch setpoints. It can be set to change

color between red and green based on measured value or output status and rotated 180° for installation flexibility. Two large bright LEDs indicate output status. For optimum visibility the sensor housing can be rotated 345° after installation. Simple pushbutton setup allows the EPS to be easily and quickly configured prior to installation without the need for a separate pressure reference gauge. Encased in a stainless steel housing the EPS allows for a high IP67 ingress protection rating achieving its atmospheric pressure reference via the 4-pin M12 electrical connection. A protective cover and mounting bracket are available accessories. The compact and robust design and construction of the ProSense EPS series withstands extreme shock and vibration, provides high accuracy and reliability, and incorporates the best combination of over pressure, burst pressure and long term stability for each measuring range.

ProSense EPS Digital Pressure Sensors Selection Guide							
Part Number	Price	Pressure Range	Selectable Engineering Units	Process Connection	Electrical Connection	Operating Voltage	Outputs
EPS25-V14-1001	\$288.00	-14.5 to 14.5 psig	psig, mbar, kPa, inH ₂ O, inHg	1/4" NPT male	4-pin M12 quick-disconnect	18 to 30 VDC	OUT 1: Switch (selectable N.O. or N.C. / PNP or NPN) OUT 2: Switch (selectable N.O. or N.C. / PNP or NPN) or Analog (selectable 4-20 mA or 0-10 VDC)
EPS25-100WC-1001	\$288.00	-5 to 100.4 inH ₂ O	inH ₂ O, mbar, kPa, mmWS				
EPS25-14-1001	\$288.00	-0.72 to 14.5 psig	psig, mbar, kPa, inH ₂ O				
EPS25-36-1001	\$288.00	-1.8 to 36.25 psig	psig, bar, kPa				
EPS25-V145-1001*	\$288.00	-14.6 to 145 psig	psig, bar, MPa				
EPS25-360-1001*	\$288.00	-14.5 to 362.5 psig	psig, bar, MPa				
EPS25-1450-1001*	\$288.00	0 to 1450 psig	psig, bar, MPa				
EPS25-3620-1001	\$288.00	0 to 3625 psig	psig, bar, MPa				
EPS25-5800-1001	\$288.00	0 to 5800 psig	psig, bar, MPa				
EPS25-V14-1003	\$253.00	-14.5 to 14.5 psig	psig, mbar, kPa, inHg				
EPS25-14-1003	\$253.00	0 to 14.5 psig	psig, mbar, kPa, inHg				
EPS25-36-1003	\$253.00	0 to 36.2 psig	psig, bar, kPa				
EPS25-V145-1003*	\$253.00	-14.5 to 145 psig	psig, bar, MPa				
EPS25-360-1003*	\$253.00	0 to 362 psig	psig, bar, MPa				
EPS25-1450-1003*	\$253.00	0 to 1450 psig	psig, bar, MPa				
EPS25-3620-1003	\$253.00	0 to 3620 psig	psig, bar, MPa				
EPS25-5800-1003	\$253.00	0 to 5800 psig	psig, bar, MPa				

* For gas applications 362 psig (25bar) maximum pressure!



EPS Series Digital Pressure Sensors - Accessories



Part No. EPS-CV

EPS Series Digital Pressure Sensors - Accessories			
Part No.	Description	Price	Wt (lb)
EPS-CV	ProSense protective cover, for use with ProSense EPS series digital pressure sensors.	\$5.50	0.1
EPS-BKT1	ProSense mounting bracket, for use with ProSense EPS series digital pressure sensors.	\$7.25	0.1

EPS Series Digital Pressure Sensor Accessory Specifications	
Part No.	Material
EPS-CV	PP (polypropylene)
EPS-BKT1	Fiber and mineral reinforced polyamide



Part No. EPS-BKT1

Dimensions

mm [inches]

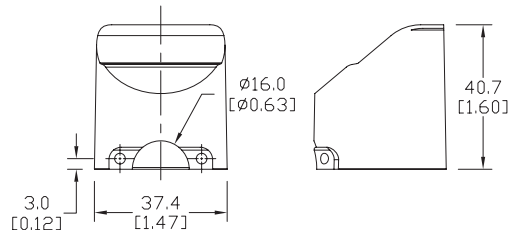

Part No. EPS-CV

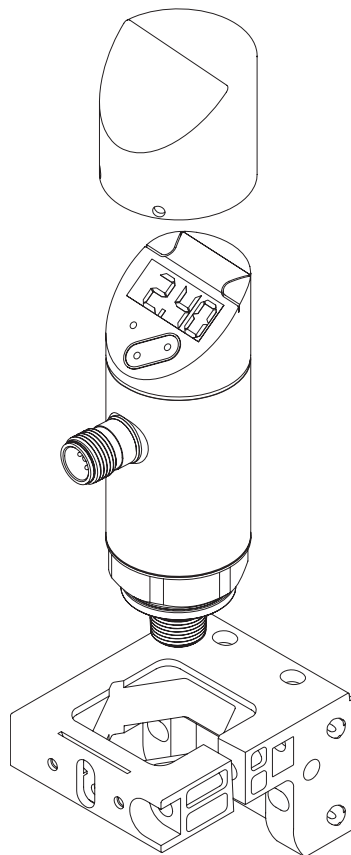

Assembly Example

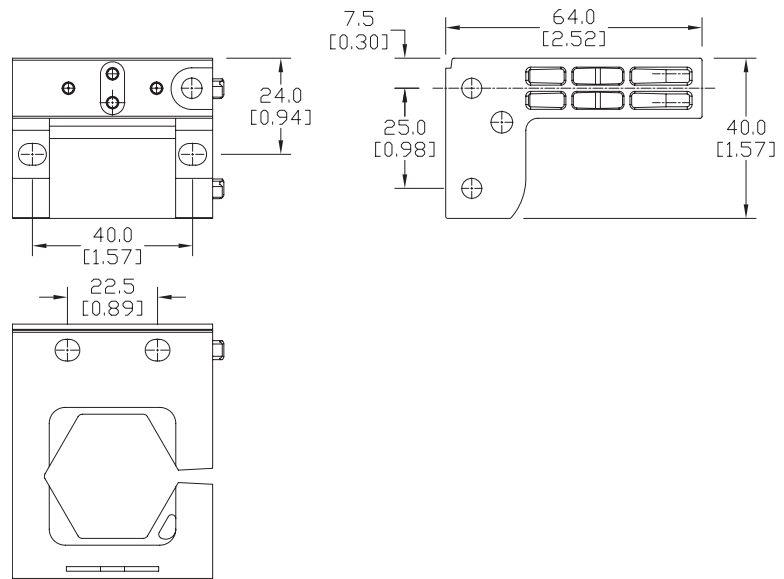

Part No. EPS-BKT1

See our website www.AutomationDirect.com for complete Engineering drawings.