

Drive features

- Power: 3 or 6 Amps, 24-80 VDC
- Supports EtherCAT, pulse input, and indexing control modes
- Switch between semi-closed loop control, fully-closed loop control, and dual feedback control
- Fully-closed loop control provides quick response with internal and external encoder position values as well as ensuring high-precision control during machine operation
- Dual feedback control - uses the motor encoder and allows the highest gains during motion, but uses the secondary encoder for precise positioning when the motor stops.
- Free Drive CM configuration software
- Multiple encoder support: the drive can accept standard incremental quadrature encoder input and can also accept BiSS Absolute (single turn or multi-turn 16-bit), BiSS general, Panasonic single-turn or multi-turn, Nikon, or SSI encoder formats
- High speed pulse input:
 - Positioning control through high speed pulses from a PLC or motion controller. Acceptable formats: quadrature (A+B), CW/CCW, Pulse+Direction
 - Provides position control through I/O without position control module
- Indexing control:
 - Select and command multiple moves with general purpose digital inputs (not high-speed)
 - Configure the move distances, speeds, accel/decels with DriveCM software and select them at runtime with digital inputs (from a PLC, selector switches, etc.)
- Analog input and preset speed/torque:
 - Use the analog input to control motor speed or torque when in Speed Mode or Torque Mode, or configure preset speed/torque values with DriveCM and select them with digital inputs
 - The analog input can also be used as a speed override signal to modify the motor speed when the drive is Indexing Control
 - The analog input can be used as a torque limit when the drive is in Indexing Mode (or in EtherCAT Profile Position Mode)
- Real-time control through EtherCAT:
 - High speed, real-time control and synchronization mechanism
 - Supports CoE, EoE, and FoE
 - Synchronous and Profile modes
 - Improved frequency response (1kHz)
 - Improved communication speed by applying 16-bit bus
- The 1 kHz bandwidth (frequency response) allows for high-level automatic tuning. Several modes of tuning are available including Off-Line Auto Tuning (the drive initiates its own move commands while Auto tuning), On-Line Auto Tuning (an external controller sends the move commands while the drive Auto tunes), and Manual Tuning (all tuning values are adjusted by the user).
- Variable switching frequency of motor power signals - 16/32/48 kHz. User can adjust the frequency to minimize electrical noise or interference.
- (4) Optically isolated configurable digital inputs and (4) user configurable outputs
- Advanced Scope feature that can monitor a variety of command and status signals, including output speed, torque, power, etc.



- STO: Safe Torque Off input eliminates the need for large contactors to drop power from the drive when an E-stop occurs
- Separate brake output connector: no interposing relay needed when using the dedicated 1A output for motor holding brake.
- Analog Outputs: use the two analog outputs to monitor

Motor features

- Low inertia 3000rpm motors available:
 - 100W, 40mm frame size
 - 100W, 200W, and 300W, 60mm frame size
- Permanent magnet 3-phase synchronous motor
- Keyed drive shafts support clamp-on style couplings or key-style couplings (100W FAL01 motors have smooth shafts, no key)
- Integrated multi-turn absolute encoder with 19-bit resolution (524,288 pulses per revolution) except FAL01 motors with 18-bit (262,144 ppr)
- Optional 24 VDC spring-set holding brakes (AM8N2 and AMK2 motors)
- Professionally manufactured cables available for motor power, encoder feedback, and (optional) brake, in standard or continuous flexing versions (3m, 5m, 10m, or 20m lengths)
- Standard 26-pin DIN-rail mounted break-out kit for the drive's CN1 connector (with screw terminal connections), or 26-pin cables with flying leads

Note: These parts available for sale to North American locations only.



Tuning Technology

The PHOX drive closes the loop on current, velocity, and position (depending on control mode selection). The 1kHz bandwidth in the drive assures precise speed and current control and easy tuning. Proportional gain, integral gain and compensation, feed forward compensation, command low pass filter, and four (4) notch filters (and Adaptive notch filters) for resonance suppression are available. Auto Tuning has been greatly improved and can tune motors up to 30:1 inertia mismatch.

There is an inertia estimation function that analyzes the motor and load during Auto Tuning to measure how much inertia is coupled to the motor.

The drive has several tuning methods available:

- Online Auto Tuning—the drive can either tune the load live while an external controller moves the load to different positions or using the drive's internal tuning motion profile.
- Offline Auto Tuning—the drive tunes the load using the drive's internal tuning motion profile.
- Manual Tuning—all parameters are available to give power users the ultimate flexibility to tune their systems.

Control Modes

When connected to an EtherCAT® Master, the PHOX drive can run in Cyclic Synchronous Modes (Position, Velocity, Torque) where the Master controller sends an updated setpoint every EtherCAT® cycle (~1millisecond). In these modes, the upper controller plans the motion path.

The drive can also work in EtherCAT Profile Modes (Position, Velocity, Torque) where the Master Controller sends one setpoint for each move. In these cases, the drive's accel, decel, and max speed settings determine the motion path planning. The drive also has 21 different homing modes to accommodate most applications.

In non-EtherCAT applications the PHOX can work as a standard servo, accepting high-speed pulse inputs, Indexing commands (general purpose Digital inputs to initiate and select different Index moves), analog or preset modes, or analog or preset torque modes.

Optional Holding Brake

Each servo motor can be ordered with an integrated 24VDC spring-set holding brake that holds the motor in place when power is removed.

LS Electric MSS Series In-Line Planetary Precision Gearboxes for Servo Motors

Need more torque from the motor? Have an inertia balancing issue in your design? The LS Electric MSS series gearboxes easily mate to 60mm FBL motors. SureGear gearboxes are available for the 40mm 100W FAL motors. Everything you need for mounting is included!



- Three MSS gear ratios available (5:1, 10:1, 20:1)
- Five SureGear gear ratios available for 40mm 100W FAL motors (5:1, 10:1, 15:1, 25:1, 50:1)
- Mounting hardware included for attaching to motors.
- Industry-standard mounting dimensions
- Thread-in mounting style
- Very low backlash: 7 arc-min or 9 arc-min (20:1 ratios).
- 1-year warranty

Servo drive overview

Motor Output Terminal

Output power to the servo motor. LS motor power cables available in 3, 5, 10, and 20 meter lengths in standard and flexing cables.

Brake Output Connector

Separate connector to wire a motor brake. Can handle 1A current output (no need for an interposing relay). Optional brake cables are available (APCS-BxxxQS-AD). The mating brake connector (PHOX-CON-C) and crimp pins (PHOX-CON-D) are included with each drive.

EtherCAT® Com Ports

(ECAT IN, ECAT OUT). Used for connection to the EtherCAT controller. 4 Status LEDs indicate the operational status of the EtherCAT network and its error state.

Addressing Switches

DIP switches 1–7 set the EtherCAT Node Address. DIP switch 8 is for factory use only - do not turn ON.

USB Connector

Configuration: connect to PC (with Drive CM software) via a standard USB A to USB mini-B cable (SV2-PGM-USB15, MOSAIC-CSU, or similar).

Firmware Upgrade: Use Drive CM software or attach a USB thumb drive with the new FW and update using USB On the Go (no PC required). See the User Manual for details.

Safe Torque Off Connector (STO)

Optional STO cable is available (APCS-PHOX-STOxxA-AD). The mating STO connector (PHOX-CON-B) and crimp pins (PHOX-CON-D) are included with each drive.

Input/Output Connector (I/O)

26-pin CN1 connector for drive I/O. Signals include high speed pulse inputs, 4 configurable digital inputs, 4 configurable digital outputs, 1 analog input (torque limit), and scalable encoder output.

Control Power Terminal

Optional 24-80VDC control power (this is the AUX+ AUX- terminals on the power terminal strip)

Power Terminal

Incoming 24-80 VDC (these are the HV+ HV- terminals on the power strip)

Status LED

Indicates current state of the drive: Green blinking indicates the operational status of the drive. Red blinking indicates error status. See the user manual for descriptions of the blinking codes.

Encoder Connector

HD15 connectors ENC A and ENC B for motor and secondary encoder. LS Encoder cables available in 3, 5, 10, and 20 meter lengths in standard and flexing cables.

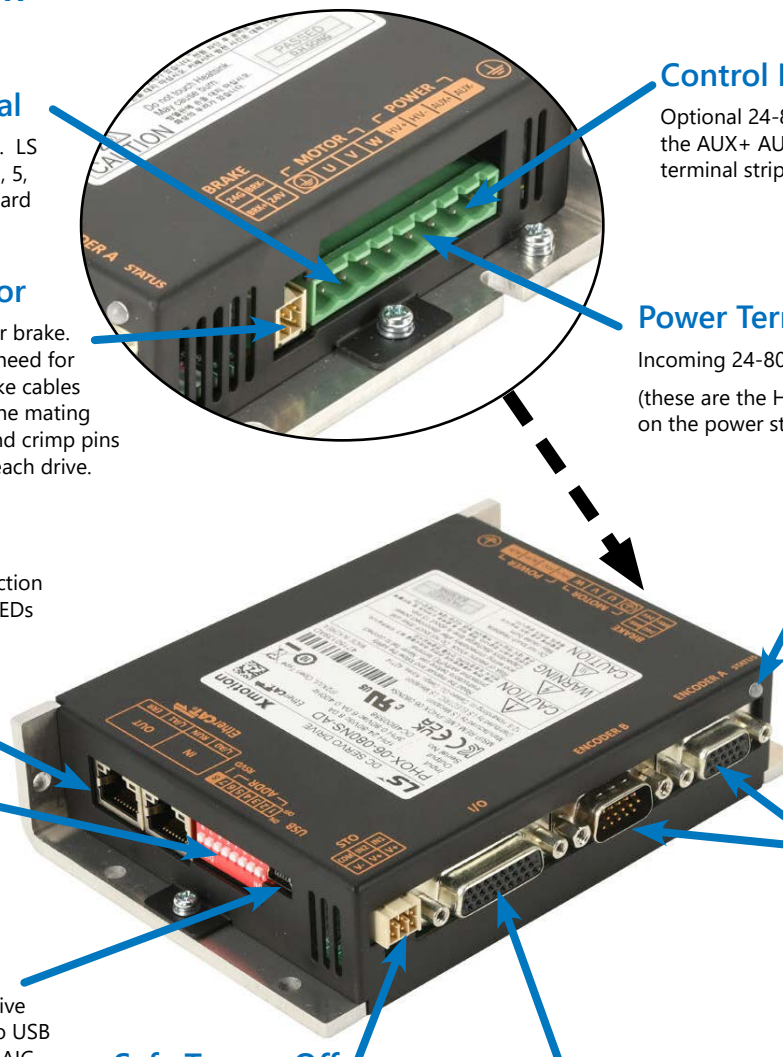

The LS Electric PHOX servo drives are fully digital and include over 300 parameters to configure the drive for almost any application. For convenience, the parameters are grouped into several categories including:

- Basic parameters
- Gain parameters
- I/O parameters
- Velocity parameters
- Misc. parameters
- Monitor parameters

All parameters have commonly used default values which allow you to operate the PHOX drive "out-of-the-box". The drive auto-detects the LS servo motor (through the serial encoder) and sets up the default gains and limits based on the connected motor.

Additionally, the drive can be custom configured to your specific application. The Drive CM configuration software has a built-in Setup Wizard that will guide you through all the basic setup parameters. The Setup Wizard will quickly and easily get your application started – from setting up the I/O to determining the appropriate homing sequence.

It's also possible to configure these drives across an EtherCAT network via a compatible EtherCAT controller (such as XBF-PN04B or XBF-PN08B EtherCAT cards and the XGB PLC). This has the added advantage of consolidating/storing multiple drive configurations in a single repository.

After configuration is complete, the Auto Tune features of the drive will get your application tuned for optimal responsiveness and performance.

Servo motor overview

FAL/FBL Series Motor

Encoder Connector

9-pin watertight connector for the serial encoder. The encoder transmits motor/encoder identification information to the drive at power-up and sends position feedback during operation.

FAL 100W = 18-bit serial encoder (262,144 pulses per revolution)

All other motors = 19-bit serial encoder resolution (524,288 pulses per revolution).

All encoders have 16-bit multi-turn resolution (the shaft can turn $2^{16} = 65536$ full revolutions before the count rolls over)

Brake Power Connector

2-pin watertight connector available on FAL/FBL brake motors only. The 24VDC brake is located between the motor coils and the encoder. Motors ending in NM82 and AMK2 have brakes. The brakes must have 24VDC applied to them before the motor is set in motion.

Low Inertia Motors

Low inertia designs result in high responsiveness at high speeds for lighter loads.

- 100–300W motors available
- FAL motors have 40mm flanges
- FBL motors have 60mm flanges

Motor Shafts

FBL motors are supplied with extra-large keyways, and slightly oversized keys which may need to be "fitted" into the keyway for performance and longevity. Clamp or compression couplings (without key) are recommended. FAL motors do not have a key/keyway.

- 100W FAL 8mm diameter shaft
- 100W FBL 14mm diameter shaft
- 200W FBL 14mm diameter shaft
- 300W FBL 14mm diameter shaft

Motor Power Connector

4-pin watertight connector for motor power (U, V, W, and ground)

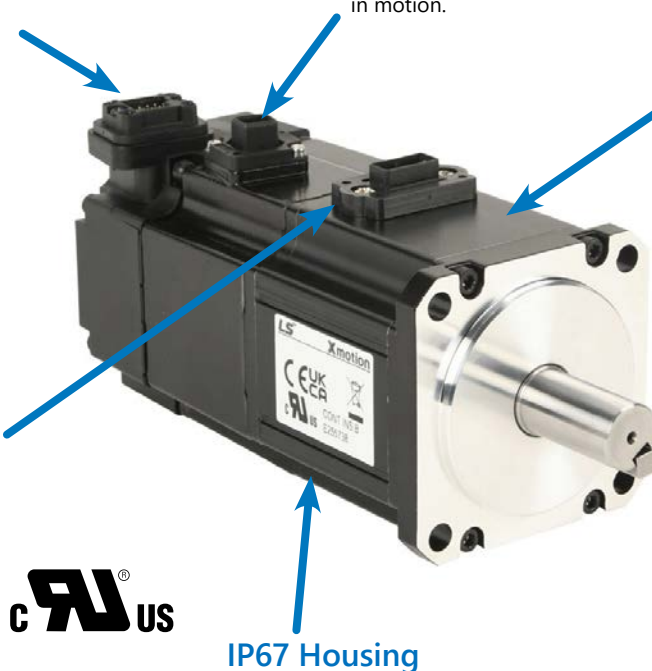

IP67 Housing

All LS Electric FBL motors have keyed shafts for use with servo-grade clamp or compression couplings (recommended) or servo-grade keyed couplings. Some sanding/filing of the key may be required before pressing into the keyway. Do not modify the shaft/keyway.

How to select and apply PHOX systems

The primary purpose of the AC servo system is to precisely control the motion of the load. The most fundamental considerations in selecting the servo system are "reflected" load inertia, servo system maximum speed requirement, servo system continuous torque requirement, and servo system peak torque requirement. In a retrofit application, select the largest torque servo system that most closely matches these parameters for the system being replaced. In a new application, these parameters should be determined through calculation and/or

measurement. The Drive CM software has the ability to measure the load (reflected) inertia and accurately measure the motor torque output.

AutomationDirect has teamed with Copperhill Technologies to provide free servo-sizing software. "VisualSizer-SureServo" software will assist in determining the correct motor and drive for your application by calculating the reflected load inertia and required speed and torque based on the load configuration. "VisualSizer-SureServo" software can be downloaded from <https://support.automationdirect.com/products/lselectric.html>.

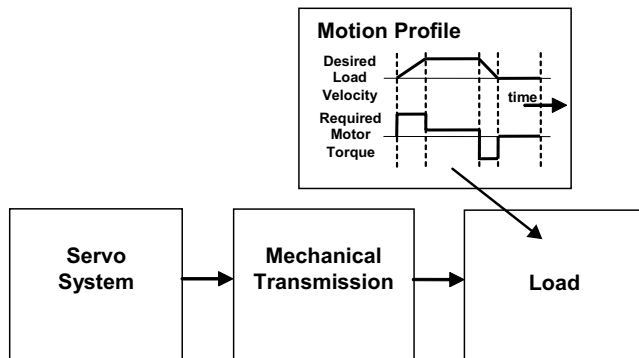

1. "Reflected" load inertia

The inertia of everything attached to the servo motor driveshaft needs to be considered and the total "reflected" inertia needs to be determined. This means that all elements of any mechanical transmission and load inertia need to be translated into an equivalent inertia as if attached directly to the motor driveshaft. The ratio of "reflected" load inertia to motor inertia needs to be carefully considered when selecting the servo system.

In general, applications that need high response or bandwidth

will benefit from keeping the ratio of load inertia to motor inertia as low as possible and ideally under 10:1. PHOX Auto Tuning will still tune a system with very high response, up to 30:1 inertia mismatch. Higher system ratios can be implemented, but corresponding lower bandwidth or responsiveness must be accepted. The servo response including the attached load inertia is determined by the servo tuning. The PHOX servo systems may be tuned automatically by the software/drive or manually by the user.

2. Torque and speed

With knowledge of the motion profile and any mechanical transmission between the motor and load, calculations can be made to determine the required servo motor continuous torque, peak torque, and maximum motor speed. The required amount of continuous torque must fall inside the continuous operating region of the system torque-speed curve (you can check the continuous torque at the average speed of the motion profile). The required amount of peak torque must also fall within the servo system's intermittent operating region of the system torque-speed curve (you need to check this value at the required maximum speed or torque). If you have a PHOX system, these values are easily captured and recorded with the Scope feature built into the Drive CM software. If you are designing the system from scratch, use VisualSizer to define the system and calculate expected inertia and required power.

Compare the application's continuous and intermittent torque requirements to the torque-speed curves found in Chapter 12.8 of the PHOX User Manual or in the system torque charts found on "PHOX AC servo drive, motor, and cable combinations" on page tMNC-228.

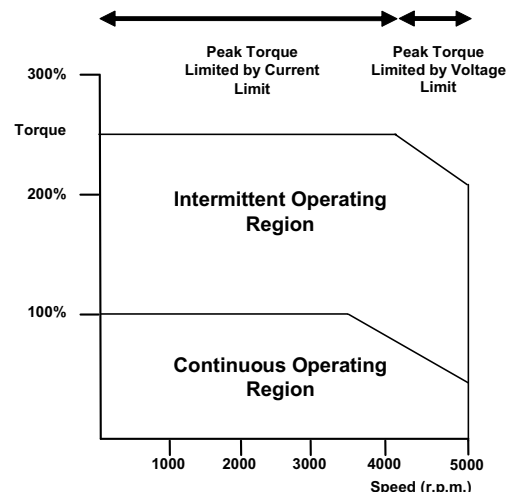

Application tip - coupling considerations

The LS Electric FBL motors have keyed shafts that can be used with keyed couplings or with clamp-on or compression style couplings. FAL motors are smooth shaft only. For standard keyed couplings, the servo key must be "fitted" into the keyway for optimum performance and longevity. Some minor filing and pressing of the key may be required. "Servo-grade" clamp-on or compression style couplings are usually the best choice when

you consider stiffness, torque rating, and inertia. Higher stiffness (lb-in/radian) is needed for better response but there is a trade-off between stiffness and the added inertia of the coupling. Concerning the torque rating of the coupling, use a safety factor of 1.25 over the servo's **peak** torque requirement of your application.

[Click here for Available Couplings](#)

Mechanical transmissions

Common mechanical transmissions include leadscrews, rack & pinion mechanisms, conveyors, gears, and timing belts. The use of leadscrew, rack & pinion, or conveyor are common ways to translate the rotary motion of the servo motor into linear motion of the load. Matched gearboxes are available from LS Electric that will work with the LS servo motors. Each gearbox is selected to accept the 300% maximum available torque that could be generated by the motor. Gearboxes are available in 5:1, 10:1, and 20:1 ratios. The use of a speed reducer such as a gearbox or timing belt can be very beneficial as follows:

1. Reduction of reflected load inertia

As a general rule, keep the reflected load inertia as low as possible while using the full range of servo speed. The LS Electric motors can rotate at a rated speed of 3000 rpm (rated torque at rated speed). Their max speed (slightly less available torque) is 3300 rpm. See the speed-torque curves for more information.

Example: A gearbox reduces the motor's required torque by a factor of the gear ratio, and reduces the reflected load inertia by a factor of the gear ratio squared. A 10:1 gearbox reduces output speed to 1/10, increases output torque 10 times, and decreases reflected inertia to 1/100.

However, when investigating the effect of different speed reduction ratios DO NOT forget to include the added inertia of couplings, gearbox, or timing belt pulleys. These added inertias can be significant, and can negate any inertia reduction due to the speed reduction.

2. Low speed and high torque applications

If the application requires low speed and high torque then it is common to introduce a speed reducer so that the servo system can operate over more of the available speed range. This could also have the added benefit of reducing the servo motor torque requirement which could allow you to use a smaller and lower cost servo system. Additional benefits are also possible with reduction in reflected inertia, increased number of motor encoder counts at the load, and increased ability to reject load disturbances due to mechanical advantage of the speed reducer.

3. Space limitations and motor orientation

LS Electric servo motors can be mounted in any orientation, but the shaft seal should not be immersed in oil (open-frame gearbox, etc.). Reducers can possibly allow the use of a smaller motor or allow the motor to be repositioned.



[Here is a link to our Timing Belts and Pulleys](#)

Motor	Brake Motor	Planetary In-Line Gearboxes					
		5:1 Gearbox	10:1 Gearbox	15:1 Gearbox	20:1 Gearbox	25:1 Gearbox	50:1 Gearbox
APMC-FAL01AM8N-8-AD	APMC-FAL01AM8N2-8-AD	PGA050-05A1	PGA050-10A1	PGA050-15A1	<i>n/a</i>	PGA050-25A1	PGD064-50A1
APMC-FBL01AMK-8-AD	APMC-FBL01AMK2-8-AD	96200004	96200005	<i>n/a</i>	96200103	<i>n/a</i>	<i>n/a</i>
APMC-FBL02AMK-8-AD	APMC-FBL02AMK2-8-AD						
APMC-FBL03AMK-8-AD	APMC-FBL03AMK2-8-AD						

Ordering Guide

The following pages are your ordering guide for LS Electric PHOX servo systems. Each system has a torque-speed curve included for reference. This is the fundamental information that you need to select the servo motor and matching drive for your application.

Each system needs:

- Drive and Motor
- Motor Power Cable
- Motor Encoder Cable
- I/O connections (either a 26-pin CN1 cable+terminals kit or a 26-pin flying lead cable (user provides terminal blocks))
- Brake motors require a brake cable.
- STO cable (APCS-PHOX-STOxxA-AD) (optional). An STO connector (PHOX-CON-B) is included with each drive.

PHOX series drives and motors part numbering system

Drives

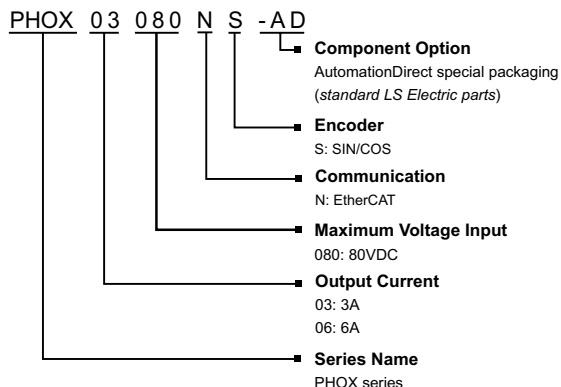

Motors

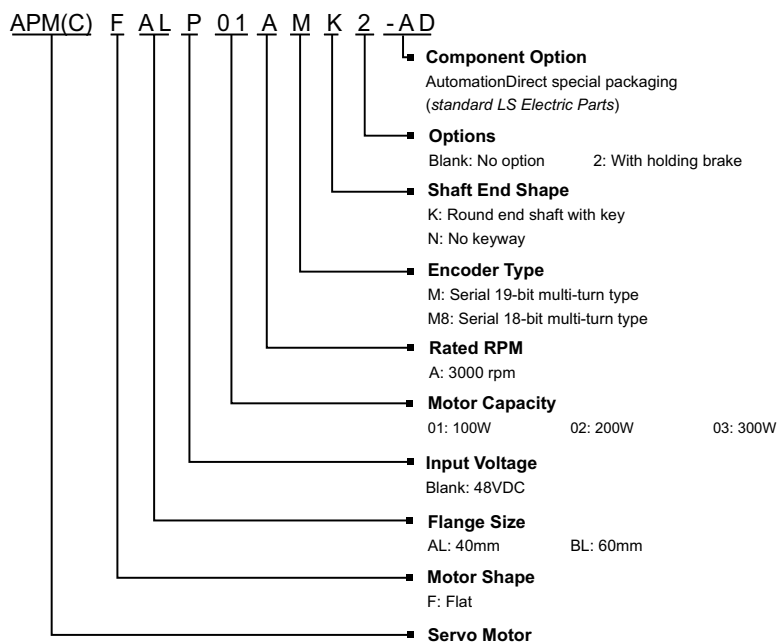

Example of what you will need to build a complete servo system:

Servo Drive **Servo Motor** **Motor Power Cable** **Motor Encoder Cable** **I/O and STO Interface**

Completed motor assembly (with optional gearbox)

NOTE: AMPC-FAL/FBL brake equipped motors will also require a separate brake power cable.

NOTE: Required programming software (free download). Use a standard USB-A to USB mini-B cable for connectivity (SV2-PGM-USB15, MOSAIC-CSU, or equivalent)

NOTE: If you need a gear box for your configuration, reference the gearbox chart on the previous page.





PHOX Series Servo Systems

Torque to PHOX System Quick Reference

System Rated Torque (N·m)	System Maximum Torque (N·m)	Suggested Servo Motor	Required Servo Drive
0.32	0.96	APMC-FAL01AM8N-8-AD	PHOX-03-080NS-AD
		APMC-FAL01AM8N2-8-AD	
		APMC-FBL01AMK-8-AD	
		APMC-FBL01AMK2-8-AD	
0.64	1.92	APMC-FBL02AMK-8-AD	PHOX-06-080NS-AD
		APMC-FBL02AMK2-8-AD	
0.95	2.54	APMC-FBL03AMK-8-AD	
		APMC-FBL03AMK2-8-AD	



PHOX Series Servo Systems

PHOX DC servo drive, motor, and cable combinations

xx = Cable length in meters

BN/EN/PN = Standard cable (not continuous flex)

BF/EF/PF = Flex-rated cable

AM8N/AMK motors = no brake

AM8N2/AMK2 motors = mechanical holding brake

48VDC AM8N/AMK Motor Systems

Type	System Torque Chart	PHOX Drive	APM/APMC Motor	Power Cable	Encoder Cable	Brake Cable	I/O Wiring Options
100W Low Inertia System (FAL motor)		PHOX-03-080NS-AD	APMC-FAL01AM8N-8-AD	APCV-PNxxLS-AD	APCV-ENxxES1-AD	n/a	APCS-PHOX-IOTxx-AD (cable and breakout) or APCS-PHOX-IOxxA-AD (connector-to-pigtail cable)
				APCV-PFxxLS-AD	APCV-EFxxES1-AD		
			APMC-FAL01AM8N2-8-AD	APCV-PNxxLS-AD	APCV-ENxxES1-AD	APCV-BNxxQS-AD	
				APCV-PFxxLS-AD	APCV-EFxxES1-AD	APCV-BFxxQS-AD	
100W Low Inertia System (FBL motor)		PHOX-03-080NS-AD	APMC-FBL01AMK-8-AD	APCV-PNxxLS-AD	APCV-ENxxES1-AD	n/a	
				APCV-PFxxLS-AD	APCV-EFxxES1-AD		
			APMC-FBL01AMK2-8-AD	APCV-PNxxLS-AD	APCV-ENxxES1-AD	APCV-BNxxQS-AD	
				APCV-PFxxLS-AD	APCV-EFxxES1-AD	APCV-BFxxQS-AD	
200W Low Inertia System		PHOX-06-080NS-AD	APMC-FBL02AMK-8-AD	APCV-PNxxLS-AD	APCV-ENxxES1-AD	n/a	
				APCV-PFxxLS-AD	APCV-EFxxES1-AD		
			APMC-FBL02AMK2-8-AD	APCV-PNxxLS-AD	APCV-ENxxES1-AD	APCV-BNxxQS-AD	
				APCV-PFxxLS-AD	APCV-EFxxES1-AD	APCV-BFxxQS-AD	
300W Low Inertia System		PHOX-06-080NS-AD	APMC-FBL03AMK-8-AD	APCV-PNxxLS-AD	APCV-ENxxES1-AD	n/a	
				APCV-PFxxLS-AD	APCV-EFxxES1-AD		
			APMC-FBL03AMK2-8-AD	APCV-PNxxLS-AD	APCV-ENxxES1-AD	APCV-BNxxQS-AD	
				APCV-PFxxLS-AD	APCV-EFxxES1-AD	APCV-BFxxQS-AD	

Note: Fxx cables are rated for continuous flexing applications, Nxx cables are not.



PHOX Series Servo Systems

PHOX Servo drive specifications

PHOX Servo Drive Specifications			
Model		<i>PHOX-03-080NS-AD</i>	<i>PHOX-06-080NS-AD</i>
Price		\$434.00	\$454.00
Drawing		PDF	PDF
Power	Input Power	24-80 VDC ¹	
	Rated Current [Amps]	3	6
	Peak Current [Amps]	9A > 1 sec	18A > 1 sec
Supported Encoder Types	Encoder A	Quadrature (Max. 10Mpps after X4) - with and without hall sensors, Differential Serial Encoder (absolute, incremental) - BiSS(B,C), Endat 2.2, Tamagawa Serial, SSI	
	Encoder B ²	Quadrature (Max. 10Mpps after X4) - without hall sensors, Differential Serial Encoder (absolute, incremental) - BiSS(B,C), Endat 2.2, Tamagawa Serial, SSI Analog Encoder - Sinusoidal (1Vpp), Analog hall (Sin/Cos) - Resolver (Optional)	
	Output Type	AO (+/-), BO (+/-), ZO (+/-), Line Driver output max 6.4 Mpps	
Control Performance	Speed Control Range	Maximum 1:5000	
	Frequency Response	Maximum 1kHz or above (when using 19-bit serial encoder)	
	Speed Variation Ratio	±0.01 % or lower (when load changes between 0 and 100%) ±0.1 % or lower (temperature 25±10°C)	
	Accel/Decel Time	Within ±1%	
	Input Frequency	4Mpps, line drive	
	Input Pulse Method	Symbol+Pulse series, CW+CCW, Phase A/B	
Recommended Fuse		PHOX-03: 5A, PHOX-06: 10A	
EtherCAT® Specification	Communication Standard	FoE (firmware download) EoE (parameter setting by UDP, tuning, secondary function, parameter copy) CoE (IEC 61158 Type 12, IEC 61800-7 CIA 402 Drive profile)	
	Physical Layer	100BASE-TX (IEEE802.3)	
	Connector	RJ45 x 2	
	Communication Distance	Maximum distance between nodes (100m)	
	DC (Distributed Clock)	Synchronization by DC mode, minimum DC cycle: 250 (µs)	
	LED Display	LinkAct IN, LinkAct OUT, RUN, ERR	
	CiA 402 Drive Profile	Profile Position Mode, Profile Velocity Mode, Profile Torque Mode, Cycle Synchronous Position Mode, Cyclic Synchronous Velocity Mode, Cyclic Synchronous Torque Mode, Homing Mode	
Digital I/O Specifications	Digital Input	4 discrete inputs (selectable). Each input can trigger one of the following 33 functions (*=default): (*POT, *NOT, *HOME, *STOP, PCON, GAIN2, P_CL, N_CL, PROBE1P, ROBE2, EMG, A_RST, SV_ON, START, PAUSE, REGT, HSTART, ISELO-5, ABS_RQ, JSTART, JDIR, PCLR, AOV, INHIB, SPD1, SPD2, SPD3, MODE)	
	Digital Output	4 discrete outputs (selectable). Each output can be configured to indicate one of the following 33 functions: (*=default) (*BRAKE, *ALARM, *READY, *ZSPD, INPOS1, INPOS2, TLMT, VLMT, INSPD, WARN, TGON, ORG, EOS, IOUT0, IOUT1, IOUT2, IOUT3, IOUT4, IOUT5)	
Analog I/O	Analog Input	One input voltage channel (allocatable), range: ±5V differential Input can be configured to indicate one of the following 4 functions (not all functions available in all Control Modes): (Speed Override, Speed Command, Torque Command, Torque Limit)	
	Analog Output	2 analog output channels (selectable), ±10V Each output can be configured to indicate one of following 24 functions: (Speed Feedback, Speed Command, Speed Error, Torque Feedback, Torque Command, Position Error, Accumulated Operation Overload, DC Link Voltage, Encoder Single-Turn Data, Inertia Ratio, Following Error Actual Value, Drive Temperature 1, Drive Temperature 2, Encoder Temperature, Hall Sensor Signal, U-phase Current, V-phase Current, W-Phase Current, Position Actual value, Position Demand Value, Position Command Speed, Hall U Value, Hall V Value, Hall W Value)	
Continued on next page			

1 - It is possible to drive with a voltage of less than 48VDC input power, but the actual maximum speed (while loaded) may be slower than the rated speed and the motor specifications cannot be guaranteed. We recommend using a minimum of 48VDC as the input power if possible. Using an input higher than 48VDC does not result in higher performance.

2 - Available when full-closed loop or dual feedback control functions are applied.



PHOX Series Servo Systems

PHOX Servo drive specifications, *continued*

PHOX Servo Drive Specifications, <i>continued</i>		
<i>Continued from previous page</i>		
<i>Model</i>	<i>All PHOX Series Drives</i>	
<i>Safety Function</i>	2 input channels (STO1, STO2)	
<i>USB Communication</i>	<i>Function</i>	Firmware download, parameter setting, tuning, auxiliary function, parameter copy
	<i>Communication Standard</i>	Complies with USB 2.0 Full-speed specifications
	<i>Connect</i>	PC or USB storage media
<i>Internal Function</i>	<i>Self-setting Function</i>	Drive node address can be set using dip switch
	<i>Additional Function</i>	Gain tuning, alarm history, JOG operation, origin search
	<i>Protection Function</i>	Overcurrent, overload, excessive current limit, overheat, overvoltage, undervoltage, overspeed, encoder error, position following error, current sensing error
<i>Operation Environment</i>	<i>Operating Temperature</i>	0 to 50 °C (32 to 122 °F)
	<i>Storage Temperature</i>	-20 to 65 °C (-4 to 149 °F)
	<i>Operating Humidity</i>	Below 80% relative humidity
	<i>Storage Humidity</i>	Below 90% relative humidity (non-condensing)
	<i>Vibration</i>	19.6 m/s ² or less
	<i>Environment</i>	Keep indoors, avoid corrosive/flammable gas or liquid, and electrically conductive dust
<i>Approvals</i>	CE, REACH, cUR _{us}	

PHOX Drive Standard Installation

PHOX Drive Installation Spacing

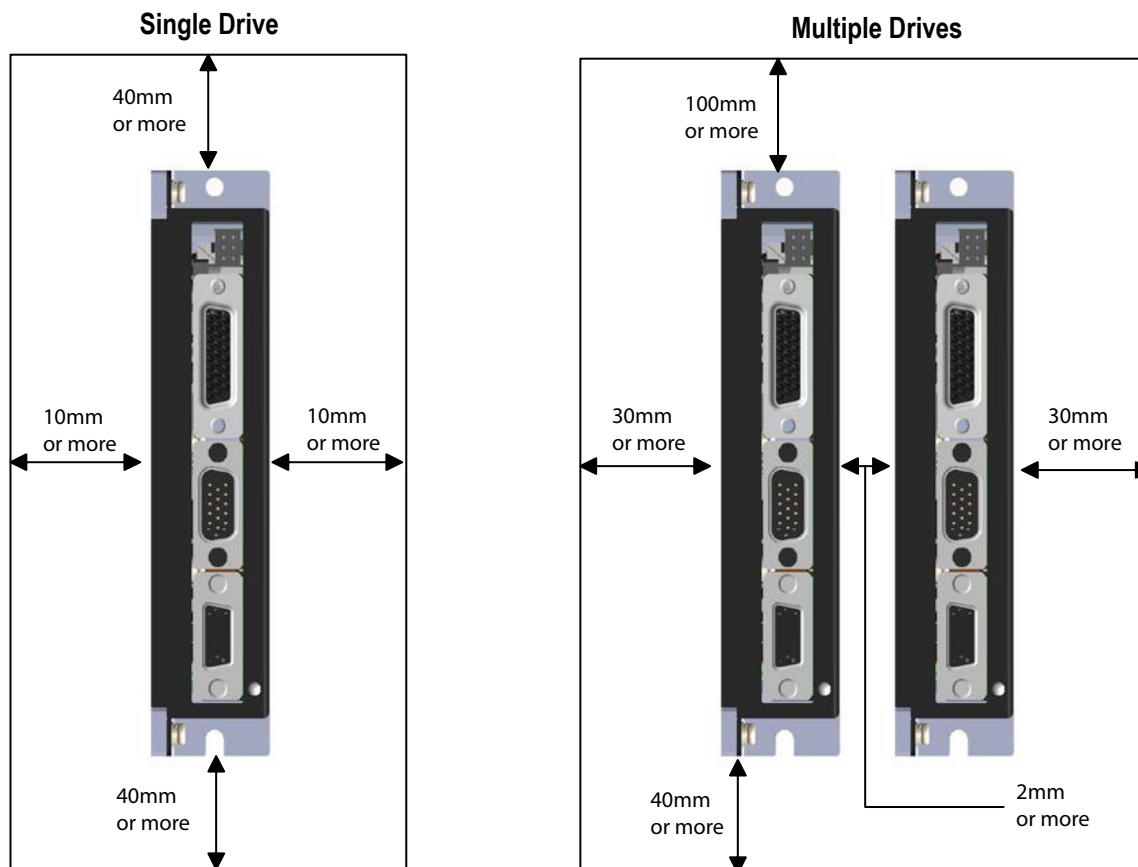

PHOX Drive Installation Concerns:

- Install external regenerative resistors so that any heat generated does not affect the drive.
- Vertical installation only. For proper heat dissipation, ensure the back of the drive makes good contact with the subpanel.
- Protect the drive from metal chips and other falling debris during control panel assembly.
- Make sure that oil, water, or metal dust do not enter the drive.
- Protect the control panel by using an air purge system when installing it in any area where there are harmful gases or dust.

PHOX Drive Wiring

PHOX Power Supply Wiring

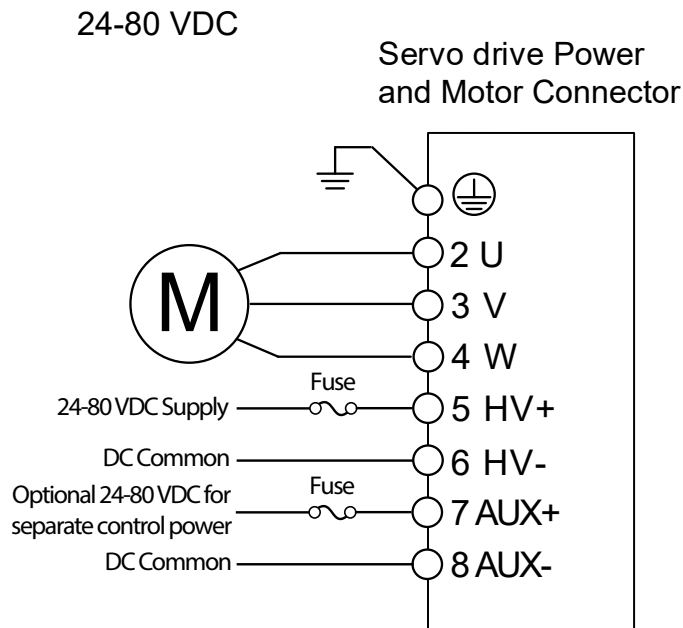

PHOX Brake Wiring (dedicated brake connector)

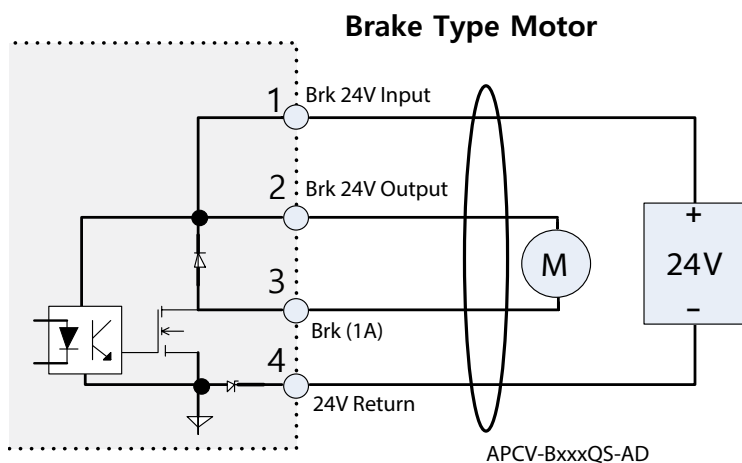

Notes:

- See available brake cables later in this section (cables contain wiring for 24VDC supply to the drive and brake power output to the motor brake).
- Or use the crimp pins and connector that ship with each drive.

PHOX Drive Wiring, *continued*

PHOX STO Wiring (*dedicated connector*)

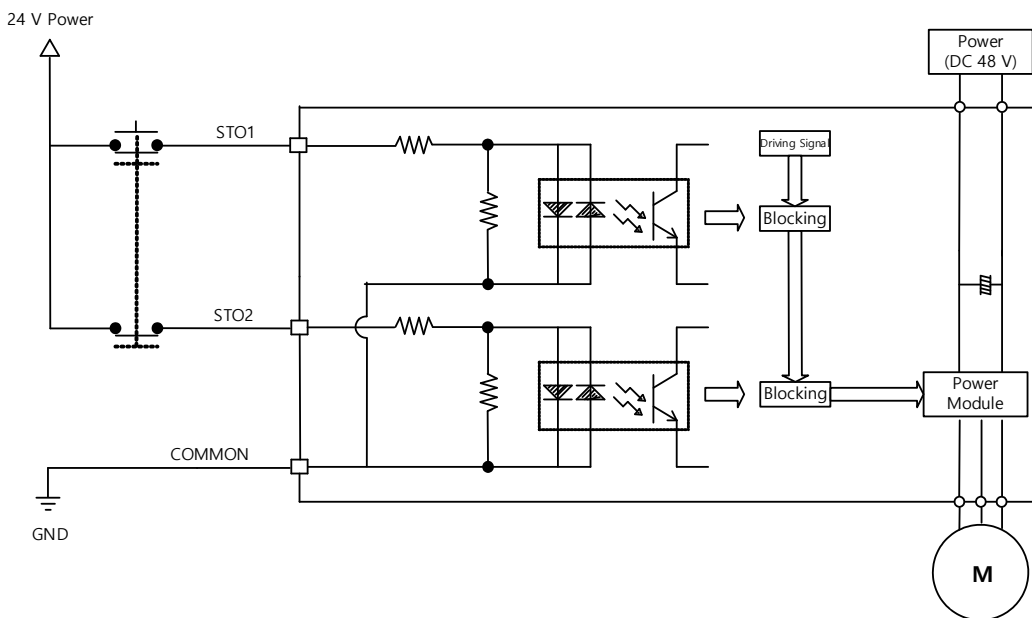

Notes:

- See available STO cables later in this section or use the crimp pins and connector that ship with each drive.

STO Bypass

To bypass STO (during commissioning/testing) connect the STO terminals as shown. Never connect anything else to V+ or V-.

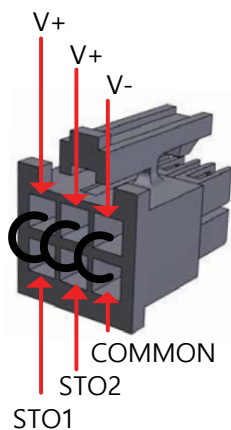

PHOX Drive Wiring, *continued*

PHOX Input/Output Signal Wiring (26-pin D-sub connector)

Note: Use the dedicated brake connector output to control the brake instead of DO1. This saves the use of a configurable digital output and eliminates the need for an interposing relay (relay is only required if using DO1 to operate a motor holding brake)

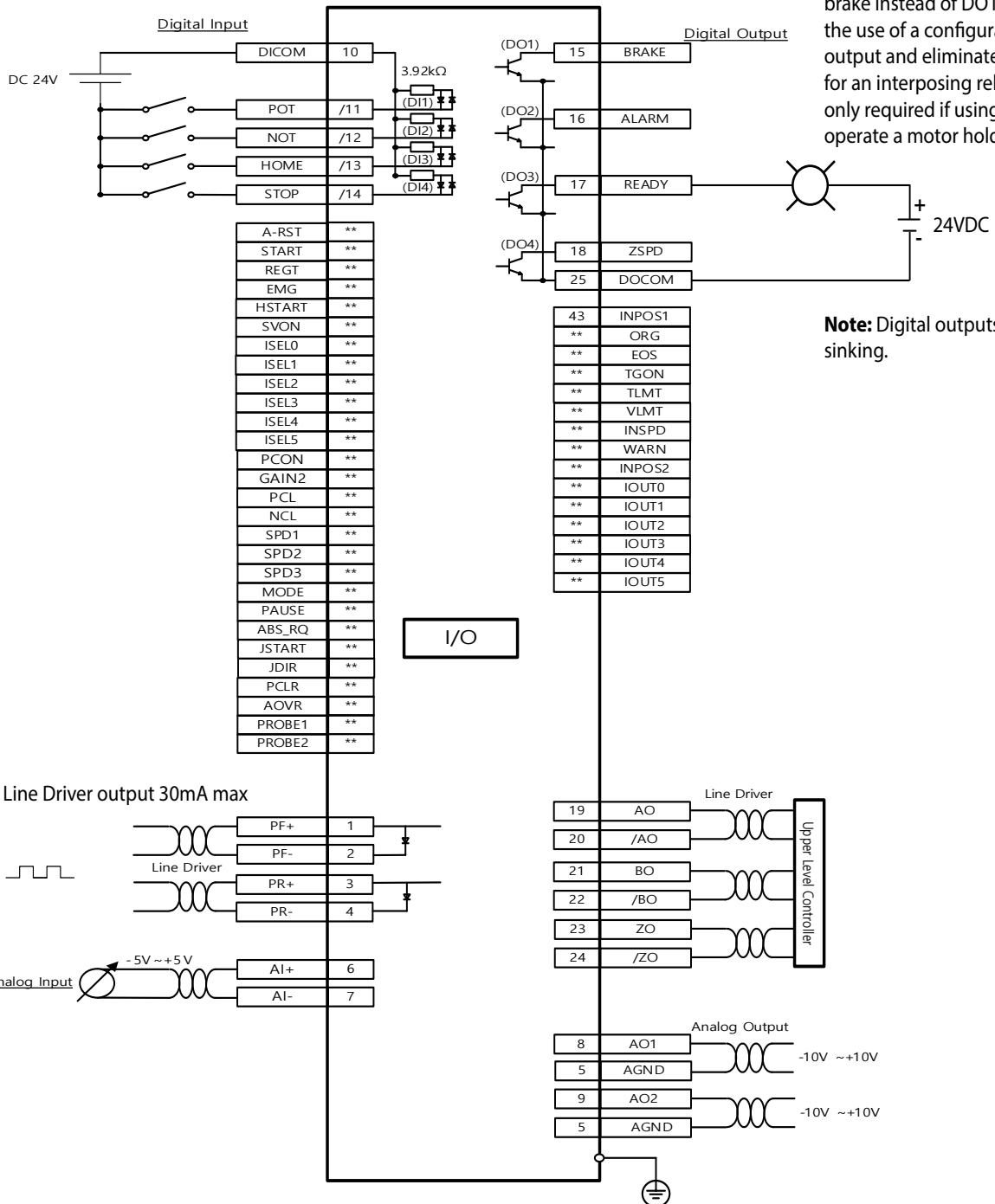

Note: Line Driver output 30mA max



PHOX Series Servo Systems

Motor Specifications

PHOX Motor Specifications								
Model	APMC-FAL01AM8N-8-AD	APMC-FAL01AM8N2-8-AD	APMC-FBL01AMK-8-AD	APMC-FBL01AMK2-8-AD	APMC-FBL02AMK-8-AD	APMC-FBL02AMK2-8-AD	APMC-FBL03AMK-8-AD	APMC-FBL03AMK2-8-AD
Price	\$267.00	\$460.00	\$210.00	\$386.00	\$248.00	\$434.00	\$305.00	\$495.00
Drawing	PDF	PDF	PDF	PDF	PDF	PDF	PDF	PDF
Input Voltage	24-80 VDC							
Drive Compatibility	PHOX-03-080NS-AD				PHOX-06-080NS-AD			
Integrated Brake	N	Y	N	Y	N	Y	N	Y
Flange Size (mm)	40			60				
Rated Power [W]	100W		100W		200W		300W	
Rated Torque [N·m] ^{Note 1}	0.32		0.32		0.64		0.95	
Max. Torque [N·m]	0.96		0.96		1.92		2.54	
Rated Speed [rpm]	3000							
Max. Speed [rpm]	3300							
Rated current [Amps] rms	2.71		2.5		5.54		6.79	
Max. Instantaneous Current [Amps] rms	8.13		7.50		16.62		18.0	
Rated Power Rate [kW/s]	24.24		11.13		27.57		36.81	
Rotor Inertia [$\times 10^{-4}$ kg m ²]	0.042		0.091		0.147		0.248	
Allowable Load Inertia Ratio	30 times motor inertia			20 times motor inertia				
Speed/Position Detector	Serial multi-turn built-in encoder (18-bit)			Serial multi-turn built-in encoder (19-bit)				
Protection	Fully enclosed self cooling IP67 ¹							
Rated Time	Continuous							
Ambient Temperature	Operating		0 to 40°C (32 to 104°F)					
	Storage		-10 to 60°C (14 to 140°F)					
Ambient Humidity	Operating		Below 80% relative humidity					
	Storage		Below 90% relative humidity (non-condensing)					
Atmosphere	Avoid direct sunlight and corrosive/flammable gas or liquid							
Vibration Resistance	Vibration acceleration 49m/s ² (5G)							
Weight [kg]	0.45	0.45	0.56	0.56	0.74	0.74	1.06	1.06

Note 1—Axis penetration not included. The IP rating for attached reducers is not guaranteed. Cables may not qualify marked IP rating if bent beyond designated specifications. Use specific cables for IP rating qualification.

Accessories

CN1 Accessories

For PHOX series drives, two methods are available for creating I/O connections.

Option 1:

Terminal blocks + cables:

- [APCS-PHOX-IOT-AD](#)
- [APCS-PHOX-IOT01-AD](#)
- [APCS-PHOX-IOT015-AD](#)
- [APCS-PHOX-IOT02-AD](#)

APCS-PHOX-IOT terminals ship with a universal labeling strip (A1-A13, B1-B13). A labeling template with designations specifically for the PHOX drive can be downloaded from any of the drive pages or the terminal block page (www.automationdirect.com/pn/apcs-phox-iot-ad).



[APCS-PHOX-IOT01-AD](#)

Option 2:

Flying lead cables:

- [APCS-PHOX-IO01A-AD](#)
- [APCS-PHOX-IO02A-AD](#)
- [APCS-PHOX-IO03A-AD](#)



[APCS-PHOX-IO03A-AD](#)

Part Number	Price	Description	Cable Length	Drawing	Compatible Drives
APCS-PHOX-IOT-AD	\$126.00	LS Electric CN1 feedthrough terminal block, 26-pole, DIN rail mount. For use with all LS Electric PHOX series drives. Control cable included.	0.5 m [1.6 ft]	PDF	All PHOX drives
APCS-PHOX-IOT01-AD	\$131.00		1.0 m [3.2 ft]	PDF	
APCS-PHOX-IOT015-AD	\$136.00		1.5 m [4.9 ft]	PDF	
APCS-PHOX-IOT02-AD	\$139.00		2.0 m [6.5 ft]	PDF	
APCS-PHOX-IO01A-AD	\$83.00	LS Electric control cable, 26-pin connector to pigtail.	1.0 m [3.2 ft]	PDF	
APCS-PHOX-IO02A-AD	\$87.00		2.0 m [6.5 ft]	PDF	
APCS-PHOX-IO03A-AD	\$91.00		3.0 m [9.8 ft]	PDF	

Accessories

PHOX Terminal Assignment Table



CAUTION: This terminal assignment table is for use with PHOX drives ONLY. Using this table with non-PHOX series drives could damage your equipment as terminal assignments are different for each drive series.

APCS-PHOX-IOTxx-AD

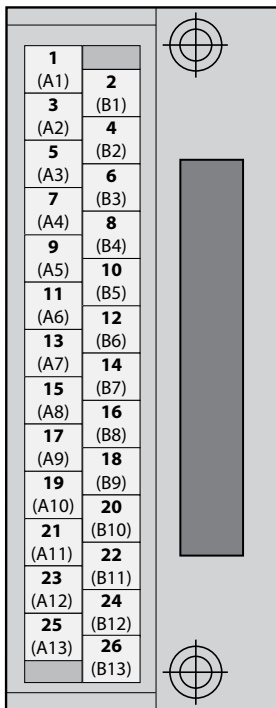

You can download a printable terminal label at <https://www.automationdirect.com/pn/apcs-phox-iot-ad>

PHOX Drive Terminal Assignments

Terminal	Drive I/O Pin/Wire #	Description	Wire Color	Number of Stripes
A1	1	PF+	Orange/Black Stripe	1
B1	2	PF-	Orange/Red Stripe	1
A2	3	PR+	Orange/Black Stripe	2
B2	4	PR-	Orange/Red Stripe	2
A3	5	AGND	Orange/Black Stripe	3
B3	6	AI+	Orange/Red Stripe	3
A4	7	AI-	Orange/Black Stripe	4
B4	8	AMON1	Orange/Red Stripe	4
A5	9	AMON2	Orange/Black Stripe	5
B5	10	DICOM Input Power	Orange/Red Stripe	5
A6	11	DI1	Yellow/Black Stripe	1
B6	12	DI2	Yellow/Red Stripe	1
A7	13	DI3	Yellow/Black Stripe	2
B7	14	DI4	Yellow/Red Stripe	2
A8	15	DO1	Yellow/Black Stripe	3
B8	16	DO2	Yellow/Red Stripe	3
A9	17	DO3	Yellow/Black Stripe	4
B9	18	DO4	Yellow/Red Stripe	4
A10	19	AO	Yellow/Black Stripe	5
B10	20	/AO	Yellow/Red Stripe	5
A11	21	BO	White/Black Stripe	1
B11	22	/BO	White/Red Stripe	1
A12	23	ZO	White/Black Stripe	2
B12	24	/ZO	White/Red Stripe	2
A13	25	DOCOM Common GND	White/Black Stripe	3
B13	26	AGND	White/Red Stripe	3

Accessories, *continued*

NOTE: These parts available for sale to North American locations only

PHOX System STO Cables

Use these pre-made factory cables to easily connect the drive STO connector to a safety relay.

Part Number	Price	Length	Description	Drawing	Compatible Motors
APCS-PHOX-STO03A-AD	\$23.00	0.3 m [1ft]	LS Electric STO cable, 6-pin connector to pigtail,	PDF	All PHOX series drives
APCS-PHOX-STO10A-AD	\$25.00	1m [3.2 ft]		PDF	
APCS-PHOX-STO30A-AD	\$28.00	3m [9.8 ft]		PDF	



APCS-PHOX-STO series cable

Accessories, continued

NOTE: These parts available for sale to North American locations only

PHOX System Motor Encoder Cables

Part Number	Price	Flex Rated	Length	Gauge	Drawing	Compatible Motors
APCV-EN03ES1-AD	\$107.00	N	3m [9.8 ft]	24AWG	PDF	All PHOX APMC motors
APCV-EN05ES1-AD	\$114.00		5m [16.4 ft]		PDF	
APCV-EN10ES1-AD	\$127.00		10m [32.8 ft]		PDF	
APCV-EN20ES1-AD	\$159.00		20m [65.6 ft]		PDF	
APCV-EF03ES1-AD	\$117.00	Y	3m [9.8 ft]		PDF	
APCV-EF05ES1-AD	\$127.00		5m [16.4 ft]		PDF	
APCV-EF10ES1-AD	\$159.00		10m [32.8 ft]		PDF	
APCV-EF20ES1-AD	\$221.00		20m [65.6 ft]		PDF	



APCV-EN series encoder cable

PHOX System Motor Power Cables

Part Number	Price	Flex Rated	Length	Gauge	Drawing	Compatible Motors
APCV-PN03LS-AD	\$48.00	N	3m [9.8 ft]	24AWG	PDF	All PHOX APMC motors
APCV-PN05LS-AD	\$53.00		5m [16.4 ft]		PDF	
APCV-PN10LS-AD	\$67.00		10m [32.8 ft]		PDF	
APCV-PN20LS-AD	\$94.00		20m [65.6 ft]		PDF	
APCV-PF03LS-AD	\$56.00	Y	3m [9.8 ft]		PDF	
APCV-PF05LS-AD	\$67.00		5m [16.4 ft]		PDF	
APCV-PF10LS-AD	\$95.00		10m [32.8 ft]		PDF	
APCV-PF20LS-AD	\$147.00		20m [65.6 ft]		PDF	



APCV-PN series power cable

PHOX System Motor Brake Cables

Part Number	Price	Flex Rated	Length	Gauge	Drawing	Compatible Motors
APCV-BN03QS-AD	\$48.00	N	3m [9.8 ft]	24AWG	PDF	All PHOX APMC motors
APCV-BN05QS-AD	\$52.00		5m [16.4 ft]		PDF	
APCV-BN10QS-AD	\$57.00		10m [32.8 ft]		PDF	
APCV-BN20QS-AD	\$72.00		20m [65.6 ft]		PDF	
APCV-BF03QS-AD	\$53.00	Y	3m [9.8 ft]		PDF	
APCV-BF05QS-AD	\$58.00		5m [16.4 ft]		PDF	
APCV-BF10QS-AD	\$73.00		10m [32.8 ft]		PDF	
APCV-BF20QS-AD	\$102.00		20m [65.6 ft]		PDF	







APCV-BN series brake cable

Note: Each brake cable consists of 4 wires: 24VDC and Common (input to the drive), and BRK+ and BRK- output to the motor brake.

Accessories, continued

PHOX Drive Replacement Connectors

Part Number	Price	Description	Compatible Drives	Image
<u>PHOX-CON-A</u>	\$15.00	AutomationDirect drive power connector, replacement, 8-pin. For use with all LS Electric PHOX series drives.	All LS Electric PHOX Drives	
<u>PHOX-CON-B</u>	\$5.00	AutomationDirect drive STO connector, replacement, 6-pin. For use with all LS Electric PHOX series drives. Requires PHOX-CON-D drive STO/brake crimp pins.		
<u>PHOX-CON-C</u>	\$5.00	AutomationDirect drive brake connector, replacement, 4-pin. For use with all LS Electric PHOX series drives. Requires PHOX-CON-D drive STO/brake crimp pins.		
<u>PHOX-CON-D</u>	\$9.00	AutomationDirect drive STO/brake crimp pins, replacement. Package of 10. For use with all LS Electric PHOX series drives.		
<u>PHOX-CON-E</u>	\$10.00	AutomationDirect drive encoder connector, 15-pin. For use with all LS Electric PHOX series drives. PHOX-CON-E gender changer allows easy wiring of Encoder Port B to an external encoder using ZL-HD15M-CBL-DB15F (with ZIPlink ZL-RTB-DB15 breakout module) or ZL-HD15M-CBL-2P HD15 (with flying leads).		



LS Electric AC Servo Systems

Drive Software

Drive CM Configuration Software

Drive CM is an optional free downloadable configuration software package for LS Electric servo drives. A PC may be directly connected to the servo drive via any standard USB-A to USB mini-B cable (SV2-PGM-USB15 or SV2-PGM-USB30 recommended).

Features

- Easy-to-use setup wizard guides you through the most common setup functions.
- Digital I/O / Jog Control allows the user to operate the servo system from the PC. This allows the servo to perform some basic motion and check the I/O during startup.
- Parameter Object editor for setting up all drive parameters.
- Tune and check the servo response in real-time using the scope feature.
- Upload and download the drive configuration. Save the drive configuration as a file for backup or future use.
- Edit the drive configuration.
- View all drive faults.
- View drive variable trends in real-time.
- (L7P/L7C series only) Set up 64 internal Indexes (point-to-point moves) that can be triggered by digital inputs or serial communications. Indexes can repeat and can initiate another Index when one move completes.

Download

Download the Drive CM software from AutomationDirect's LS Electric support page:

<https://support.automationdirect.com/products/lselectric.html>

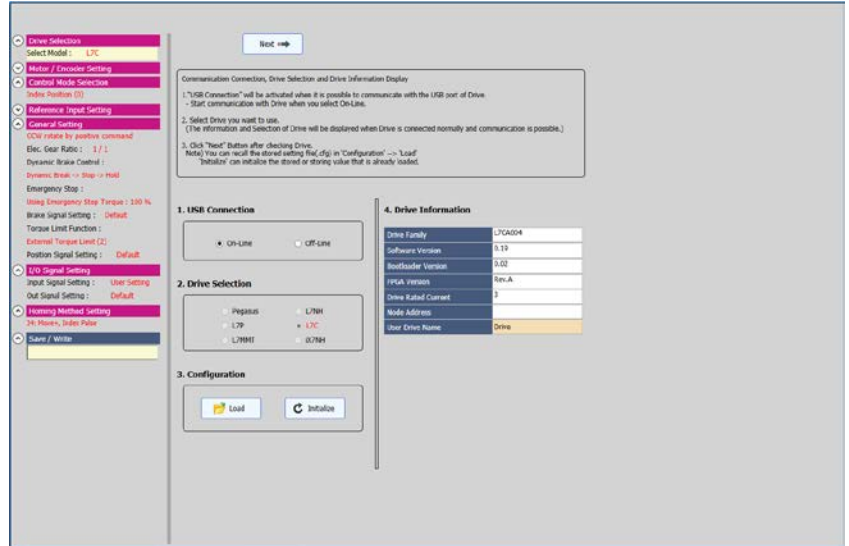

Setup Wizard Screen

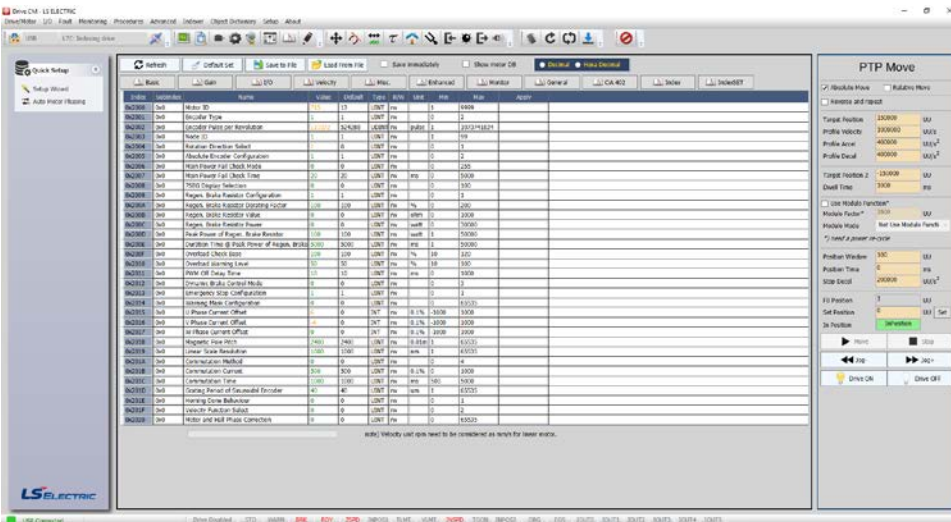

Drive CM Software Interface

Parameter Object Editor

The Drive CM configuration tool logically organizes all servo drive object parameters for viewing and editing using the Object Dictionary screen. Each parameter has a factory default that usually allows the servo to run "out-of-the-box".

The parameters can be easily changed with available setting ranges displayed. Tuning modes and parameters can also be changed using Drive CM. After the parameters have been defined, the complete setup can be stored and archived. Drive configurations can be uploaded, edited, saved, and downloaded as often as necessary.

Using the Drive CM software you can also configure and commission your drive without having to be connected to the master controller.



LS Electric AC Servo Systems

Drive Software, *continued*

Digital I/O, Jog Control, and Scope

The Digital I/O / Jog Control screen allows the user to operate the servo system from the PC. This is a great aid during start-up to allow the servo to perform some basic motion and to check the I/O.

Drive CM also includes a powerful scope function that allows the user to have as many as four channels of data displayed simultaneously. Each channel has a drop-down table to select the data to be displayed. The scope has the ability to save traces to a file and load those traces for offline review/analysis. This function is a valuable tool for tuning LS Electric servo drives.

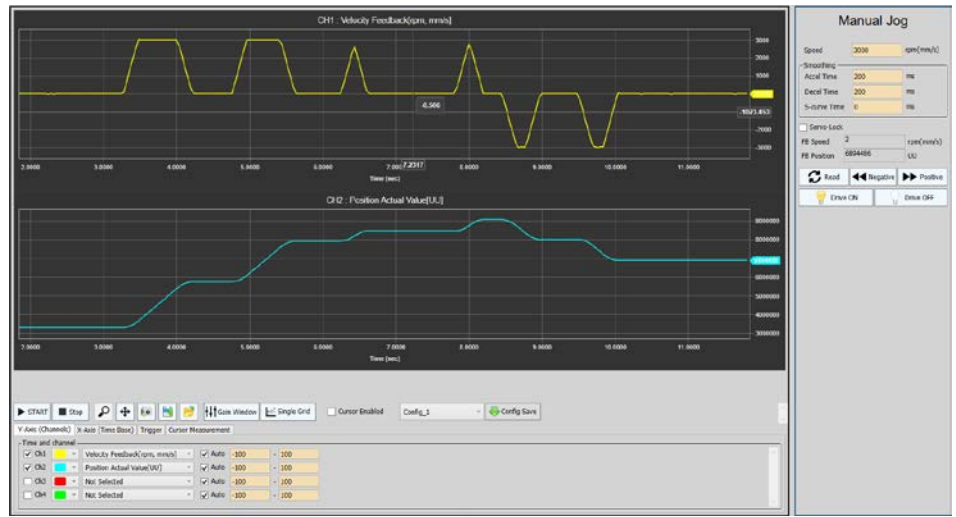

Jog Control / Scope Screen

General Setup Screen

Alarm History Screen

Indexer Setting Screen (L7P/L7C series only)

Object Dictionary Screen

LS ELECTRIC AC Servo Systems Accessories

Servo System EMI Filters

Input EMI filters reduce electromagnetic interference or noise on the input side of the servo drive. They are required for CE compliance and recommended for installations prone to or sensitive to electromagnetic interference.

Part Number	Price	Rating	Description	Drawing	Compatible Drive Series	Compatible Drive Models
<u>TB1-10A0D0</u>	\$67.00	10A	LS Electric EMI input filter, 250 VAC, 1-phase, 10A, panel mount, EMI/RFI filtering, 2-stage, drive rated, standard performance, screw terminals. For use with 1-phase AC drives.	<u>PDF</u>	All L7C series drives	L7CA004U-AD L7CA010U-AD
<u>TB6-B010LBEI</u>	\$86.00	10A	LS Electric EMI input filter, 550VAC, 3-phase, panel mount, EMI/RFI filtering, drive rated, standard performance, screw terminals.	<u>PDF</u>	L7P and iX7NH 400W through 1kW drives	L7PA004U-AD L7PA010U-AD L7PB010U-AD IX7NHA004U-AD IX7NHA008U-AD IX7NHA010U-AD
<u>TB6-B020NBDC</u>	\$110.00	20A		<u>PDF</u>	L7P 460V 2kW and 3.5 kW drives	L7PB020U-AD L7PB035U-AD
<u>TB6-B030NBDC</u>	\$104.00	30A		<u>PDF</u>	L7P and iX7NH 230V: 2kW, 3.5 kW and L7P 460V: 5kW	L7PA020U-AD L7PA035U-AD L7PB050U-AD IX7NHA020U-AD IX7NHA035U-AD
<u>TB6-B040AS</u>	\$180.00	40A		<u>PDF</u>	L7P 230V: 5kW 460V: 7.5 kW	L7PA050U-AD L7PB075U-AD
<u>TB6-B060LAS</u>	\$313.00	50A		<u>PDF</u>	L7P 230V: 7.5 kW drives	L7PA075U-AD



TB1-10A0D0



TB6-B010LBEI

Accessories, continued

NOTE: These parts available for sale to North American locations only

L7C/L7P/iX7NH/PHOX System Planetary Gearboxes

Precision planetary gearboxes can increase the torque output of servo systems while reducing the reflected load inertia for higher response. Gearboxes offer high stiffness, high efficiency, and very quiet operation. Input motor shaft clamp, oversized output shaft key, and mounting hardware are included for mating to LS Electric motors.

Features:

- Maintenance free (no need to replace lubrication)
- IP65
- Operating temperature range of -10°C to +90°C [14°F to 194°F]
- Uses VIGO Grease RE #0



MSS Series Planetary Gearbox

MSS Series Planetary Gearbox Specifications										
Model	96200004	96200005	96200103	96200007	96200008	96200257	96200373	96200378	96200393	96200459
Manufacturer Part Number	MSS0601A-005KS-B3110103C14	MSS0601A-010KS-B3110103C14	MSS0902B-020KS-B3110103C14	MSS0901A-005KS-C3110103C19	MSS0901A-010KS-C3110103C19	MSS1152B-020KS-C4120103C19	MSS0901A-005KS-C4120103C19	MSS0901A-010KS-C4120103C19	MSS1152B-020KS-C4120103C19	MSS1151A-005KS-D3110103C22
Compatible Motors	APMC-FBL series 100, 200, 300, and 400 W motors			APMC FCL series 750W and 1kW motors			APM-FE series 900W and 1.5 kW motors			APM-FE series 1.6 kW motors
Price	\$288.00	\$296.00	\$528.00	\$387.00	\$387.00	\$762.00	\$350.00	\$350.00	\$699.00	\$499.00
Drawing	PDF	PDF	PDF	PDF	PDF	PDF	PDF	PDF	PDF	PDF
Ratio	5:1	10:1	20:1	5:1	10:1	20:1	5:1	10:1	20:1	5:1
Nominal Output Torque	54 N·m	42 N·m	143 N·m	160 N·m	121 N·m	295 N·m	160 N·m	121 N·m	295 N·m	332 N·m
Inertia	0.13 kg/cm ²	0.13 kg/cm ²	0.13 kg/cm ²	0.48 kg/cm ²	0.44 kg/cm ²	0.48 kg/cm ²	0.48 kg/cm ²	0.44 kg/cm ²	0.48 kg/cm ²	2.81 kg/cm ²
Output Shaft Diameter	16mm	16mm	22mm	22mm	22mm	32mm	22mm	22mm	32mm	32mm
Stage	1	1	2	1	1	2	1	1	2	1
Frame	60mm	60mm	90mm	90mm	90mm	115mm	90mm	90mm	115mm	115mm
Nominal Input Speed (rpm)	5,000	5,000	4,000	4,000	4,000	4,000	4,000	4,000	4,000	4,000
Max Input Speed (rpm)	10,000	10,000	8,000	8,000	8,000	8,000	8,000	8,000	8,000	8,000
Emergency Stop Torque	3 times nominal output torque									
Noise (dB)	≤54	≤54	≤56	≤56	≤56	≤59	≤56	≤56	≤59	≤59
Efficiency (%)	≥97	≥97	≥94	≥97	≥97	≥94	≥97	≥97	≥94	≥97
Backlash (Arcmin)	≤7	≤7	≤9	≤7	≤7	≤9	≤7	≤7	≤9	≤7
Max Radial Load (N)	1,280	1,280	3,200	3,200	3,200	6,800	3,200	3,200	6,800	6,800
Max Axial Load (N)	690	690	1,600	1,600	1,600	3,400	1,600	1,600	3,400	3,400
Service Life (Hours)	20,000 (10,000 under continuous operation)									
Continued on next page										



LS Electric AC Servo Systems

Accessories, continued

MSS Series Planetary Gearbox Specifications											
Model	96200464	96200479	96200010	96200011	96200445	96200013	96200014	96200701	96200016	96200017	96200862
Manufacturer Part Number	MSS1151A-010KS-D3110103C22	MSS1422B-020KS-D3110103C22	MSS1151A-005KS-D3110103C24	MSS1151A-010KS-D3110103C24	MSS1422B-020KS-D3110103C24	MSS1421A-005KS-E3110103C35	MSS1421A-010KS-E3110103C35	MSS1802B-020KS-E3110103C35	MSS1801A-005KS-F3110103C42	MSS1801A-010KS-F3110103C42	MSS1802A-015KS-F3110103C42
Compatible Motors	APM-FE series 1.6 kW motors		APM-FE series 2.2 kW motors			APM-FF series 3.5 kW and 5.5 kW motors			APM-FF series 7.5 kW motors		
Price	\$499.00	\$1,030.00	\$499.00	\$499.00	\$1,030.00	\$770.00	\$770.00	\$1,850.00	\$1,480.00	\$1,480.00	\$1,850.00
Drawing	PDF	PDF	PDF	PDF	PDF	PDF	PDF	PDF	PDF	PDF	PDF
Ratio	10:1	20:1	5:1	10:1	20:1	5:1	10:1	20:1	5:1	10:1	15:1
Nominal Output Torque	262 N·m	295 N·m	332 N·m	262 N·m	295 N·m	634 N·m	500 N·m	1060 N·m	1195 N·m	960 N·m	897 N·m
Inertia	2.59 kg/cm ²	2.81 kg/cm ²	2.81 kg/cm ²	2.59 kg/cm ²	2.81 kg/cm ²	7.52 kg/cm ²	7.05 kg/cm ²	7.52 kg/cm ²	24.29 kg/cm ²	23.51 kg/cm ²	24.29 kg/cm ²
Output Shaft Diameter	32mm	40mm	32mm	32mm	40mm	40mm	40mm	55mm	55mm	55mm	55mm
Stage	1	2	1	1	2	1	1	2	1	1	2
Frame	115mm	142mm	115mm	115mm	142mm	142mm	142mm	180mm	180mm	180mm	180mm
Nominal Input Speed (rpm)	4,000	3,000	4,000	4,000	3,000	3,000	3,000	3,000	3,000	3,000	3,000
Max Input Speed (rpm)	8,000	6,000	8,000	8,000	6,000	6,000	6,000	6,000	6,000	6,000	6,000
Emergency Stop Torque	3 times nominal output torque										
Noise (dB)	≤59	≤62	≤59	≤59	≤62	≤62	≤62	≤64	≤64	≤64	≤64
Efficiency (%)	≥97	≥94	≥97	≥97	≥94	≥97	≥97	≥94	≥97	≥97	≥94
Backlash (Arcmin)	≤7	≤9	≤7	≤7	≤9	≤7	≤7	≤9	≤7	≤7	≤9
Max Radial Load (N)	6,800	9,300	6,800	6,800	9,300	9,300	9,300	15,100	15,100	15,100	15,100
Max Axial Load (N)	3,400	4,500	3,400	3,400	4,500	4,500	4,500	7,500	7,500	7,500	7,500
Service Life (Hours)	20,000 (10,000 under continuous operation)										

Precision Servo Gearboxes

SureGear® Servo Gearbox Overview

PGA In-line Series

The SureGear PGA series of high-precision servo gear reducers is an excellent choice for applications that require good accuracy and reliability at an exceptional value. This in-line planetary gear reducer has a thread-in mounting style, along with a level of precision and torque capacity that is best in its class. Offered in a concentric shaft design with a maximum seven arc-min backlash rating, the SureGear PGA series is an accurate, high-performance, and cost effective solution for any OEM.

The machining quality of the SureGear PGA helical planetary gears provides a very quiet and more efficient reducer than other competitive products that are similarly priced. The SureGear PGA series easily mates to SureServo motors, and is the perfect solution for applications such as gantries, injection-molding machines, pick-and-place automation, and linear slides.

PGB Right-angle Series

The SureGear PGB series of high-precision right-angle servo gear reducers is an excellent choice for applications that require a more compact footprint.

The PGB right-angle planetary gear reducers offer similar technical specifications to the PGA series in-line gear reducers, and provides the customer with an excellent solution when space and clearance requirements are limited.

Offered with a six arc-min backlash rating for 2-stage and nine arc-min backlash for 3-stage, the SureGear PGB series performs to OEMs' demanding expectations.

PGD Hub Style In-line Series

The SureGear PGD series sets a new standard in applications requiring extremely high-torque ratings and rigidity. The compact design and hub-style output is ideal for equipment that requires high-speed, high-precision indexing movement. The remarkable torsion stiffness and the low backlash of the planetary gearing combine to provide outstanding positioning accuracy.

With a backlash rating less than 3 arc-minutes and exceptional torque handling capabilities, the PGD series offers a high performance robust planetary solution for OEM customers. The PGD reducer is often used for larger indexing applications and dial tables commonly found in packaging and filling equipment and assembly automation systems.

Features

- Thread-in mounting style
- Best-in-class backlash
- Four gear ratios available (5:1, 10:1, 15:1, 25:1), Two additional for PGD models (35:1 and 50:1)
- Mounting hardware included for attaching to SureServo motors
- Helical-cut planetary gears for quiet operation and reduced vibration
- Right-angle reducer utilizes a spiral bevel gear; motor can be located at a 90° position from the reducer, providing a more compact footprint
- Uncaged needle roller bearings for high rigidity and torque
- Adapter bushing connection for simple and effective attachment to most servo motors
- High-viscosity, anti-separation grease does not migrate away from the gears; no leakage through the seal
- Maintenance free: No need to replace the grease for the life of the unit
- At nominal speed, service life is 20,000 hours
- Can be positioned in any orientation
- IP55 environmental rating
- 5-year warranty



**SureGear
PGA Gearbox**



SureGear PGB Gearbox



**SureGear
Hub Style PGD Gearbox**



**SureGear
2-Stage Cutaway View**

Applications

- Gantries
- Injection-molding machines
- Pick-and-place automation
- Linear slides
- Packaging machines
- Conveyors



Precision Servo Gearboxes

SureGear® Servo Gearbox Selection													
Servo Motor	Gear Ratio	SureGear Gearbox	Frame Size (mm)	Motor Nominal Output Torque		Combo Nominal Output Torque		Nominal Output Speed (rpm)	Max Output Speed (rpm)	Available Load Inertia @ 5:1 Mismatch *			
				N-m	lb-in	N-m	lb-in			kg-cm2	lb-in-s2		
SV2L-201(x) APMC-FAL01xxx	5:1	PGD047-05A1	47	0.32	2.83	1.52	13.44	600	1200.00	6.76	0.006		
		PGA050-05A1	50							6.94	0.006		
		PGA070-05A1	70							5.91	0.005		
		PGB070-05A1	70							1.59**	0.001**		
	10:1	PGD047-10A1	47			3.04	26.89			300	600.00	28.15	0.025
		PGA050-10A1	50									28.35	0.025
		PGA070-10A1	70									25.75	0.023
		PGB070-10A1	70									8.35**	0.007**
	15:1	PGA050-15A1	50			4.32	38.21	200	400.00	62.66	0.055		
		PGA070-15A1	70							58.16	0.051		
		PGB070-15A1	70							54.11	0.048		
	25:1	PGD047-25A1	47			7.20	63.68			120	240.00	174.69	0.155
		PGA050-25A1	50									174.69	0.155
		PGA070-25A1	70									162.81	0.144
		PGB070-25A1	70					7.04	62.26			151.56	0.134
	50:1	PGD064-50A1	64			14.40	127.35	60	120.00	661.25	0.585		
SV2L-202(x)	5:1	PGD064-05A2	64	0.64	5.7	3.04	27.08	600	1200.00	28.75	0.025		
		PGA070-05A2	70							29.33	0.026		
		PGB070-05A2	70							2.98	26.51	25.00	0.022
	10:1	PGD064-10A2	64			6.08	54.15			300	600.00	118.80	0.105
		PGA070-10A2	70									119.40	0.106
		PGB070-10A2	70									5.95	53.01
	15:1	PGA070-15A2	70			8.64	76.95	200	400.00	268.88	0.238		
		PGB070-15A2	70							8.45	75.24	264.83	0.234
		PGB090-15A2	90							204.75	0.181		
	25:1	PGD064-25A2	64			14.40	128.25	120	240.00	747.50	0.662		
		PGA070-25A2	70							748.13	0.662		
		PGB070-25A2	70							14.08	125.40	736.88	0.652
		PGB090-25A2	90							581.25	0.514		
		PGD090-25A2	90							14.40	128.25	700.00	0.620
	50:1	PGD090-50A2	90			28.80	256.50	60	120.00	2875.00	2.544		
		PGD110-50A2	110							2125.00	1.881		
SV2L-204(x)	5:1	PGD064-05A2	64	1.27	11.2	6.03	53.20	600	1200.00	53.75	0.048		
		PGA070-05A2	70							54.33	0.048		
		PGB070-05A2	70							5.91	52.08	50.00	0.044
	10:1	PGD064-10A2	64			12.07	106.40			300	600.00	218.80	0.194
		PGA070-10A2	70									219.40	0.194
		PGB070-10A2	70									11.81	104.16
	15:1	PGA070-15A2	70			17.15	151.20	200	400.00	493.88	0.437		
		PGB070-15A2	70							16.76	147.84	489.83	0.433
		PGB090-15A2	90							429.75	0.380		
	25:1	PGD064-25A2	64			28.58	252.00	120	240.00	1372.50	1.215		
		PGA070-25A2	70							1373.13	1.215		
		PGB070-25A2	70							27.94	246.40	1361.88	1.205
		PGB090-25A2	90							1206.25	1.068		
		PGD090-25A2	90							28.58	252.00	1325.00	1.173
	50:1	PGD090-50A2	90			57.15	504.00	60	120.00	5375.00	4.757		
		PGD110-50A2	110							4625.00	4.093		

* Available load inertia is calculated based on servo motor inertia using the formula: Available Inertia = (5 x Motor Inertia – Gearbox Inertia) x (Gear Ratio)² A 5:1 inertia mismatch is a good target for design purposes. Systems with lower or higher mismatch may be possible, depending on operating conditions.

** This gearbox is NOT a suitable choice at a 5:1 mismatch. If inertia balancing is a selection criteria for your end use, please use a mismatch of 8:1 to 10:1.