



# PBC Linear Shafts and Shaft Supports

## PBC Linear Simplicity® 60 Plus Linear Shaft Features

- Optimized surface finish for plain and ball bearings
- Straightness: 0.001"–0.002" per ft cumulative
- Length Tolerance: ±0.030"
- Surface Finish: 8-12Ra
- Hardness:
  - RC60-65 for 1060 Steel
  - RC50-55 for 440C Stainless Steel



In most applications, smoother is not better; in fact it means decreased performance and shortened life. PBC Linear has engineered the surface finish for optimum performance

| PBC Linear Shafts (1060 Carbon Steel) |         |                  |         |            |                     |
|---------------------------------------|---------|------------------|---------|------------|---------------------|
| Part Number                           | Price   | Nominal Diameter | Length  | Material   | Drawing Links       |
| <a href="#">NIL04-006.000-SL</a>      | \$4.50  | 1/4in            | 6.0 in  | 1060 steel | <a href="#">PDF</a> |
| <a href="#">NIL04-012.000-SL</a>      | \$9.00  |                  | 12.0 in |            | <a href="#">PDF</a> |
| <a href="#">NIL06-006.000-SL</a>      | \$5.00  | 3/8in            | 6.0 in  |            | <a href="#">PDF</a> |
| <a href="#">NIL06-012.000-SL</a>      | \$10.00 |                  | 12.0 in |            | <a href="#">PDF</a> |
| <a href="#">NIL06-018.000-SL</a>      | \$15.00 | 1/2in            | 18.0 in |            | <a href="#">PDF</a> |
| <a href="#">NIL08-012.000-SL</a>      | \$10.50 |                  | 12.0 in |            | <a href="#">PDF</a> |
| <a href="#">NIL08-024.000-SL</a>      | \$21.00 | 5/8in            | 24.0 in |            | <a href="#">PDF</a> |
| <a href="#">NIL08-036.000-SL</a>      | \$32.00 |                  | 36.0 in |            | <a href="#">PDF</a> |
| <a href="#">NIL10-012.000-SL</a>      | \$13.00 | 3/4in            | 12.0 in |            | <a href="#">PDF</a> |
| <a href="#">NIL10-024.000-SL</a>      | \$26.00 |                  | 24.0 in |            | <a href="#">PDF</a> |
| <a href="#">NIL10-036.000-SL</a>      | \$39.00 | 1in              | 36.0 in |            | <a href="#">PDF</a> |
| <a href="#">NIL12-012.000-SL</a>      | \$17.00 |                  | 12.0 in |            | <a href="#">PDF</a> |
| <a href="#">NIL12-024.000-SL</a>      | \$34.00 | 1-1/4in          | 24.0 in |            | <a href="#">PDF</a> |
| <a href="#">NIL12-036.000-SL</a>      | \$51.00 |                  | 36.0 in |            | <a href="#">PDF</a> |
| <a href="#">NIL16-012.000-SL</a>      | \$23.00 | 1-1/4in          | 12.0 in |            | <a href="#">PDF</a> |
| <a href="#">NIL16-024.000-SL</a>      | \$46.00 |                  | 24.0 in |            | <a href="#">PDF</a> |
| <a href="#">NIL16-036.000-SL</a>      | \$68.00 | 1-1/4in          | 36.0 in |            | <a href="#">PDF</a> |
| <a href="#">NIL20-012.000-SL</a>      | \$29.00 |                  | 12.0 in |            | <a href="#">PDF</a> |
| <a href="#">NIL20-024.000-SL</a>      | \$58.00 | 1-1/4in          | 24.0 in |            | <a href="#">PDF</a> |
| <a href="#">NIL20-036.000-SL</a>      | \$88.00 |                  | 36.0 in |            | <a href="#">PDF</a> |

| PBC Linear Shafts (440C Stainless Steel) |          |                  |                     |                      |                     |
|--|----------|------------------|---------------------|----------------------|---------------------|
| Part Number                              | Price    | Nominal Diameter | Length              | Material             | Drawing Links       |
| <a href="#">NIL06SS-006.000-SL</a>       | \$13.25  | 3/8in            | 6.0 in              | 440C stainless steel | <a href="#">PDF</a> |
| <a href="#">NIL06SS-012.000-SL</a>       | \$26.50  |                  | 12.0 in             |                      | <a href="#">PDF</a> |
| <a href="#">NIL08SS-012.000-SL</a>       | \$25.00  | 1/2in            | 12.0 in             |                      | <a href="#">PDF</a> |
| <a href="#">NIL08SS-024.000-SL</a>       | \$50.00  |                  | 24.0 in             |                      | <a href="#">PDF</a> |
| <a href="#">NIL08SS-036.000-SL</a>       | \$97.00  | 5/8in            | 36.0 in             |                      | <a href="#">PDF</a> |
| <a href="#">NIL10SS-012.000-SL</a>       | \$32.00  |                  | 12.0 in             |                      | <a href="#">PDF</a> |
| <a href="#">NIL10SS-024.000-SL</a>       | \$64.00  | 3/4in            | 24.0 in             |                      | <a href="#">PDF</a> |
| <a href="#">NIL10SS-036.000-SL</a>       | \$97.00  |                  | 36.0 in             |                      | <a href="#">PDF</a> |
| <a href="#">NIL12SS-012.000-SL</a>       | \$35.50  | 1in              | 12.0 in             |                      | <a href="#">PDF</a> |
| <a href="#">NIL12SS-024.000-SL</a>       | \$71.00  |                  | 24.0 in             |                      | <a href="#">PDF</a> |
| <a href="#">NIL12SS-036.000-SL</a>       | \$140.00 | 1-1/4in          | 36.0 in             |                      | <a href="#">PDF</a> |
| <a href="#">NIL16SS-012.000-SL</a>       | \$50.00  |                  | 12.0 in             |                      | <a href="#">PDF</a> |
| <a href="#">NIL16SS-024.000-SL</a>       | \$100.00 | 1-1/4in          | 24.0 in             |                      | <a href="#">PDF</a> |
| <a href="#">NIL16SS-036.000-SL</a>       | \$150.00 |                  | 36.0 in             |                      | <a href="#">PDF</a> |
| <a href="#">NIL20SS-012.000-SL</a>       | \$55.00  | 1-1/4in          | 12.0 in             |                      | <a href="#">PDF</a> |
| <a href="#">NIL20SS-024.000-SL</a>       | \$110.00 |                  | 24.0 in             |                      | <a href="#">PDF</a> |
| <a href="#">NIL20SS-036.000-SL</a>       | \$165.00 | 36.0 in          | <a href="#">PDF</a> |                      |                     |

## PBC Linear Shaft Support Features

- End support blocks can be used for end or intermediate shaft support
- Instant bolt-down installation
- Lightweight and strong.
- Can be used with all shaft types.
- Should be used where deflection between supports is not a problem.
- Material: Aluminum with anodize finish
- Center height tolerance: +/- 0.001"



| PBC Shaft Support     |         |                  |               |                     |
|-----------------------|---------|------------------|---------------|---------------------|
| Part Number           | Price   | Nominal Diameter | Center Height | Drawing Links       |
| <a href="#">NSB04</a> | \$21.00 | 1/4 in           | 11/16 in      | <a href="#">PDF</a> |
| <a href="#">NSB06</a> | \$21.50 | 3/8 in           | 3/4 in        | <a href="#">PDF</a> |
| <a href="#">NSB08</a> | \$29.00 | 1/2 in           | 1 in          | <a href="#">PDF</a> |
| <a href="#">NSB10</a> | \$30.50 | 5/8 in           | 1 in          | <a href="#">PDF</a> |
| <a href="#">NSB12</a> | \$32.00 | 3/4 in           | 1-1/4 in      | <a href="#">PDF</a> |
| <a href="#">NSB16</a> | \$39.00 | 1 in             | 1-1/2 in      | <a href="#">PDF</a> |
| <a href="#">NSB20</a> | \$47.00 | 1-1/4 in         | 1-3/4 in      | <a href="#">PDF</a> |



# PBC Linear Supported Shafts

## PBC Linear Simplicity® 60 Plus Supported Linear Shaft Features

- Optimized surface finish for plain and ball bearings
- Straightness: 0.001"–0.002" per ft cumulative
- Length Tolerance: ±0.030"
- Surface Finish: 8-12Ra
- Hardness:
  - RC60-65 for 1060 Steel
  - RC50-55 for 440C Stainless Steel
- Shaft support material: Aluminum
- Centerline tolerance: ±0.002"



In most applications, smoother is not better; in fact it means decreased performance and shortened life. PBC Linear has engineered the surface finish for optimum performance

### PBC Supported Linear Shafts (1060 Carbon Steel)

| Part Number                      | Price    | Nominal Diameter | Length  | Material            | Drawing Links       |
|----------------------------------|----------|------------------|---------|---------------------|---------------------|
| <a href="#">SRA08-012.000-SL</a> | \$100.00 | 1/2in            | 12.0 in | 1060 steel          | <a href="#">PDF</a> |
| <a href="#">SRA08-024.000-SL</a> | \$205.00 |                  | 24.0 in |                     | <a href="#">PDF</a> |
| <a href="#">SRA08-036.000-SL</a> | \$310.00 |                  | 36.0 in |                     | <a href="#">PDF</a> |
| <a href="#">SRA10-012.000-SL</a> | \$115.00 | 5/8in            | 12.0 in |                     | <a href="#">PDF</a> |
| <a href="#">SRA10-024.000-SL</a> | \$221.00 |                  | 24.0 in |                     | <a href="#">PDF</a> |
| <a href="#">SRA10-036.000-SL</a> | \$340.00 |                  | 36.0 in |                     | <a href="#">PDF</a> |
| <a href="#">SRA12-012.000-SL</a> | \$123.00 | 3/4in            | 12.0 in |                     | <a href="#">PDF</a> |
| <a href="#">SRA12-024.000-SL</a> | \$252.00 |                  | 24.0 in |                     | <a href="#">PDF</a> |
| <a href="#">SRA12-036.000-SL</a> | \$360.00 |                  | 36.0 in |                     | <a href="#">PDF</a> |
| <a href="#">SRA16-012.000-SL</a> | \$153.00 | 1in              | 12.0 in |                     | <a href="#">PDF</a> |
| <a href="#">SRA16-024.000-SL</a> | \$305.00 |                  | 24.0 in |                     | <a href="#">PDF</a> |
| <a href="#">SRA16-036.000-SL</a> | \$460.00 |                  | 36.0 in |                     | <a href="#">PDF</a> |
| <a href="#">SRA20-012.000-SL</a> | \$170.00 | 1-1/4in          | 12.0 in | <a href="#">PDF</a> |                     |
| <a href="#">SRA20-024.000-SL</a> | \$360.00 |                  | 24.0 in | <a href="#">PDF</a> |                     |
| <a href="#">SRA20-036.000-SL</a> | \$510.00 |                  | 36.0 in | <a href="#">PDF</a> |                     |

### PBC Supported Linear Shafts (440C Stainless Steel)

| Part Number                        | Price    | Nominal Diameter | Length  | Material             | Drawing Links       |
|------------------------------------|----------|------------------|---------|----------------------|---------------------|
| <a href="#">SRA08SS-012.000-SL</a> | \$155.00 | 1/2in            | 12.0 in | 440C stainless steel | <a href="#">PDF</a> |
| <a href="#">SRA08SS-024.000-SL</a> | \$310.00 |                  | 24.0 in |                      | <a href="#">PDF</a> |
| <a href="#">SRA08SS-036.000-SL</a> | \$465.00 |                  | 36.0 in |                      | <a href="#">PDF</a> |
| <a href="#">SRA10SS-012.000-SL</a> | \$155.00 | 5/8in            | 12.0 in |                      | <a href="#">PDF</a> |
| <a href="#">SRA10SS-024.000-SL</a> | \$310.00 |                  | 24.0 in |                      | <a href="#">PDF</a> |
| <a href="#">SRA10SS-036.000-SL</a> | \$465.00 |                  | 36.0 in |                      | <a href="#">PDF</a> |
| <a href="#">SRA12SS-012.000-SL</a> | \$185.00 | 3/4in            | 12.0 in |                      | <a href="#">PDF</a> |
| <a href="#">SRA12SS-024.000-SL</a> | \$370.00 |                  | 24.0 in |                      | <a href="#">PDF</a> |
| <a href="#">SRA12SS-036.000-SL</a> | \$550.00 |                  | 36.0 in |                      | <a href="#">PDF</a> |
| <a href="#">SRA16SS-012.000-SL</a> | \$220.00 | 1in              | 12.0 in |                      | <a href="#">PDF</a> |
| <a href="#">SRA16SS-024.000-SL</a> | \$410.00 |                  | 24.0 in |                      | <a href="#">PDF</a> |
| <a href="#">SRA16SS-036.000-SL</a> | \$650.00 |                  | 36.0 in |                      | <a href="#">PDF</a> |
| <a href="#">SRA20SS-012.000-SL</a> | \$285.00 | 1-1/4in          | 12.0 in | <a href="#">PDF</a>  |                     |
| <a href="#">SRA20SS-024.000-SL</a> | \$570.00 |                  | 24.0 in | <a href="#">PDF</a>  |                     |
| <a href="#">SRA20SS-036.000-SL</a> | \$850.00 |                  | 36.0 in | <a href="#">PDF</a>  |                     |

## What is FrelonGOLD?

FrelonGOLD is a compound of Polyterafluoroethylene (PTFE) and fillers developed for improved performance over other bearings. They provide low wear, low friction, self-lubrication, and high strength.

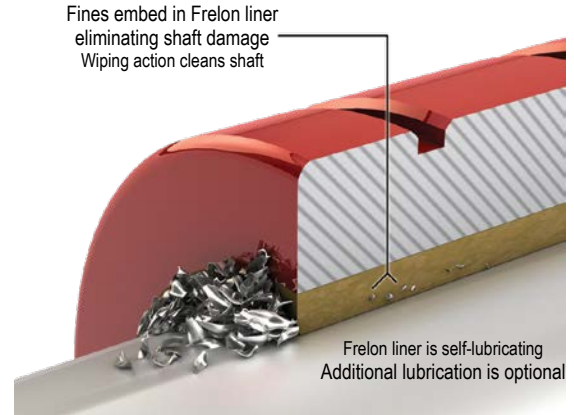
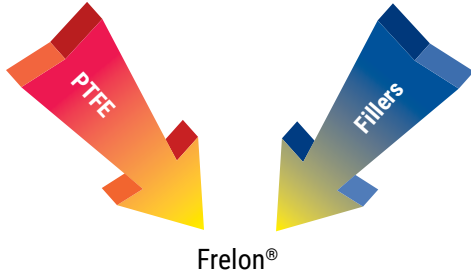

## Transfer Process of Liner to Shaft

The interaction of the Frelon<sup>®</sup> material and the shafting creates a natural, microscopic transfer of the Frelon to the running surface. A thin film is deposited on the shaft, and the valleys in the surface finish are filled in with Frelon material during the initial break-in period. This transfer creates the self-lubricating condition of Frelon riding on Frelon. This break-in period varies depending on several criteria:

1. Preparation of the shafting prior to installation – it is best to clean the shafting with a 3-in-1 type oil before installing the bearings. This ensures that the surface will receive a full transfer of material.
2. Speed, load, and length of stroke specific to the application – typically the initial transfer process will take approximately 50-100 strokes of continuous operation. The running clearance on the bearing will increase an average of 0.0002" to 0.0005", depending on the length of the stroke and surface requiring the transfer.
3. How often the shafting is cleaned – if the shafting is cleaned regularly, increased wear will be seen in the bearings. This is due to the transfer process being performed over and over again.

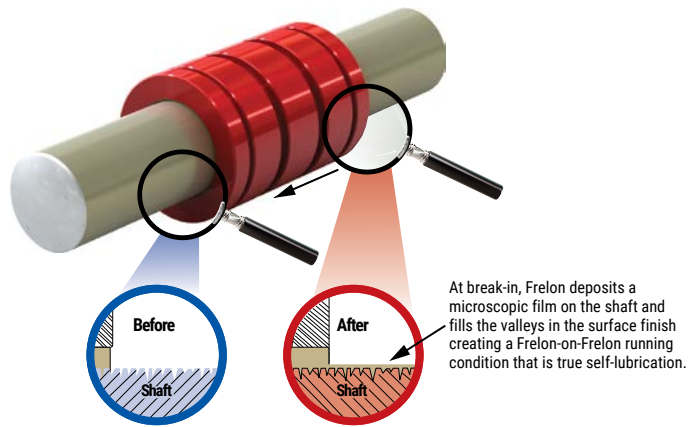

## Performance Ratings (for Linear Motion)

Plain bearings are rated by their limiting Pressure Velocity (PV), which is a combination of load over a given surface area and the velocity.

(-)C<sub>o</sub> = Static Load on bearing

A = Bearing effective surface area

V = velocity (speed) in ft/min (m/min.)

P = Pressure on Bearing = C<sub>o</sub>/A

PV = Pressure Velocity

| PV <sub>max</sub>                     | P <sub>max</sub>             | V <sub>max</sub>          |                             |                   |
|---------------------------------------|------------------------------|---------------------------|-----------------------------|-------------------|
|                                       |                              | No Lube Continuous Motion | No Lube Intermittent Motion | With Lubrication* |
| 20000<br>(psi x ft./min.)             | 3000<br>psi                  | 300 ft/min                | 825 ft/min                  | 825 ft/min        |
| 430<br>(kgf/cm <sup>2</sup> x m/min.) | 210.9<br>kgf/cm <sup>2</sup> | 1.524 m/sec.              | 4.19 m/sec.                 | 4.19 m/sec.       |

\*Depending on the lubrication used, loads, and frequency of continuous or intermittent motion, speeds can be in excess of the numbers shown.



FrelonGOLD not recommended for use with deionized water and other harsh chemicals. See the chemical reaction chart

### PV CHART (Dry Running)

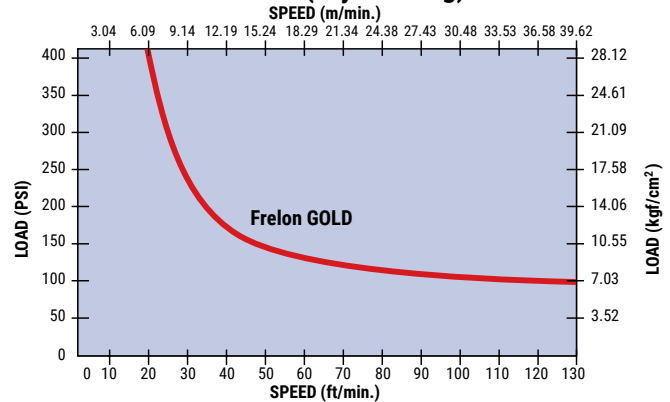

#### Recommended Lubricants:

- Waylube oil
- Light weight oils
- Petroleum based grease
- 3-in-1 oils

#### Not Recommended Lubricants:

- WD-40
- PTFE sprays
- Fluorocarbons
- Silicon oils

Prior to use, it is best to clean the rail with a 3-in-1 type oil before installing the carriages. This ensures that the surface will receive a full transfer of Frelon material during break-in



# PBC Simplicity<sup>®</sup> Plain Bearings

## PBC Linear Plain Bearing Features

- Class III Plain Bearing
- Self-lubricating
- Maintenance free
- Coefficient of friction: 0.125
- Temperature range: ± 400° F
- Bearing Liner Material: FrelonGOLD<sup>®</sup> (PTFE)
- Bearing Shell Material: Aluminum Alloy with anodized finish
- For Linear, oscillating, rotary motion, or combination of all 3



Closed Bearing



Open Bearing

| Simplicity Series Plain Bearings |         |            |                     |                            |                                |  |                     |
|----------------------------------|---------|------------|---------------------|----------------------------|--------------------------------|--|---------------------|
| Part Number                      | Price   | Nominal ID | Bearing Form Factor | Effective Surface Area (A) | Running Clearance (Both Sides) | Max Static Load Rating (C <sub>0</sub> ) | Drawing Links       |
| <a href="#">FL04</a>             | \$19.00 | 1/4 in     | closed              | 0.20 in <sup>2</sup>       | 0.0005 in                      | 600 lbs                                  | <a href="#">PDF</a> |
| <a href="#">FL06</a>             | \$21.00 | 3/8 in     |                     | 0.34 in <sup>2</sup>       |                                | 1020 lbs                                 | <a href="#">PDF</a> |
| <a href="#">FL08</a>             | \$22.00 | 1/2 in     |                     | 0.65 in <sup>2</sup>       |                                | 1950 lbs                                 | <a href="#">PDF</a> |
| <a href="#">FL10</a>             | \$24.50 | 5/8 in     |                     | 0.98 in <sup>2</sup>       |                                | 2940 lbs                                 | <a href="#">PDF</a> |
| <a href="#">FL12</a>             | \$25.00 | 3/4 in     |                     | 1.27 in <sup>2</sup>       |                                | 3810 lbs                                 | <a href="#">PDF</a> |
| <a href="#">FL16</a>             | \$46.00 | 1 in       |                     | 2.35 in <sup>2</sup>       |                                | 7050 lbs                                 | <a href="#">PDF</a> |
| <a href="#">FL20</a>             | \$77.00 | 1 1/4 in   |                     | 3.43 in <sup>2</sup>       |                                | 10830 lbs                                | <a href="#">PDF</a> |
| <a href="#">FLN08</a>            | \$29.00 | 1/2 in     | open                | 0.65 in <sup>2</sup>       | 0.0015 in                      | 1950 lbs                                 | <a href="#">PDF</a> |
| <a href="#">FLN10</a>            | \$31.00 | 5/8 in     |                     | 0.98 in <sup>2</sup>       |                                | 2940 lbs                                 | <a href="#">PDF</a> |
| <a href="#">FLN12</a>            | \$32.50 | 3/4 in     |                     | 1.27 in <sup>2</sup>       |                                | 3810 lbs                                 | <a href="#">PDF</a> |
| <a href="#">FLN16</a>            | \$55.00 | 1 in       |                     | 2.35 in <sup>2</sup>       |                                | 7050 lbs                                 | <a href="#">PDF</a> |
| <a href="#">FLN20</a>            | \$92.00 | 1 1/4 in   |                     | 3.43 in <sup>2</sup>       |                                | 10830 lbs                                | <a href="#">PDF</a> |
| <a href="#">FLC04</a>            | \$19.00 | 1/4 in     | closed              | 0.20 in <sup>2</sup>       | 0.0015 in                      | 600 lbs                                  | <a href="#">PDF</a> |
| <a href="#">FLC06</a>            | \$21.00 | 3/8 in     |                     | 0.34 in <sup>2</sup>       |                                | 1020 lbs                                 | <a href="#">PDF</a> |
| <a href="#">FLC08</a>            | \$22.00 | 1/2 in     |                     | 0.65 in <sup>2</sup>       |                                | 1950 lbs                                 | <a href="#">PDF</a> |
| <a href="#">FLC10</a>            | \$24.50 | 5/8 in     |                     | 0.98 in <sup>2</sup>       |                                | 2940 lbs                                 | <a href="#">PDF</a> |
| <a href="#">FLC12</a>            | \$25.00 | 3/4 in     |                     | 1.27 in <sup>2</sup>       |                                | 3810 lbs                                 | <a href="#">PDF</a> |
| <a href="#">FLC16</a>            | \$46.00 | 1 in       |                     | 2.35 in <sup>2</sup>       |                                | 7050 lbs                                 | <a href="#">PDF</a> |
| <a href="#">FLC20</a>            | \$77.00 | 1 1/4 in   |                     | 3.43 in <sup>2</sup>       |                                | 10830 lbs                                | <a href="#">PDF</a> |
| <a href="#">FLCN08</a>           | \$22.00 | 1/2 in     | open                | 0.65 in <sup>2</sup>       | 0.0015 in                      | 1950 lbs                                 | <a href="#">PDF</a> |
| <a href="#">FLCN10</a>           | \$24.50 | 5/8 in     |                     | 0.98 in <sup>2</sup>       |                                | 2940 lbs                                 | <a href="#">PDF</a> |
| <a href="#">FLCN12</a>           | \$25.00 | 3/4 in     |                     | 1.27 in <sup>2</sup>       |                                | 3810 lbs                                 | <a href="#">PDF</a> |
| <a href="#">FLCN16</a>           | \$46.00 | 1 in       |                     | 2.35 in <sup>2</sup>       |                                | 7050 lbs                                 | <a href="#">PDF</a> |
| <a href="#">FLCN20</a>           | \$77.00 | 1 1/4 in   |                     | 3.43 in <sup>2</sup>       |                                | 10830 lbs                                | <a href="#">PDF</a> |

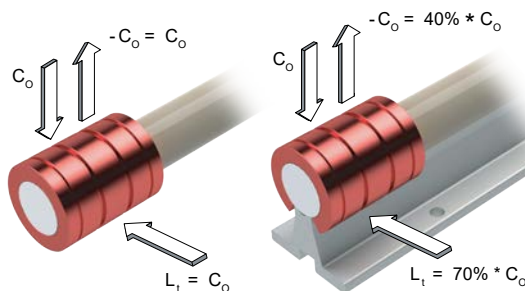

### Running Clearance

Simplicity bearings are available with two classes of running clearance:

#### Precision–“FL”:

- Performs like a preloaded ball bearing
- Tightest running clearance approximately 0.001" (0.025 mm)
- Used in applications that require high precision

*Not recommended for all parallel shaft applications. Any misalignment can cause binding on the shaft.*

*Recommend: Compensated–“FLC” (see below).*

#### Compensated–“FLC”:

- Performs like a standard ball bearing
- Additional clearance built into the I.D.–all other dimensions are the same as the precision bearings
- Ideally suited for parallel shaft applications

*Many parallel shaft applications will run “FL” precision on one rail and “FLC” compensation on the opposite rail to accommodate slight misalignments.*

### RUNNING CLEARANCE

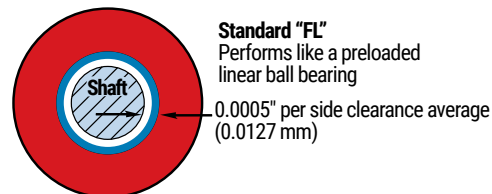

**Standard “FL”**  
Performs like a preloaded linear ball bearing

0.0005" per side clearance average (0.0127 mm)

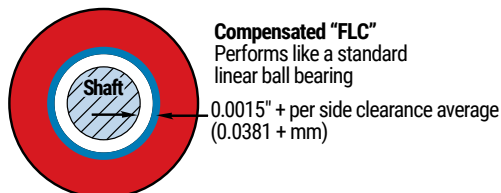

**Compensated “FLC”**  
Performs like a standard linear ball bearing

0.0015" + per side clearance average (0.0381 + mm)



Compensated plain bearings may feel too loose when installed. This is normal, and required, to prevent binding when used with dual shafts



# PBC Simplicity<sup>®</sup> Pillow Blocks

## PBC Linear Simplicity Pillow Block Features

- Simplicity Plain Bearing Pre-installed
- Pillow Block Housing Material: Aluminum alloy with clear anodize finish
- Centerline tolerance:  $\pm 0.001''$
- Internal self-aligning feature provides  $\pm 1/2^\circ$  bearing movement in all directions allowing for some shaft deflection and misalignment



Closed Bearing



Open Bearing

| Simplicity Pillow Block |          |            |                        |             |                            |                                |  |                     |                     |
|-------------------------|----------|------------|------------------------|-------------|----------------------------|--------------------------------|--|---------------------|---------------------|
| Part Number             | Price    | Nominal ID | Installed Bearing      | Form Factor | Effective Surface Area (A) | Running Clearance (Both Sides) | Max Static Load Rating (C <sub>0</sub> ) | Drawing Links       |                     |
| <a href="#">P04</a>     | \$53.00  | 1/4in      | <a href="#">FL04</a>   | closed type | 0.20 in <sup>2</sup>       | 0.0005 in                      | 600 lbs                                  | <a href="#">PDF</a> |                     |
| <a href="#">P06</a>     | \$55.00  | 3/8in      | <a href="#">FL06</a>   |             | 0.34 in <sup>2</sup>       |                                | 1020 lbs                                 | <a href="#">PDF</a> |                     |
| <a href="#">P08</a>     | \$61.00  | 1/2in      | <a href="#">FL08</a>   |             | 0.65 in <sup>2</sup>       |                                | 1950 lbs                                 | <a href="#">PDF</a> |                     |
| <a href="#">P10</a>     | \$68.00  | 5/8in      | <a href="#">FL10</a>   |             | 0.98 in <sup>2</sup>       |                                | 2940 lbs                                 | <a href="#">PDF</a> |                     |
| <a href="#">P12</a>     | \$71.00  | 3/4in      | <a href="#">FL12</a>   |             | 1.27 in <sup>2</sup>       |                                | 3810 lbs                                 | <a href="#">PDF</a> |                     |
| <a href="#">P16</a>     | \$103.00 | 1in        | <a href="#">FL16</a>   |             | 2.35 in <sup>2</sup>       |                                | 7050 lbs                                 | <a href="#">PDF</a> |                     |
| <a href="#">P20</a>     | \$155.00 | 1-1/4in    | <a href="#">FL20</a>   |             | 3.43 in <sup>2</sup>       |                                | 10830 lbs                                | <a href="#">PDF</a> |                     |
| <a href="#">PN08</a>    | \$71.00  | 1/2in      | <a href="#">FLN08</a>  | open type   | 0.65 in <sup>2</sup>       |                                | 1950 lbs                                 | <a href="#">PDF</a> |                     |
| <a href="#">PN10</a>    | \$82.00  | 5/8in      | <a href="#">FLN10</a>  |             | 0.98 in <sup>2</sup>       |                                | 2940 lbs                                 | <a href="#">PDF</a> |                     |
| <a href="#">PN12</a>    | \$88.00  | 3/4in      | <a href="#">FLN12</a>  |             | 1.27 in <sup>2</sup>       |                                | 3810 lbs                                 | <a href="#">PDF</a> |                     |
| <a href="#">PN16</a>    | \$125.00 | 1in        | <a href="#">FLN16</a>  |             | 2.35 in <sup>2</sup>       |                                | 7050 lbs                                 | <a href="#">PDF</a> |                     |
| <a href="#">PN20</a>    | \$188.00 | 1-1/4in    | <a href="#">FLN20</a>  |             | 3.43 in <sup>2</sup>       |                                | 10830 lbs                                | <a href="#">PDF</a> |                     |
| <a href="#">P04C</a>    | \$53.00  | 1/4in      | <a href="#">FLC04</a>  | closed type | 0.20 in <sup>2</sup>       |                                | 0.0015 in                                | 600 lbs             | <a href="#">PDF</a> |
| <a href="#">P06C</a>    | \$55.00  | 3/8in      | <a href="#">FLC06</a>  |             | 0.34 in <sup>2</sup>       |                                |  | 1020 lbs            | <a href="#">PDF</a> |
| <a href="#">P08C</a>    | \$61.00  | 1/2in      | <a href="#">FLC08</a>  |             | 0.65 in <sup>2</sup>       | 1950 lbs                       |  | <a href="#">PDF</a> |                     |
| <a href="#">P10C</a>    | \$68.00  | 5/8in      | <a href="#">FLC10</a>  |             | 0.98 in <sup>2</sup>       | 2940 lbs                       |  | <a href="#">PDF</a> |                     |
| <a href="#">P12C</a>    | \$72.00  | 3/4in      | <a href="#">FLC12</a>  |             | 1.27 in <sup>2</sup>       | 3810 lbs                       |  | <a href="#">PDF</a> |                     |
| <a href="#">P16C</a>    | \$103.00 | 1in        | <a href="#">FLC16</a>  |             | 2.35 in <sup>2</sup>       | 7050 lbs                       |  | <a href="#">PDF</a> |                     |
| <a href="#">P20C</a>    | \$155.00 | 1-1/4in    | <a href="#">FLC20</a>  |             | 3.43 in <sup>2</sup>       | 10830 lbs                      |  | <a href="#">PDF</a> |                     |
| <a href="#">PN08C</a>   | \$71.00  | 1/2in      | <a href="#">FLCN08</a> | open type   | 0.65 in <sup>2</sup>       | 1950 lbs                       |  | <a href="#">PDF</a> |                     |
| <a href="#">PN10C</a>   | \$82.00  | 5/8in      | <a href="#">FLCN10</a> |             | 0.98 in <sup>2</sup>       | 2940 lbs                       |  | <a href="#">PDF</a> |                     |
| <a href="#">PN12C</a>   | \$89.00  | 3/4in      | <a href="#">FLCN12</a> |             | 1.27 in <sup>2</sup>       | 3810 lbs                       |  | <a href="#">PDF</a> |                     |
| <a href="#">PN16C</a>   | \$125.00 | 1in        | <a href="#">FLCN16</a> |             | 2.35 in <sup>2</sup>       | 7050 lbs                       |  | <a href="#">PDF</a> |                     |
| <a href="#">PN20C</a>   | \$186.00 | 1-1/4in    | <a href="#">FLCN20</a> |             | 3.43 in <sup>2</sup>       | 10830 lbs                      |  | <a href="#">PDF</a> |                     |

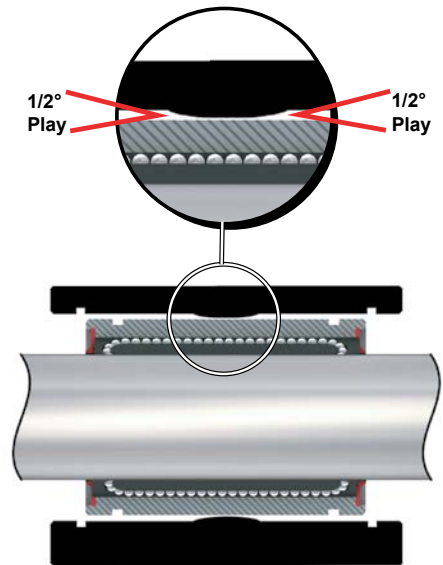

Internal Self-aligning Feature



FrelonGOLD<sup>®</sup> not recommended for use with deionized water and other harsh chemicals. See the chemical reaction chart page tLMN-84



# PBC Simplicity<sup>®</sup> Flange Mount Bearings

## PBC Linear Simplicity Flange Mount Features

- Simplicity Plain Bearing Pre-installed
- Flange Mount Housing Material: Aluminum alloy with clear anodize finish
- Internal self-aligning feature provides  $\pm 1/2^\circ$  bearing movement in all directions allowing for some shaft deflection and misalignment



| Simplicity Flange Mount Bearing |          |            |                        |                            |                                |  |                     |
|---------------------------------|----------|------------|------------------------|----------------------------|--------------------------------|--|---------------------|
| Part Number                     | Price    | Nominal ID | Installed Bearing      | Effective Surface Area (A) | Running Clearance (Both Sides) | Max Static Load Rating (C <sub>0</sub> ) | Drawing Links       |
| <a href="#">SFP06</a>           | \$105.00 | 3/8 in     | <a href="#">SFP06</a>  | 0.34 in <sup>2</sup>       | 0.0005 in                      | 1020 lbs                                 | <a href="#">PDF</a> |
| <a href="#">SFP08</a>           | \$83.00  | 1/2 in     | <a href="#">SFP08</a>  | 0.65 in <sup>2</sup>       |                                | 1950 lbs                                 | <a href="#">PDF</a> |
| <a href="#">SFP12</a>           | \$91.00  | 3/4 in     | <a href="#">SFP12</a>  | 1.27 in <sup>2</sup>       |                                | 3810 lbs                                 | <a href="#">PDF</a> |
| <a href="#">SFP16</a>           | \$130.00 | 1 in       | <a href="#">SFP16</a>  | 2.35 in <sup>2</sup>       |                                | 7050 lbs                                 | <a href="#">PDF</a> |
| <a href="#">SFP20</a>           | \$205.00 | 1 1/4 in   | <a href="#">SFP20</a>  | 3.43 in <sup>2</sup>       |                                | 10830 lbs                                | <a href="#">PDF</a> |
| <a href="#">SFP06C</a>          | \$105.00 | 3/8 in     | <a href="#">SFP06C</a> | 0.34 in <sup>2</sup>       | 0.0015 in                      | 1020 lbs                                 | <a href="#">PDF</a> |
| <a href="#">SFP08C</a>          | \$83.00  | 1/2 in     | <a href="#">SFP08C</a> | 0.65 in <sup>2</sup>       |                                | 1950 lbs                                 | <a href="#">PDF</a> |
| <a href="#">SFP12C</a>          | \$92.00  | 3/4 in     | <a href="#">SFP12C</a> | 1.27 in <sup>2</sup>       |                                | 3810 lbs                                 | <a href="#">PDF</a> |
| <a href="#">SFP16C</a>          | \$130.00 | 1 in       | <a href="#">SFP16C</a> | 2.35 in <sup>2</sup>       |                                | 7050 lbs                                 | <a href="#">PDF</a> |
| <a href="#">SFP20C</a>          | \$205.00 | 1 1/4 in   | <a href="#">SFP20C</a> | 3.43 in <sup>2</sup>       |                                | 10830 lbs                                | <a href="#">PDF</a> |

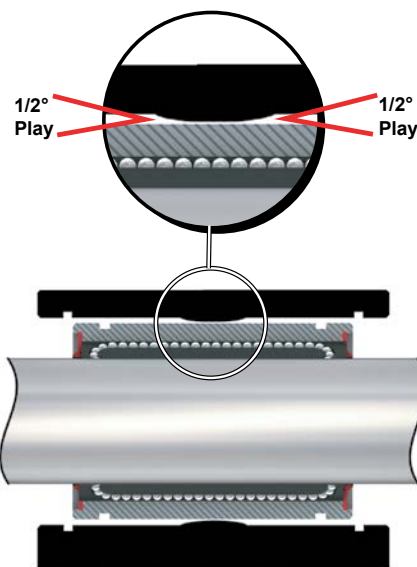

**Internal Self-aligning Feature**



FrelonGOLD<sup>®</sup> not recommended for use with deionized water and other harsh chemicals. See the chemical reaction chart page tLMN-84



# Chemical Reaction Chart for Simplicity® Bearings

The FrelonGOLD® material is a composite of PTFE and a bearing filler. The PTFE is chemically inert. The chemical resistance shown in the chart below is defined by the compatibility of the filler with the various chemicals.

Other data in the chart below applies to the bearing shell and pillow block materials. The table is provided as a reference only. The data given will be affected by factors such as temperature, PV, degree of contact, strength of solution, etc. In each specific application, it is always advisable to conduct specific testing to determine suitability of use. This table only addresses general corrosion, NOT galvanic, SCC, or other types of corrosion. Corrosion rates are at room temperature unless otherwise noted.

Standard and hard coat data only apply when the coating is intact. If the coating is worn through or damaged, an area of galvanic and pitting corrosion will be created. Then use the bare aluminum data.

Standard Simplicity products use aluminum alloy, which is known to have the best corrosion resistance of the high strength aluminum alloys. The sulfuric bath anodizing and nickel acetate sealing provide the best corrosion resistance available in anodized coatings. They can withstand a rigorous 14-day exposure in a 5% salt spray solution at 96°F per military specifications without significant damage. With the coating intact, it is considered to be inert in most fluids with a pH value between 5 and 8. Hard coat anodizing provides the same chemical resistance but is applied to a 0.002" thickness, providing a more durable surface that will stand up to greater abuse. However, if the coating is penetrated, the resistance is reduced.

Special stainless steel bearings use AISI 316 stainless, which has superior resistance over 303, 304, 420, 440, 17-4PH, and most other common stainless grades. 316 is generally considered to be the most corrosion resistant of conventional stainless steels.



This information was compiled for Pacific Bearing® Company by Materials Engineering, Inc. of Virgil, IL. This specification information is believed to be accurate and reliable, however, no liability is assumed. Information is for reference only. User must test specific applications.

| Performance        | Wear              |
|--------------------|-------------------|
| E = Excellent      | < 0.002" per year |
| G = Good           | < 0.020" per year |
| S = Satisfactory   | < 0.050" per year |
| U = Unsatisfactory | > 0.040" per year |

| Chemical                     | Frelon GOLD | Bare Aluminum | Standard & Hard Coat Anodized Aluminum | 316 Stainless Steel |
|------------------------------|-------------|---------------|--|---------------------|
| Acetic Acid, 20%             | U           | G             | G                                      | E                   |
| Acetone                      | G           | E             | E                                      | E                   |
| Ammonia, Anhydrous           | G           | E             | E                                      | E                   |
| Ammonium Hydroxide, 10%      | U           | U             | U                                      | E                   |
| Ammonium Chloride, 10%       | U           | U             | U                                      | G                   |
| Ammyl Acetate (122°F / 50°C) | G           | E             | E                                      | E                   |
| Barium Hydroxide             | U           | U             | U                                      | G                   |
| Beer                         | G           | E             | E                                      | E                   |
| Boric Acid Solutions         | G           | E             | E                                      | G                   |
| Butane                       | G           | G             | G                                      | G                   |
| Calcium Chloride, 20%        | G           | G             | G                                      | G                   |
| Calcium Hydroxide, 10%       | G           | G             | G                                      | G                   |
| Carbon Dioxide               | G           | E             | E                                      | G                   |
| Carbon Monoxide              | G           | E             | E                                      | E                   |
| Chlorine Gas, Dry            | G           | G             | G                                      | G                   |
| Chlorine Gas, Wet            | U           | U             | U                                      | U                   |
| Chromic Acid, 10%            | U           | G             | E                                      | E                   |
| Citric Acid, 5%              | G           | E             | E                                      | E                   |
| Ethyl Acetate                | G           | E             | E                                      | G                   |
| Ethyl Alcohol                | G           | E             | E                                      | G                   |
| Ethylene Glycol              | G           | E             | E                                      | G                   |
| Ferric Chloride, 50%         | U           | U             | U                                      | U                   |
| Formic Acid - Anhydrous      | U           | E             | E                                      | E                   |
| Gasoline, Unleaded           | G           | G             | G                                      | G                   |
| Hydrochloric Acid, 20%       | U           | U             | U                                      | U                   |
| Hydrochloric Acid, 35%       | U           | U             | U                                      | U                   |
| Hydrocyanic Acid, 10%        | U           | G             | G                                      | G                   |
| Hydrofluoric Acid - Dilute   | U           | U             | U                                      | U                   |
| Hydrofluoric Acid, 48%       | U           | U             | U                                      | U                   |
| Hydrogen                     | G           | E             | E                                      | E                   |
| Hydrogen Peroxide - Dilute   | U           | E             | E                                      | G                   |

| Chemical                 | Frelon GOLD | Bare Aluminum | Standard & Hard Coat Anodized Aluminum | 316 Stainless Steel |
|--------------------------|-------------|---------------|--|---------------------|
| Hydrogen Sulfide, Dry    | U           | G             | E                                      | E                   |
| JP-4                     | G           | G             | G                                      | G                   |
| Kerosene                 | G           | G             | G                                      | G                   |
| Lactic Acid, 10%         | G           | G             | G                                      | E                   |
| Magnesium Chloride, 50%  | G           | U             | U                                      | G                   |
| Mercury                  | U           | U             | U                                      | E                   |
| Methyl Alcohol           | G           | G             | G                                      | G                   |
| Methyl Ethyl Ketone      | G           | G             | G                                      | G                   |
| Methylene Chloride       | G           | E             | E                                      | G                   |
| Mineral Oil              | G           | G             | G                                      | G                   |
| Naptha                   | G           | G             | G                                      | G                   |
| Nitric Acid, 70%         | U           | U             | U                                      | E                   |
| Phosphoric Acid, 10%     | U           | U             | U                                      | E                   |
| Sodium Chloride          | G           | U             | U                                      | E                   |
| Sodium Hydroxide, 20%    | G           | U             | U                                      | G                   |
| Sodium Hypochlorite, 20% | U           | G             | G                                      | U                   |
| Sodium Peroxide, 10%     | U           | G             | G                                      | G                   |
| Steam (see water)        | -           | -             | -                                      | -                   |
| Sulfur Dioxide, Wet      | U           | U             | U                                      | G                   |
| Sulfur Dioxide, Dry      | G           | G             | G                                      | G                   |
| Sulfur Trioxide          | U           | G             | G                                      | G                   |
| Sulfuric Acid, 50%       | U           | U             | U                                      | U                   |
| Sulfurous Acid           | U           | G             | G                                      | E                   |
| Toluene (122°F / 50°C)   | G           | E             | E                                      | E                   |
| Turpentine               | G           | G             | E                                      | E                   |
| Water, Demineralized     | U           | G             | E                                      | E                   |
| Water, Distilled         | G           | U             | S                                      | G                   |
| Sea Water                | G           | G             | E                                      | G                   |
| Water, Sewage            | G           | U             | S                                      | G                   |
| Xylene                   | G           | G             | G                                      | G                   |
| Zinc Chloride Solutions  | U           | U             | U                                      | G                   |



# PBC Linear Ball Bearings

## High Precision and Rigidity

The ball bearing is produced from a solid steel outer cylinder and incorporates an industrial strength polymer retainer.

## Ease of Assembly

The standard type of linear ball bearing can be loaded from any direction. Precision control is possible using only the shaft supporter, and the mounting surface can be machined easily.

## Ease of Replacement

Linear ball bearings of each type are completely interchangeable because of their standardized dimensions and strict precision control. Replacement because of wear or damage is therefore easy and accurate.

## Materials

Ball bearings consist of an outer cylinder, ball retainer, balls, double seals, and two end rings. The ball retainer which holds the balls in the recirculating tracks is held inside the outer cylinder by end rings.

- Parts are assembled to optimize their required functions.
- The outer shell is heat treated to ensure long life.
- The ball retainer is molded from a durable polymer to ensure smooth and quiet motion.
- Double seals are standard.

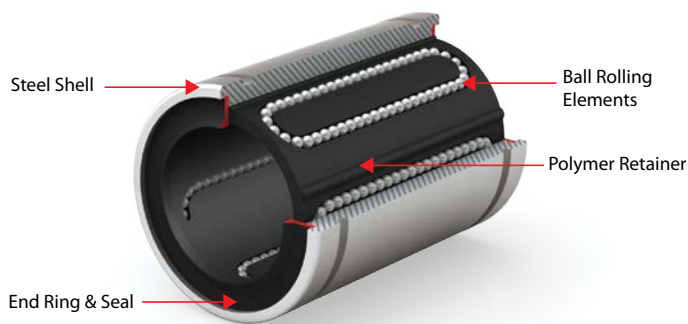

Ball Bearing  
Better performance for moment loading  
Balls provide precise, low-friction performance but are susceptible to contamination

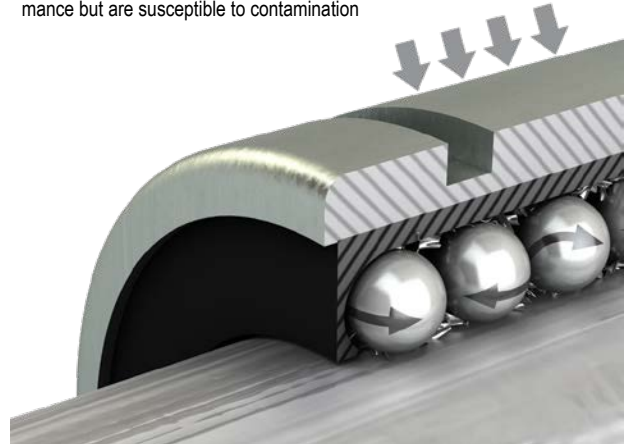

## Pillow Blocks and Flange Mounts

- Made of aluminum alloy
- Clear anodized finish (Standard)
- Pillow blocks are interchangeable with industry standard ball bearing pillow blocks
- Critical centerline dimensions hold accuracy within  $\pm 0.001$ ".

## Self-Alignment

Standard pillow blocks have built-in self-alignment in all directions:

- Standard pillow blocks have  $1/2^\circ$  misalignment from centerline
- This feature is built into the housing with a spherical radius at the midpoint of the block
- This self-aligning capability will allow for some shaft deflection and misalignment

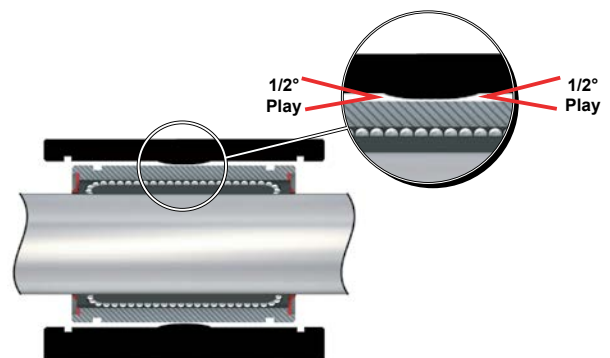





# PBC Linear Ball Bearings

## PBC Linear Ball Bearing Features

- For Linear, oscillating, rotary motion, or combination of all 3
- End Seals included
- Bearing Shell Material: GCr15 Steel, heat treated
- Bearing Material: GCr15 Steel
- Bearing Retainer Material: Polyoxymethylene polymer
- Lubrication required

## Performance Ratings (for Linear Motion)

- Coefficient of friction: 0.05
- Maximum Speed ( $V_{max}$ ): 590 ft/min
- IP04G-xx thru IP16G-xx ID tolerance: 0/-0.0005"
- IP20G-xx ID tolerance: 0/-0.0006"



Closed Bearing



Open Bearing

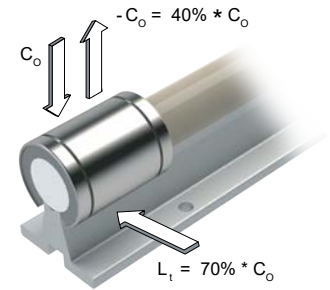
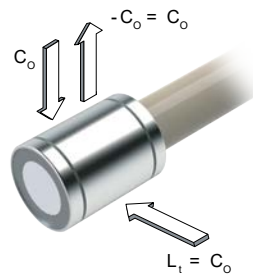

| PBC Linear Ball Bearing  |         |            |                     |           |                |                              |                         |                     |
|--------------------------|---------|------------|---------------------|-----------|----------------|------------------------------|-------------------------|---------------------|
| Part Number              | Price   | Nominal ID | Bearing Form Factor | OD        | Overall Length | Static Load Rating ( $C_o$ ) | Dynamic Load Rating (C) | Drawing Links       |
| <a href="#">IP04G</a>    | \$15.50 | 1/4 in     | closed              | 1/2 in    | 3/4in          | 59 lbs                       | 46 lbs                  | <a href="#">PDF</a> |
| <a href="#">IP06G</a>    | \$16.50 | 3/8 in     |                     | 5/8 in    | 7/8in          | 70 lbs                       | 50 lbs                  | <a href="#">PDF</a> |
| <a href="#">IP08G</a>    | \$17.00 | 1/2 in     |                     | 7/8 in    | 1-1/4in        | 178 lbs                      | 114 lbs                 | <a href="#">PDF</a> |
| <a href="#">IP10G</a>    | \$19.00 | 5/8 in     |                     | 1 1/8 in  | 1-1/2in        | 265 lbs                      | 174 lbs                 | <a href="#">PDF</a> |
| <a href="#">IP12G</a>    | \$21.00 | 3/4 in     |                     | 1 1/4 in  | 1-5/8in        | 307 lbs                      | 193 lbs                 | <a href="#">PDF</a> |
| <a href="#">IP16G</a>    | \$38.00 | 1 in       |                     | 1 9/16 in | 2-1/4in        | 352 lbs                      | 220 lbs                 | <a href="#">PDF</a> |
| <a href="#">IP20G</a>    | \$64.00 | 1 1/4 in   |                     | 2 in      | 2-5/8in        | 615 lbs                      | 352 lbs                 | <a href="#">PDF</a> |
| <a href="#">IP08G-OP</a> | \$24.50 | 1/2 in     | open                | 7/8 in    | 1-1/4in        | 178 lbs                      | 114 lbs                 | <a href="#">PDF</a> |
| <a href="#">IP10G-OP</a> | \$25.50 | 5/8 in     |                     | 1 1/8 in  | 1-1/2in        | 265 lbs                      | 174 lbs                 | <a href="#">PDF</a> |
| <a href="#">IP12G-OP</a> | \$27.50 | 3/4 in     |                     | 1 1/4 in  | 1-5/8in        | 307 lbs                      | 193 lbs                 | <a href="#">PDF</a> |
| <a href="#">IP16G-OP</a> | \$51.00 | 1 in       |                     | 1 9/16 in | 2-1/4in        | 352 lbs                      | 220 lbs                 | <a href="#">PDF</a> |
| <a href="#">IP20G-OP</a> | \$86.00 | 1 1/4 in   |                     | 2 in      | 2-5/8in        | 615 lbs                      | 352 lbs                 | <a href="#">PDF</a> |



# PBC Linear Ball-Bearing Pillow Blocks

## PBC Linear Ball Bearing Pillow Block Features

- PBC Linear Ball Bearing Pre-installed
- Pillow Block Housing Material: Aluminum alloy with clear anodize finish
- Centerline tolerance:  $\pm 0.001''$
- Internal self-aligning feature provides  $\pm 1/2^\circ$  bearing movement in all directions allowing for some shaft deflection and misalignment
- IPP(x)04G thru IPP(x)16G ID tolerance: 0/-0.0005"
- IPP(x)20G ID tolerance: 0/-0.0006"



Closed Bearing



Open Bearing

| PBC Ball Bearing Pillow Block |          |            |                          |             |                              |                         |                     |
|-------------------------------|----------|------------|--------------------------|-------------|------------------------------|-------------------------|---------------------|
| Part Number                   | Price    | Nominal ID | Installed Bearing        | Form Factor | Static Load Rating ( $C_0$ ) | Dynamic Load Rating (C) | Drawing Links       |
| <a href="#">IPP04G</a>        | \$27.48  | 1/4in      | <a href="#">IP04G</a>    | closed type | 59 lbs                       | 48 lbs                  | <a href="#">PDF</a> |
| <a href="#">IPP06G</a>        | \$51.00  | 3/8in      | <a href="#">IP06G</a>    |             | 70 lbs                       | 50 lbs                  | <a href="#">PDF</a> |
| <a href="#">IPP08G</a>        | \$56.00  | 1/2in      | <a href="#">IP08G</a>    |             | 178 lbs                      | 114 lbs                 | <a href="#">PDF</a> |
| <a href="#">IPP10G</a>        | \$62.00  | 5/8in      | <a href="#">IP10G</a>    |             | 265 lbs                      | 174 lbs                 | <a href="#">PDF</a> |
| <a href="#">IPP12G</a>        | \$66.00  | 3/4in      | <a href="#">IP12G</a>    |             | 307 lbs                      | 193 lbs                 | <a href="#">PDF</a> |
| <a href="#">IPP16G</a>        | \$93.00  | 1in        | <a href="#">IP16G</a>    |             | 352 lbs                      | 220 lbs                 | <a href="#">PDF</a> |
| <a href="#">IPP20G</a>        | \$140.00 | 1-1/4in    | <a href="#">IP20G</a>    |             | 615 lbs                      | 352 lbs                 | <a href="#">PDF</a> |
| <a href="#">IPPN08G</a>       | \$68.00  | 1/2in      | <a href="#">IP08G-OP</a> | open type   | 178 lbs                      | 114 lbs                 | <a href="#">PDF</a> |
| <a href="#">IPPN10G</a>       | \$78.00  | 5/8in      | <a href="#">IP10G-OP</a> |             | 265 lbs                      | 174 lbs                 | <a href="#">PDF</a> |
| <a href="#">IPPN12G</a>       | \$85.00  | 3/4in      | <a href="#">IP12G-OP</a> |             | 307 lbs                      | 193 lbs                 | <a href="#">PDF</a> |
| <a href="#">IPPN16G</a>       | \$122.00 | 1in        | <a href="#">IP16G-OP</a> |             | 352 lbs                      | 220 lbs                 | <a href="#">PDF</a> |
| <a href="#">IPPN20G</a>       | \$183.00 | 1-1/4in    | <a href="#">IP20G-OP</a> |             | 615 lbs                      | 352 lbs                 | <a href="#">PDF</a> |

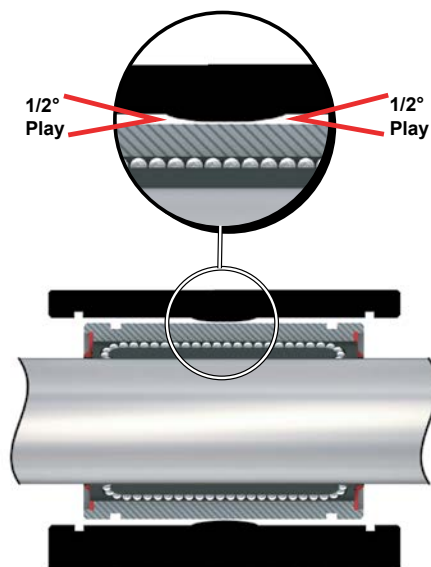

Internal Self-aligning Feature



# Roller Pillow Blocks

## Features

The Roller Pillow Block system carries heavy loads and easily maneuvers over joined or misaligned shafts over long travels. The system is corrosion resistant and provides high speeds and rigidity in the toughest applications. Large cam followers, equipped with side seals, deliver industrial strength performance and excel in dirty environments.

- Superior for joined rail applications
- Best suited for horizontal applications with normal downward loading
- Available in 3 Cam Follower Configurations
- Available for various shaft sizes from 1/2" thru 1 1/4"
- Dynamic Load Rating up to 2,800 lbf (12,455 N)
- Adjustable clearance
- Corrosion resistant
- Interchangeable with industry standard pillow blocks



Large cam follower design with side seals delivers superior contaminant resistance



Roller pillow block's large cam follower navigates joined shafts and rail assemblies with ease

**Twin  
(TWN-xx)**

**Single  
(SPB-xx)**

**Double  
(DPB-xx)**

## Loading and Design

Roller Pillow Blocks are best suited for Normal Downward Loading and used together as shown here with 2 rails and 4 roller pillow blocks. Individually they are not designed for large moment loads, so such loading will lead to premature failure

**Normal Loading**

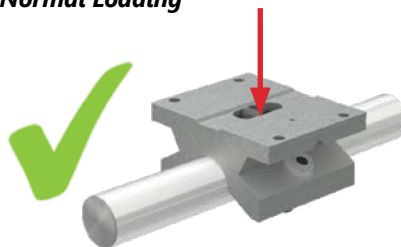

**Inverted Load**

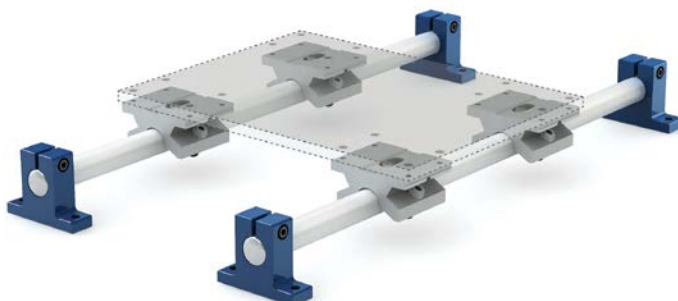

# Roller Pillow Blocks

## Features

- Pillow Block Housing Material: Aluminum
- Bearing Type: Sealed Cam Follower
- Bearing Material: Carbon Steel
- Linear travel maximum speed: 7.6m/s (25ft/s)
- Single Roller Pillow Block (SPB-xx)
  - Self aligning +/-0.5°
  - Can be used on curved rails
- Double Roller Pillow Block (DPB-xx)
  - Twice the dynamic load rating of Single Pillow Block
- Twin Roller Pillow Block (TWN-xx)
  - Same load rating as Double Roller Pillow Block
  - Can be used when using only one block per shaft
- Compatible with linear precision ground shafts such as the PBC Simplicity 60 Plus series (sold by AutomationDirect)



**SPB-08-OPN**



**DPB-08-OPN**



**TWN-08-OPN**

## Roller Pillow Block Specifications

| Part Number                       | Price    | For Shaft Diameter | Carriage Length (C) | Dynamic (C) (N) | Drawing Links              |
|-----------------------------------|----------|--------------------|---------------------|-----------------|----------------------------|
| <b>Single Roller Pillow Block</b> |          |                    |                     |                 |                            |
| <a href="#"><u>SPB-08-OPN</u></a> | \$180.00 | 1/2in              | 1.5 in              | 1779            | <a href="#"><u>PDF</u></a> |
| <a href="#"><u>SPB-10-OPN</u></a> | \$150.00 | 5/8in              | 1.75 in             | 2224            | <a href="#"><u>PDF</u></a> |
| <a href="#"><u>SPB-12-OPN</u></a> | \$140.00 | 3/4in              | 1.87 in             | 2669            | <a href="#"><u>PDF</u></a> |
| <a href="#"><u>SPB-16-OPN</u></a> | \$160.00 | 1in                | 2.62 in             | 4248            | <a href="#"><u>PDF</u></a> |
| <a href="#"><u>SPB-20-OPN</u></a> | \$192.00 | 1-1/4in            | 3.37 in             | 6228            | <a href="#"><u>PDF</u></a> |
| <b>Double Roller Pillow Block</b> |          |                    |                     |                 |                            |
| <a href="#"><u>DPB-08-OPN</u></a> | \$283.00 | 1/2in              | 2 in                | 3559            | <a href="#"><u>PDF</u></a> |
| <a href="#"><u>DPB-10-OPN</u></a> | \$241.00 | 5/8in              | 2.5 in              | 4448            | <a href="#"><u>PDF</u></a> |
| <a href="#"><u>DPB-12-OPN</u></a> | \$251.00 | 3/4in              | 2.62 in             | 5338            | <a href="#"><u>PDF</u></a> |
| <a href="#"><u>DPB-16-OPN</u></a> | \$273.00 | 1in                | 2.62 in             | 8496            | <a href="#"><u>PDF</u></a> |
| <a href="#"><u>DPB-20-OPN</u></a> | \$376.00 | 1-1/4in            | 3.37 in             | 12455           | <a href="#"><u>PDF</u></a> |
| <b>Twin Roller Pillow Block</b>   |          |                    |                     |                 |                            |
| <a href="#"><u>TWN-08-OPN</u></a> | \$302.00 | 1/2in              | 3.5 in              | 3559            | <a href="#"><u>PDF</u></a> |
| <a href="#"><u>TWN-10-OPN</u></a> | \$253.00 | 5/8in              | 4 in                | 4448            | <a href="#"><u>PDF</u></a> |
| <a href="#"><u>TWN-12-OPN</u></a> | \$256.00 | 3/4in              | 4.5 in              | 5338            | <a href="#"><u>PDF</u></a> |
| <a href="#"><u>TWN-16-OPN</u></a> | \$290.00 | 1in                | 6 in                | 8496            | <a href="#"><u>PDF</u></a> |
| <a href="#"><u>TWN-20-OPN</u></a> | \$392.00 | 1-1/4in            | 7.5 in              | 12455           | <a href="#"><u>PDF</u></a> |

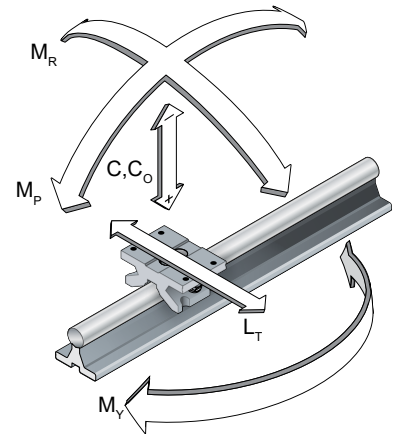

Note: Pillow blocks are designed for only downward, normal loads (C). Moment loads and Lateral Loads (Lt) are not recommended and not rated.



# Roller Pillow Blocks

## Adjustments

Roller Pillow Blocks are factory set for use with Simplicity® 60 Plus® shafting (sold by AutomationDirect). Adjustments can be made to the eccentric cam follower to either increase or decrease the shaft clearance.

Located on the same side of the Roller Pillow Block as the set screw, the eccentric cam follower is adjusted by using a stubby allen wrench while allowing a 0.002" feeler gauge to freely move between the shaft and the eccentric roller. The fixed side must remain in contact with the shaft. If care is taken not to overload the roller, then a slight pre-load is possible. Rollers should never be tightened to the point where they cannot move freely.

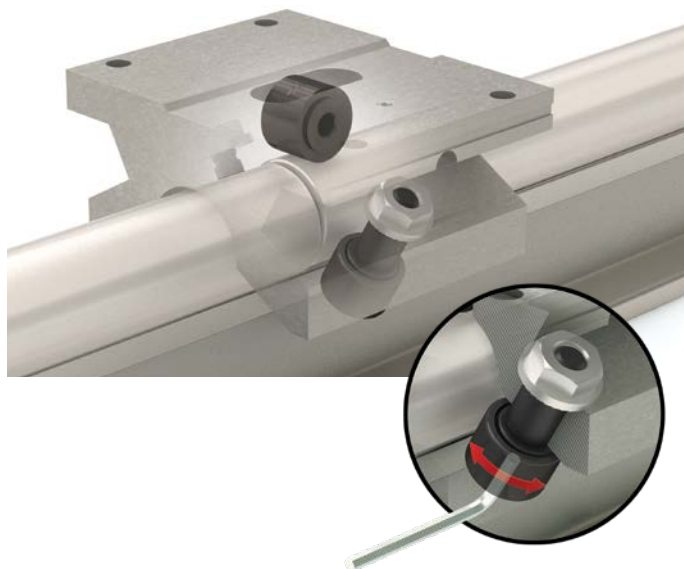

## Turning a Curve

A single Roller Pillow Block has the ability to turn a curve or run on a non-linear system. The following table lists the minimum track radius that the single Roller Pillow Block can tolerate without additional alteration.

| Pillow Block Size | Minimum Track Radius |
|-------------------|----------------------|
| 8                 | 6"                   |
| 10                | 12"                  |
| 12                | 14"                  |
| 16                | 18"                  |
| 20                | 36"                  |

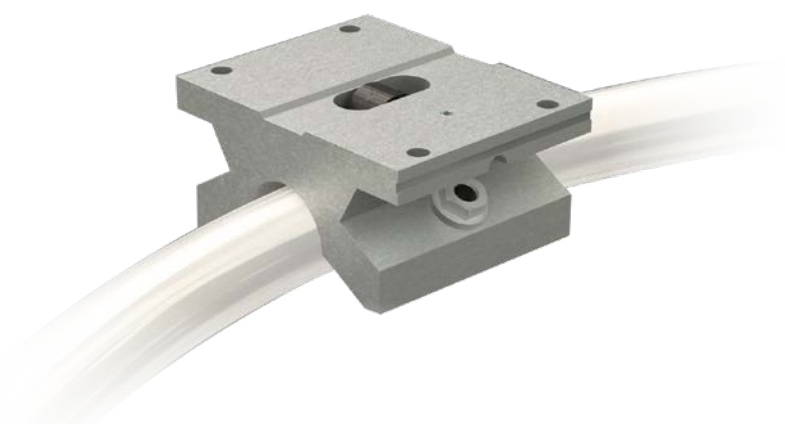

## Lubrication, Rails & Bearings

The rollers are internally lubricated for life, but the rails must always have a layer of grease. As a guideline, reapply fresh grease every 50,000 cycles.

