

Analog Input Modules

P2-08ADS-1

\$449.00

Current Analog Input

The P2-08ADS-1 Isolated Current Analog Input Module provides eight channels for receiving 0-20 mA signals for use with the Productivity2000 system.

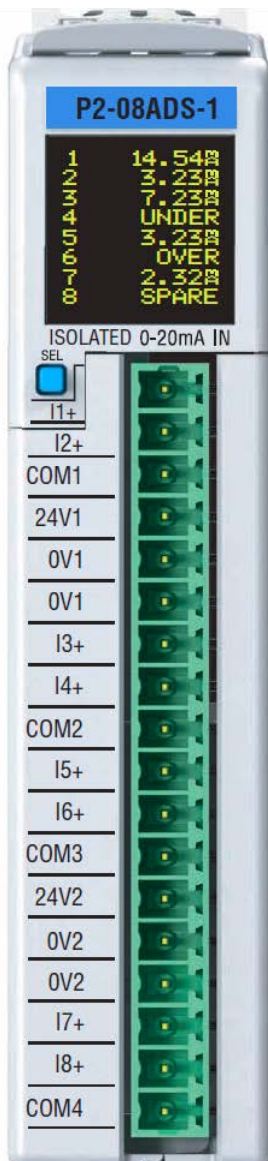

Terminal block sold separately.

Input Specifications	
Input Channels	8 with pairs of 4 isolated channels
Module Signal Input Range	0–20 mA
Signal Resolution	16-bit
Resolution Value of LSB (least significant bit)	0–20 mA = 0.305 μ A per count (1 LSB = 1 count)
Data Range	0 to 65535 counts
Input Type	Sinking, single-ended (1 common)
Maximum Continuous Overload	\pm 31 mA
Input Impedance	240 Ω \pm 0.1% 1/10W
Filter Characteristics	Low Pass, -3 dB @ 22.1 Hz
Sample Duration Time	60 ms per channel (does not include ladder scan time)
All Channel Update Rate	600 ms
Open Circuit Detection Time	Zero reading within 1s
Conversion Method	Sigma-Delta
Accuracy vs. Temperature	\pm 25 PPM / $^{\circ}$ C maximum
Maximum Inaccuracy	0.1% of range (including temperature drift)
Linearity Error (end to end)	\pm 0.015% of range Monotonic with no missing codes
Input Stability and Repeatability	\pm 0.015% of range (after 10 min. warm-up)
Maximum Full Scale Calibration Error	\pm 0.015% of range maximum
Offset Calibration Error	\pm 0.015% of range maximum
Max Crosstalk as DC, 50 Hz and 60 Hz	-76 dB, \pm 10 LSB
External DC Power Required	24 VDC (-20% / +25%) 86 mA
Recommended Fuse (external)	Internal resettable fuse; fuse protects input up to 31 mA fuse opens for input >100 mA*

* Module could return data for input between 31 to 100 mA.

Removable Terminal Block Specifications		
Part Number	P2-RTB	P2-RTB-1
Number of positions	18 screw terminals	18 spring clamp terminals
Wire Range	30–16 AWG [0.051–1.31 mm ²] Solid/stranded conductor 3/64in [1.2mm] insulation max. 1/4in [6–7mm] strip length	28–16 AWG [0.081–1.31 mm ²] Solid/stranded conductor 3/64in [1.2mm] insulation max. 19/64in [7–8mm] strip length
Conductors	USE COPPER CONDUCTORS, 75 $^{\circ}$ C or equivalent.	
Screw Driver Width	0.1in [2.5mm] maximum*	N/A
Screw Size	M2	N/A
Screw Torque	2.5 lb·in [0.28 N·m]	N/A

* Recommended screw driver: P/N TW-SD-MSL-1.

Diagnostic/Status	
Under Range Error	1 bit per channel
Over Range Error	1 bit per channel
Module Failed	1 bit per module
Missing 24V	1 bit per module

We recommend using prewired ZIPLink cables and connection modules. See Wire & Cable Termination.

If you wish to hand-wire your module, a removable terminal block is sold separately. Order part number P2-RTB or P2-RTB-1.



Analog Input Modules

P2-08ADS-1 (cont'd)

General Specifications	
Operating Temperature	0 to 60 °C [32 to 140 °F]
Storage Temperature	-20 to +70 °C [-4 to +158 °F]
Humidity	5 to 95% (non-condensing)
Altitude	2000m max.
Pollution Degree	2
Environmental Air	No corrosive gases permitted
Vibration	IEC60068-2-6 (Test Fc)
Shock	IEC60068-2-27 (Test Ea)
Field to Logic Side Isolation	1750 VAC applied for 5s or 420 VDC applied for 1 minute
Input to Power Supply Isolation	1750 VAC applied for 5s or 420 VDC applied for 1 minute
Input to Input Isolation	1750 VAC applied for 5s or 420 VDC applied for 1 minute
Insulation Resistance	>10 MΩ @ 500 VDC
Heat Dissipation	1870 mW
Overvoltage Category	II
Enclosure Type	Open equipment
Module Keying to Backplane	Electronic
Module Location	Any I/O slot in a Productivity2000 system
Field Wiring	Use ZIPLink wiring system or removable terminal block (not included). See Wire & Cable Termination.
Connector Type (Sold separately)	18-position removable terminal block
Weight	3.8 oz [107g]
Agency Approvals**	UL 61010-1 and UL 61010-2-201 File E139594, Canada & USA CE (EN 61131-2 EMC, EN 61010-1 and EN 61010-2-201 Safety)*

*Meets EMC and Safety requirements. See the Declaration of Conformity for details.

**To obtain the most current agency approval information, see the Agency Approval Checklist section on the specific component part number web page.

Wiring Diagrams

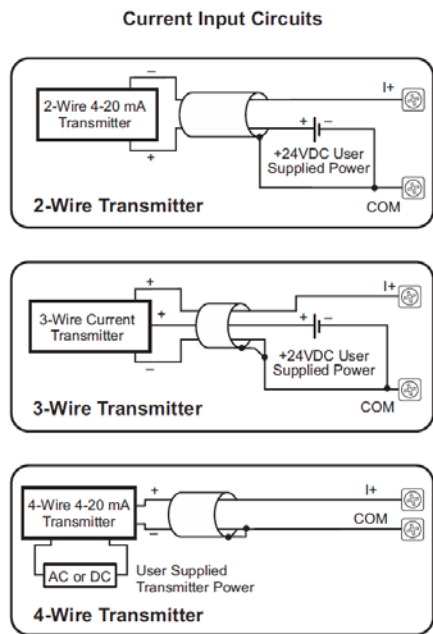

Note: Do not connect both ends of shield.

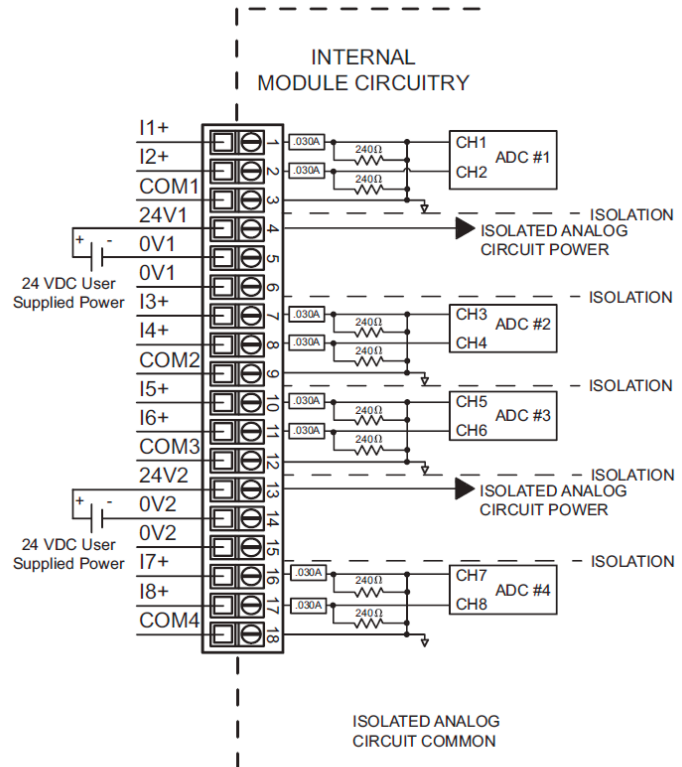

*Note: Sourcing power to both 24V1 and 24V2 is required.

Wiring I/O Modules

Wiring Methods

There are two available methods for wiring most I/O modules: The ZIPLink wiring system (See page following), or hand wiring to the optional Removable Terminal Blocks.



Removable Terminal Blocks

For most I/O modules you can purchase a removable terminal block (p/n shown below).

Note: Thermocouple and RTD modules are not compatible with the ZIPLink system and are shipped with the optional terminal blocks included.

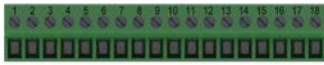

Removable Terminal Block: p/n [P2-RTB](#)

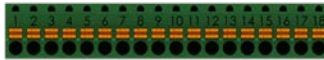

Removable Terminal Block: p/n [P2-RTB-1](#)

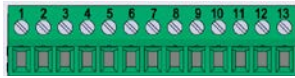

Removable Terminal Block: p/n [P2-RTB13](#)

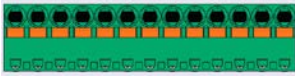

Removable Terminal Block: p/n [P2-RTB13-1](#)

Removable Terminal Block Specifications		
Part Number	P2-RTB	P2-RTB-1
Price	\$10.00	\$10.00
Number of positions	18 screw terminals	18 push release terminals
Wire Range	30–16 AWG [0.051–1.31 mm ²] Solid/stranded conductor 3/64in [1.2mm] insulation max. 1/4in [6–7mm] strip length	28–16 AWG [0.081–1.31 mm ²] Solid/stranded conductor 3/64in [1.2mm] insulation max. 19/64in [7–8mm] strip length
Conductors	USE COPPER CONDUCTORS, 75 °C or equivalent.	
Screw Driver Width	0.1 in. [2.5mm] maximum	N/A
Screw Size	M2	N/A
Screw Torque	2.5 lb·in [0.28 N·m]	N/A

* Recommended screw driver: P/N [TW-SD-MSL-1](#).

Removable Terminal Block Specifications		
Part Number	P2-RTB13	P2-RTB13-1
Price	\$11.50	\$11.50
Number of positions	13 screw terminals	13 push release terminals
Wire Range	24–12 AWG [0.25–4 mm ²] Solid/stranded conductor 3/64in [1.2mm] insulation max. 3/8in [9–10mm] strip length	
Conductors	USE COPPER CONDUCTORS, 75 °C or equivalent.	
Screw Driver Width	0.13in [3.5mm] maximum	N/A
Screw Size	M2.5	N/A
Screw Torque	4.4 lb·in [0.5 N·m]	N/A

* Recommended screw driver: P/N [TW-SD-MSL-1](#).

Terminal Block Removal

Removable Terminal Blocks fit firmly into the I/O module terminal recess. To remove, firmly grasp the removable terminal block and wiggle side to side while pulling away from the module.





Wiring Solutions

Wiring Solutions using the ZIPLink wiring system

ZIPLinks eliminate the normally tedious process of wiring between devices by utilizing prewired cables and DIN rail mount connector modules. It's as simple as plugging in a cable connector at either end and terminating wires at only one end. Prewired cables keep installation clean and efficient, using half the space at a fraction of the cost of standard terminal blocks. There are several wiring solutions available when using the ZIPLink System ranging from CPU

I/O-to-ZIPLink Connector Modules that are ready for field termination, options for connecting to third party devices, GS Series, DuraPulse and SureServo Drives, and specialty relay, transorb and communications modules. Pre-printed I/O-specific adhesive label strips for quick marking of ZIPLink modules are provided with ZIPLink cables. See the following solutions to help determine the best ZIPLink system for your application.

Solution 1: DirectLOGIC, CLICK, Productivity® 1000, Productivity® 2000 and Productivity3000® I/O Modules to ZIPLink Connector Modules

When looking for quick and easy I/O-to-field termination, a ZIPLink connector module used in conjunction with a prewired ZIPLink cable, consisting of an I/O terminal block at one end and a multi-pin connector at the other end, is the best solution.



Use the CPU I/O Modules to ZIPLink Connector Modules selector tables located in the ZIPLink Wiring Solutions section to:

1. Locate your I/O module/CPU,
2. Select a ZIPLink Module, and
3. Select a corresponding ZIPLink Cable.

Solution 2: DirectLOGIC, CLICK, Productivity1000, Productivity2000 and Productivity3000 I/O Modules to 3rd Party Devices

When wanting to connect I/O to another device within close proximity of the I/O modules, no extra terminal blocks are necessary when using the ZIPLink Pigtail Cables. ZIPLink Pigtail Cables are prewired to an I/O terminal block with color-coded pigtail with soldered-tip wires on the other end.



Use the I/O Modules to 3rd Party Devices selector tables located in the ZIPLink Wiring Solutions section to:

1. Locate your CPU I/O module, and
2. Select a ZIPLink Pigtail Cable that is compatible with your 3rd party device.

Solution 3: GS Series and DuraPulse Drives Communication Cables

Need to communicate via Modbus RTU to a drive or a network of drives?

ZIPLink cables are available in a wide range of configurations for connecting to CPUs, SureServo, SureStep, Stellar Soft Starter and AC drives. Add a ZIPLink communications module to quickly and easily set up a multi-device network.

Use the Drives Communication selector tables located in the ZIPLink Wiring Solutions section to:

1. Locate your Drive and type of communications, and
2. Select a ZIPLink cable and other associated hardware.





Wiring Solutions

Solution 4: Serial Communications Cables

ZIPLink offers communications cables for use with DirectLOGIC, CLICK, Productivity1000, Productivity2000 and Productivity3000 CPUs, that can also be used with other communications devices. Connections include a 6-pin RJ12 or 9-pin, 15-pin and 25-pin D-Sub connectors which can be used in conjunction with the RJ12 or D-Sub Feedthrough modules.

Using the Serial Communications Cables selector table located in the ZIPLink Wiring Solutions section,

1. Locate your connector type
2. Select a cable.



Solution 5: Specialty ZIPLink Modules

For additional application solutions, ZIPLink Specialty Modules are available in a variety of configurations including stand-alone relays, 24 VDC and 120 VAC transorb modules, D-Sub, RJ12 and RJ45 feedthrough modules, communication port adapter and distribution modules, and SureServo 50-pin I/O interface connection.

Using the ZIPLink Specialty Modules selector table located in the ZIPLink Wiring Solutions section:

1. Locate the type of application.
2. Select a ZIPLink module.



Solution 6: ZIPLink Connector Modules to 3rd Party Devices

If you need a way to connect your device to terminal blocks without all that wiring time, then our pigtail cables with color-coded soldered-tip wires are a good solution. Used in conjunction with any compatible ZIPLink Connector Modules, a pigtail cable keeps wiring clean and easy and reduces troubleshooting time.

Use the Universal Connector Modules and Pigtail Cables table located in the ZIPLink Wiring Solutions section to:

1. Select module type,
2. Select the number of pins
3. Select cable.





I/O Modules to ZIPLink Connector Modules - Productivity2000

Analog Input Modules

Productivity2000 Analog Input Module ZIPLink Selector				
I/O Analog Module	ZIPLink Parameters			
	# of Terms	Component	Part No.	Cable Part No.
P2-04AD	18	Feedthrough	ZL-RTB20 (-1)	ZL-P2-CBL18 *
P2-04AD-1				
P2-04AD-2				
P2-08AD-1				
P2-08AD-2				
P2-08ADL-1				
P2-08ADL-2				
P2-08ADS-1				
P2-08ADS-2				
P2-16AD-1				
P2-16AD-2				
P2-16ADL-1	24			ZL-P2-CBL24 *
P2-16ADL-2				
P2-06RTD	Matched Only	See Note 1		
P2-08THM	T/C Wire Only	See Note 1		
P2-08THMS	T/C Wire Only	See Note 1		
P2-08NTC	Copper Conductors	See Note 1		

Analog Output Modules

Productivity2000 Analog Output Module ZIPLink Selector				
I/O Analog Module	ZIPLink Parameters			
	# of Terms	Component	Part No.	Cable Part No.
P2-04DA	18	Feedthrough	ZL-RTB20 (-1)	ZL-P2-CBL18 *
P2-04DA-1				
P2-04DA-2				
P2-04DAL-1				
P2-04DAL-2				
P2-08DA-1				
P2-08DA-2				
P2-08DAL-1				
P2-08DAL-2				
P2-16DA-1				
P2-16DA-2				
P2-16DAL-1	24			ZL-P2-CBL24 *
P2-16DAL-2				
P2-8AD4DA-1	18			ZL-P2-CBL18 *
P2-8AD4DA-2				

* Select the cable length by replacing the * with: Blank = 0.5m, -1 = 1.0m, or -2 = 2.0m.
 1. These modules are not supported by the ZIPLink wiring system.



I/O Module Installation Procedure

WARNING: DO NOT APPLY FIELD POWER UNTIL THE FOLLOWING STEPS ARE COMPLETED. SEE HOT-SWAP PROCEDURE FOR EXCEPTIONS.

Step One: Align module catch with base slot and module into connector.

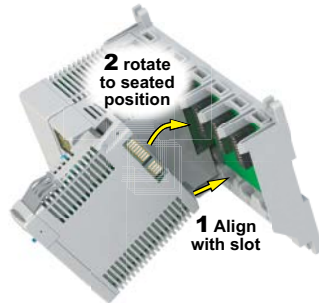

Step Two: Pull top locking tab toward module face. Click indicates lock is engaged.

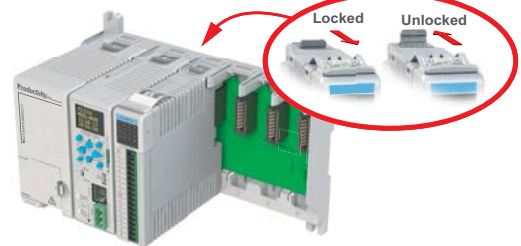

Step Three: Attach field wiring using removable terminal block or ZIPLink wiring system.



WARNING: EXPLOSION HAZARD – DO NOT CONNECT OR DISCONNECT CONNECTORS OR OPERATE SWITCHES WHILE CIRCUIT IS LIVE UNLESS THE AREA IS KNOWN TO BE NON-HAZARDOUS. DO NOT HOT-SWAP MODULES UNLESS THE AREA IS KNOWN TO BE NON-HAZARDOUS.