

proSense® Thermowells



Overview

- Thermowells designed for use with ProSense thermocouple and RTD probes or ProSense Thermometers eliminate the need for a separate probe mounting fitting or adapter

RTDTW Series Thermowells

- Welded 316 stainless steel construction
- 1/2in NPT male process threads
- 3-year warranty

TW Series Thermowells

- Drilled bar stock one piece construction (no welds) from 304 or 316 stainless steel
- 1/2in and 3/4in NPT male process threads available
- Designs and fabrication comply with ASME B31.1 and boiler and pressure vessel codes
- Material complies with NACE MR 0175 / ISO 15156
- CRN registered for all Canadian provinces
- 1-year warranty





Thermowells for Thermocouples -TW Series

Part Number	Pcs/Pkg	Wt(lb)	Price	I.D.	Overall Length/"U" Length	Male Process Threads	Female Probe Threads	Wetted Material	Temperature/Pressure Rating	Use With Probe or Thermometer
<u>TW025-01</u>	1	0.4		0.26in	2-3/4in / 1"	1/2in NPT	1/2in NPT	304 SS	304SS: 1000 °F max; 3400psi max 316SS: 1000 °F max; 5200psi max	See Sensor Compatibility Table
<u>TW025-03</u>	1	0.4				316 SS				
<u>TW04-01</u>	1	0.5			4-1/4in / 2-1/2in	1/2in NPT		304 SS		
<u>TW04-02</u>	1	0.5				3/4in NPT		304 SS		
<u>TW04-03</u>	1	0.5				1/2in NPT		316 SS		
<u>TW04-04</u>	1	0.5				3/4in NPT		316 SS		
<u>TW06-01</u>	1	0.7			6-1/4in / 4-1/2in	1/2in NPT		304 SS		
<u>TW06-02</u>	1	0.7				3/4in NPT		304 SS		
<u>TW06-03</u>	1	0.7				1/2in NPT		316 SS		
<u>TW06-04</u>	1	0.7				3/4in NPT		316 SS		
<u>TW09-01</u>	1	1.0			9-1/4in / 7-1/2in	1/2in NPT		304 SS		
<u>TW09-03</u>	1	1.0				1/2in NPT		316 SS		
<u>TW12-01</u>	1	1.2			12-1/4in / 10-1/2in	1/2in NPT		304 SS		
<u>TW12-02</u>	1	1.2				3/4in NPT		304 SS		
<u>TW12-03</u>	1	1.2				1/2in NPT		316 SS		
<u>TW12-04</u>	1	1.2				3/4in NPT		316 SS		

pro^{sense} Thermowells

Thermowells for Thermocouples -RTDTW Series										
Part Number	Pcs/Pkg	Wt(lb)	Price	I.D.	Overall Length	Male Process Threads	Female Probe Threads	Wetted Material	Temperature/Pressure Rating	Use With
<u>RTDTW-06-010-50N</u>	1	0.10		7 mm (0.28in)	113mm (4.4in)	1/2in NPT	1/4in NPT	316 SS	600 °F (315 °C) max; 232 psi (16 bar) max	XTP-160-N40140F XTP-160-0300F XTP-160-0100C RTD0100-06-010-H CF06-25N fitting
<u>RTDTW-06-020-50N</u>	1	0.20	213mm (8.4in)		XTP-260-N40140F XTP-260-0300F XTP-260-0100C RTD0100-06-020-H CF06-25N fitting					
<u>RTDTW-06-030-50N</u>	1	0.30	313mm (12.3in)		XTP-360-N40140F XTP-360-0300F XTP-360-0100C RTD0100-06-030-H CF06-25N fitting					
<u>RTDTW-10-010-50N</u>	1	0.10	11 mm (0.43in)	92mm (3.62in)	1/2in NPT					RTD0100-10-010-H CF10-50N fitting
<u>RTDTW-10-030-50N</u>	1	0.22		292mm (11.48in)						CF10-50N fitting

 Note: Check the chemical compatibility of the thermowell's wetted parts with the medium to be measured.

 Note: Response time will be slower when installed in a thermowell. Be sure to install the probe so that it contacts the end of the thermowell for faster response. Thermal compound may be used depending on application

Probe & Thermowell Assembly Example

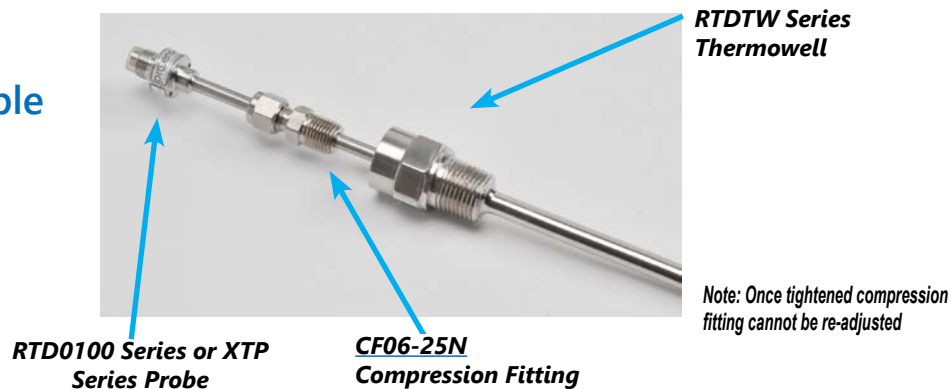

Spring-loaded Thermocouple or RTD and Thermowell Assembly Example



- Using spring-loaded probe design ensures positive tip contact with the bottom of the thermowell.
- Probes with hex nipple thread directly into thermowell. No additional probe mounting fittings are required.

proSense® Thermowells

Dimensions

inches [mm]

TW04-XX & TW025-XX

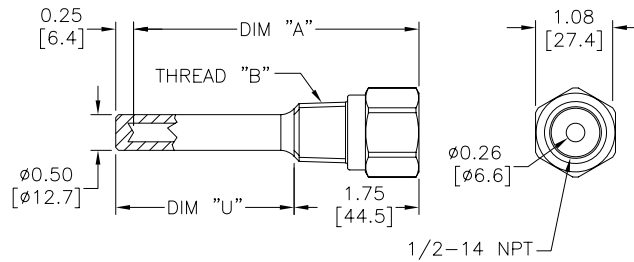

PART NUMBER	DIM "A"	THREAD "B" NPT	DIM "U"
TW025-01	2.50[63.5]	1/2-14	1.00[25.5]
TW025-03	2.50[63.5]	1/2-14	
TW04-01	4.00[101.6]	1/2-14	
TW04-02	4.00[101.6]	3/4-14	2.50[63.5]
TW04-03	4.00[101.6]	1/2-14	
TW04-04	4.00[101.6]	3/4-14	

Dimensions

inches [mm]

TW06-XX
TW09-XX
TW12-XX

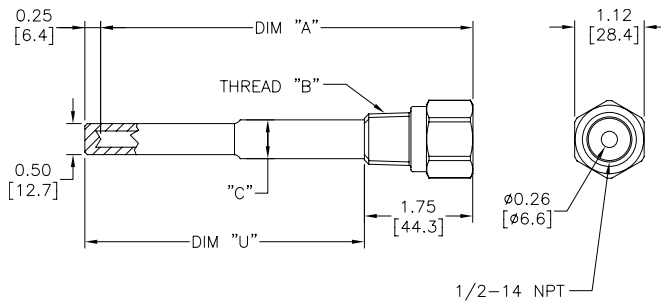

PART NUMBER	DIM "A"	THREAD "B" NPT	DIM "C"	DIM "U"
TW06-01	6.00[152.4]	1/2-14	0.63[15.9]	4.50[114.3]
TW06-02	6.00[152.4]	3/4-14	0.75[19.1]	
TW06-03	6.00[152.4]	1/2-14	0.63[15.9]	
TW06-04	6.00[152.4]	3/4-14	0.75[19.1]	7.50[190.5]
TW09-01	9.00[228.6]	1/2-14	0.63[15.9]	
TW09-03	9.00[228.6]	1/2-14	0.63[15.9]	
TW12-01	12.00[304.8]	1/2-14	0.63[15.9]	10.50[266.7]
TW12-02	12.00[304.8]	3/4-14	0.75[19.1]	
TW12-03	12.00[304.8]	1/2-14	0.63[15.9]	
TW12-04	12.00[304.8]	3/4-14	0.75[19.1]	

proSense® Thermowells

Dimensions

mm [inches]

RTDTW-06 Series

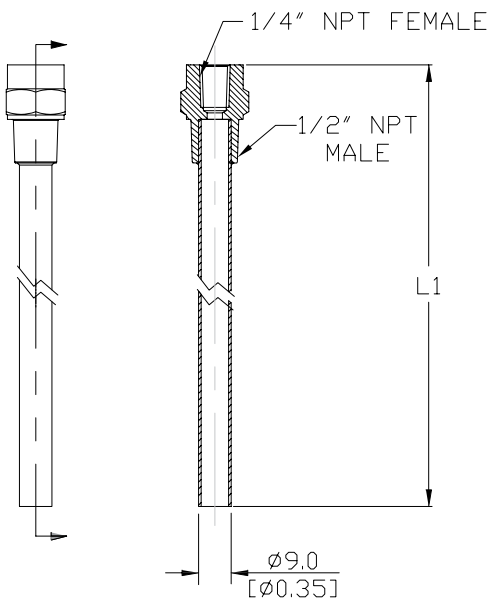

Part Number	L1
RTDTW-06-010-50N	113mm [4.4]
RTDTW-06-020-50N	213mm [8.4]
RTDTW-06-030-50N	313mm [12.3]

Torque threads to 40 lb ft [54.23 N·m]*

* Torque values are for reference. Actual torque required for a proper seal of NPT threads is influenced by tolerance, sealant, lubricant, etc.

RTDTW-10 Series

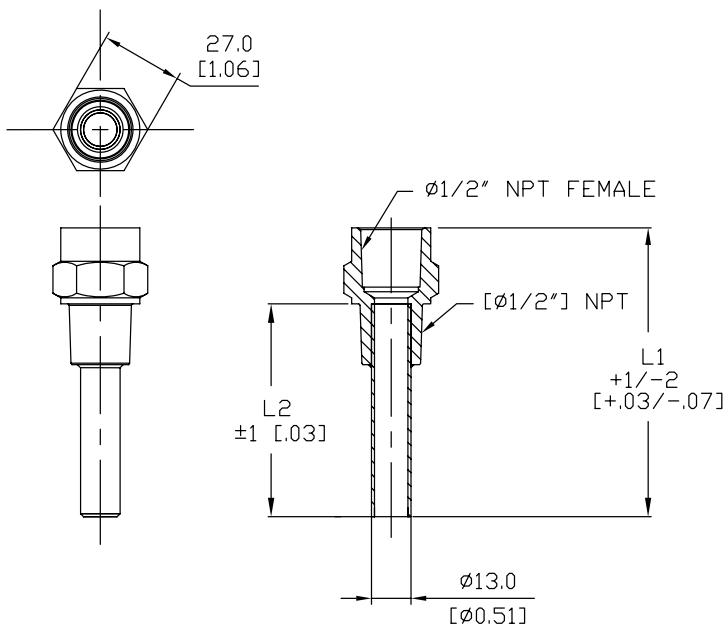









Part Number	L1	L2
RTDTW-10-030-50N	292mm [11.48]	70mm [2.75]
RTDTW-10-050-50N	292mm [11.48]	270mm [10.6]

Torque threads to 40 lb ft [54.23 N·m]*

pro^{sense} Thermowells

TW Series Thermowells Sensor Compatibility Table

Thermowell	Junction Box	Connection Head	Hex Nipple	Attached Plug	Lead Wire Transition	M12	Thermometer
							
<u>TW025-01</u> <u>TW025-03</u>	-	-	-	-	-	-	T30-N40160-25C T30-0250-25C T30-50500-25C T30-150750-25C T50-N40160-25A T50-0250-25A T50-50500-25A T50-150750-25A
<u>TW04-01</u> <u>TW04-02</u> <u>TW04-03</u> <u>TW04-04</u>	NTC10K3-JB04-03	RTD1-C04-03 THMJ-C04-03 THMK-C04-03 NTC10K3-C04-03	RTD1-H04L01-02 THMJ-H04L01-02 THMK-H04L01-02 NTC10K3-H04L01-02	RTD1-P06-01 w/ CF14-50N THMJ-P06-02 w/ CF14-50N THMK-P06-02 w/ CF14-50N NTC10K3-P06-02 w/ CF14-50N	RTD1-T06L06-01 w/ CF14-50N THMJ-T06L06-02 w/ CF14-50N THMK-T06L06-02 w/ CF14-50N NTC10K3-T06L06-02 w/CF14-50N	RTD1-50N-100-H RTD0100-06-010-H w/CF14-50N XTP-160-N40140F w/CF14-50N XTP-160-0300F w/CF14-50N XTP-160-0100C w/CF14-50N XTP50N-100-N40140F XTP50N-100-0300F XTP50N-100-0100C ETS50N-100-1001 ETS50N-100-1003	T30-N40160-4C T30-0250-4C T30-50500-4C T30-150750-4C T50-N40160-4A T50-0250-4A T50-50500-4A T50-150750-4A
<u>TW06-01</u> <u>TW06-02</u> <u>TW06-03</u> <u>TW06-04</u>	NTC10K3-JB06-03	RTD1-C06-03 THMJ-C06-03 THMK-C06-03 NTC10K3-C06-03	RTD1-H06L01-02 THMJ-H06L01-02 THMK-H06L01-02 NTC10K3-H06L01-02	RTD1-P12-01 w/ CF14-50N THMJ-P12-02 w/ CF14-50N THMK-P12-02 w/ CF14-50N NTC10K3-P12-02 w/ CF14-50N	RTD1-T12L06-01 w/ CF14-50N THMJ-T12L06-02 w/ CF14-50N THMK-T12L06-02 w/ CF14-50N NTC10K3-T12L06-02 w/CF14-50N	RTD1-50N-150-H RTD0100-06-020-H w/CF14-50N XTP-260-N40140F w/CF14-50N XTP-260-0300F w/CF14-50N XTP-260-0100C w/CF14-50N XTP50N-150-N40140F XTP50N-150-0300F XTP50N-150-0100C ETS50N-150-1001 ETS50N-150-1003	T30-N40160-6C T30-0250-6C T30-50500-6C T30-150750-6C T50-N40160-6A T50-0250-6A T50-50500-6A T50-150750-6A
<u>TW09-01</u> <u>TW09-03</u>	-	-	-	-	-	-	T50-N40160-9A T50-0250-9A T50-50500-9A T50-150750-9A
<u>TW12-01</u> <u>TW12-02</u> <u>TW12-03</u> <u>TW12-04</u>	NTC10K3-JB12-03	RTD1-C12-03 THMJ-C12-03 THMK-C12-03 NTC10K3-C12-03	RTD1-H12L01-02 THMJ-H12L01-02 THMK-H12L01-02 NTC10K3-H12L01-02	RTD1-P18-01 w/ CF14-50N THMJ-P18-02 w/ CF14-50N THMK-P18-02 w/ CF14-50N NTC10K3-P18-02 w/ CF14-50N	RTD1-T18L06-01 w/ CF14-50N THMJ-T18L06-02 w/ CF14-50N THMK-T18L06-02 w/ CF14-50N NTC10K3-T18L06-02 w/CF14-50N	RTD0100-06-030-H w/CF14-50N XTP-360-N40140F w/CF14-50N XTP-360-0300F w/CF14-50N XTP-360-0100C w/CF14-50N	-

 *Note: Response time will be slower when installed in a thermowell. Be sure to install the probe so that it contacts the end of the thermowell for faster response. Thermal compound may be used depending on application.*

proSense® Thermowells Sanitary Clean-in-Place (CIP)



STW06-01

Overview

- Sanitary Clean-In-Place 3-A approved thermowells allow the use of standard temperature sensors in hygienic applications
- All wetted parts are 316 stainless steel
- Surface finish that meets or exceeds 32 µin Ra
- Up to 1500/1200 psi (103/83 bar) at 70/250 °F (21/121 °C) dependent on clamp and seal assembly.
- Bore diameter of 0.260in to accommodate sensing probes with a 0.252in maximum diameter
- Probes with integral 1/2in male NPT process threads mount directly into the thermowell. Probes without threads require a compression fitting with 1/2in male NPT threads.



Thermowells Sanitary Clean-in-Place (CIP)									
Part Number	Pcs/Pkg	Wt(lb)	Price	I.D.	Overall Length/"U" Length	Process Connection	Female Probe Threads	Wetted Material	Use With
STW04-01	1	0.75		ø0.260	4-1/4in / 2-1/2in	1-1/2in tri-clamp	1/2in NPT	316 stainless steel	See Sensor Compatibility Table
STW06-01	1	0.88			6-1/4in / 4-1/2in				
STW12-01	1	1.13			12-1/4in / 10-1/2in				
STW04-02	1	0.75			4-1/4in / 2-1/2in	2in tri-clamp			
STW06-02	1	0.88			6-1/4in / 4-1/2in				
STW12-02	1	1.13			12-1/4in / 10-1/2in				

Note: Check the chemical compatibility of the thermowell's wetted parts with the medium to be measured.

Note: Response time will be slower when installed in a thermowell. Be sure to install the probe so that it contacts the end of the thermowell for faster response. Thermal compound may be used depending on application

Probe & Thermowell Assembly Example

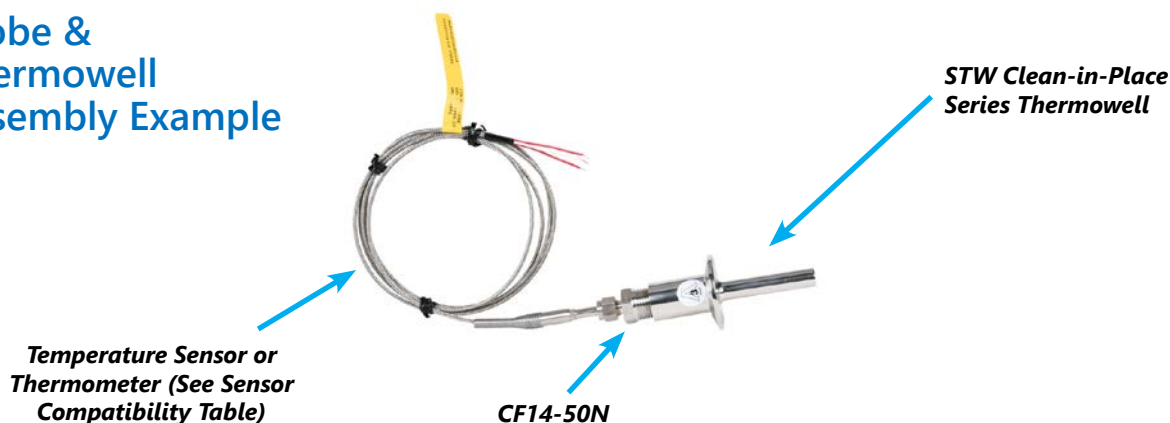

proSense® Thermowells Sanitary Clean-in-Place (CIP)

Spring-loaded Thermocouple or RTD and Thermowell Assembly Example



- Using spring-loaded probe design ensures positive tip contact with the bottom of the thermowell.
- Probes with hex nipple thread directly into thermowell. No additional probe mounting fittings are required.

Dimensions

inches [mm]

STWXX-XX

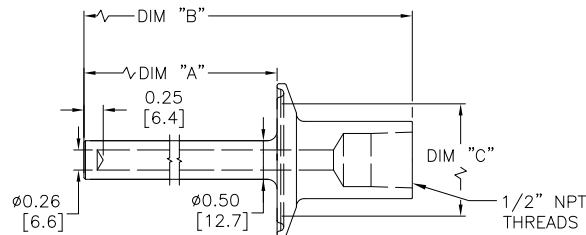









PART NUMBER	DIM "A"	DIM "B"	DIM "C"
STW04-01	2.50[63.5]	4.25[108.0]	1.50[38.1]
STW06-01	4.50[114.3]	6.25[158.8]	1.50[38.1]
STW12-01	10.50[266.8]	12.25[311.3]	1.50[38.1]
STW04-02	2.50[63.5]	4.25[108.0]	2.00[50.8]
STW06-02	4.50[114.3]	6.25[158.5]	2.00[50.8]
STW12-02	10.50[266.8]	12.25[311.3]	2.00[50.8]



Thermowells Sanitary Clean-in-Place (CIP)

Thermowells Sanitary Clean-in-Place (CIP) Sensors Compatibility Table

	Junction Box	Connection Head Sensor	Hex Nipple Sensor	Attached Plug Sensor	Lead Wire Transition Sensor	M12 Sensor	Thermometer
Thermowell							
STW04-01	NTC10K3-JB04-03	RTD1-C04-03 THMJ-C04-03 THMK-C04-03 NTC10K3-C04-03	RTD1-H04L01-02 THMJ-H04L01-02 THMK-H04L01-02 NTC10K3-H04L01-02	RTD1-P06-01 w/ CF14-50N THMJ-P06-02 w/ CF14-50N THMK-P06-02 w/ CF14-50N NTC10K3-P06-02 w/ CF14-50N	RTD1-T06L06-01 w/ CF14-50N THMJ-T06L06-02 w/ CF14-50N THMK-T06L06-02 w/ CF14-50N	RTD1-50N-100-H RTD0100-06-010-H w/CF14-50N XTP-160-N40140F w/CF14-50N XTP-160-0300F w/CF14-50N XTP-160-0100C w/CF14-50N XTP50N-100-N40140F XTP50N-100-0300F XTP50N-100-0100C ETSS50N-100-1001 ETSS50N-100-1003	T30-N40160-4C T30-0250-4C T30-50500-4C T30-150750-4C T50-N40160-4A T50-0250-4A T50-50500-4A T50-150750-4A
STW06-01	NTC10K3-JB06-03	RTD1-C06-03 THMJ-C06-03 THMK-C06-03 NTC10K3-C06-03	RTD1-H06L01-02 THMJ-H06L01-02 THMK-H06L01-02 NTC10K3-H06L01-02	RTD1-P12-01 w/ CF14-50N THMJ-P12-02 w/ CF14-50N THMK-P12-02 w/ CF14-50N NTC10K3-P12-02 w/ CF14-50N	RTD1-T12L06-01 w/ CF14-50N THMJ-T12L06-02 w/ CF14-50N THMK-T12L06-02 w/ CF14-50N	RTD1-50N-150-H RTD0100-06-020-H w/CF14-50N XTP-260-N40140F w/CF14-50N XTP-260-0300F w/CF14-50N XTP-260-0100C w/CF14-50N XTP50N-150-N40140F XTP50N-150-0300F XTP50N-150-0100C ETSS50N-150-1001 ETSS50N-150-1003	T30-N40160-6C T30-0250-6C T30-50500-6C T30-150750-6C T50-N40160-6A T50-0250-6A T50-50500-6A T50-150750-6A
STW12-01	NTC10K3-JB12-03	RTD1-C12-03 THMJ-C12-03 THMK-C12-03 NTC10K3-C12-03	RTD1-H12L01-02 THMJ-H12L01-02 THMK-H12L01-02 NTC10K3-H12L01-02	RTD1-P18-01 w/ CF14-50N THMJ-P18-02 w/ CF14-50N THMK-P18-02 w/ CF14-50N NTC10K3-P18-02 w/ CF14-50N	RTD1-T18L06-01 w/ CF14-50N THMJ-T18L06-02 w/ CF14-50N THMK-T18L06-02 w/ CF14-50N	RTD0100-06-030-H w/CF14-50N XTP-360-N40140F w/CF14-50N XTP-360-0300F w/CF14-50N XTP-360-0100C w/CF14-50N	-
STW04-02	NTC10K3-JB04-03	RTD1-C04-03 THMJ-C04-03 THMK-C04-03 NTC10K3-C04-03	RTD1-H04L01-02 THMJ-H04L01-02 THMK-H04L01-02 NTC10K3-H04L01-02	RTD1-P06-01 w/ CF14-50N THMJ-P06-02 w/ CF14-50N THMK-P06-02 w/ CF14-50N NTC10K3-P06-02 w/ CF14-50N	RTD1-T06L06-01 w/ CF14-50N THMJ-T06L06-02 w/ CF14-50N THMK-T06L06-02 w/ CF14-50N	RTD1-50N-100-H RTD0100-06-010-H w/CF14-50N XTP-160-N40140F w/CF14-50N XTP-160-0300F w/CF14-50N XTP-160-0100C w/CF14-50N XTP50N-100-N40140F XTP50N-100-0300F XTP50N-100-0100C ETSS50N-100-1001 ETSS50N-100-1003	T30-N40160-4C T30-0250-4C T30-50500-4C T30-150750-4C T50-N40160-4A T50-0250-4A T50-50500-4A T50-150750-4A
STW06-02	NTC10K3-JB06-03	RTD1-C06-03 THMJ-C06-03 THMK-C06-03 NTC10K3-C06-03	RTD1-H06L01-02 THMJ-H06L01-02 THMK-H06L01-02 NTC10K3-H06L01-02	RTD1-P12-01 w/ CF14-50N THMJ-P12-02 w/ CF14-50N THMK-P12-02 w/ CF14-50N NTC10K3-P12-02 w/ CF14-50N	RTD1-T12L06-01 w/ CF14-50N THMJ-T12L06-02 w/ CF14-50N THMK-T12L06-02 w/ CF14-50N	RTD1-50N-150-H RTD0100-06-020-H w/CF14-50N XTP-260-N40140F w/CF14-50N XTP-260-0300F w/CF14-50N XTP-260-0100C w/CF14-50N XTP50N-150-N40140F XTP50N-150-0300F XTP50N-150-0100C ETSS50N-150-1001 ETSS50N-150-1003	T30-N40160-6C T30-0250-6C T30-50500-6C T30-150750-6C T50-N40160-6A T50-0250-6A T50-50500-6A T50-150750-6A
STW12-02	NTC10K3-JB12-03	RTD1-C12-03 THMJ-C12-03 THMK-C12-03 NTC10K3-C12-03	RTD1-H12L01-02 THMJ-H12L01-02 THMK-H12L01-02 NTC10K3-H12L01-02	RTD1-P18-01 w/ CF14-50N THMJ-P18-02 w/ CF14-50N THMK-P18-02 w/ CF14-50N NTC10K3-P18-02 w/ CF14-50N	RTD1-T18L06-01 w/ CF14-50N THMJ-T18L06-02 w/ CF14-50N THMK-T18L06-02 w/ CF14-50N	RTD0100-06-030-H w/CF14-50N XTP-360-N40140F w/CF14-50N XTP-360-0300F w/CF14-50N XTP-360-0100C w/CF14-50N	-

 *Note: Response time will be slower when installed in a thermowell. Be sure to install the probe so that it contacts the end of the thermowell for faster response. Thermal compound may be used depending on application.*