

# UHZ Series Ultrasonic Sensors



## Overview

The principle of ultrasonic sensors is based on the emission of a sound impulse and the measurement of the time elapsing of the return echo signal reflected by the detected object. The ultrasonic beam is well reflected by almost all materials (metal, wood, plastic, glass, liquid, etc.) and is not affected by colored, transparent, or shiny objects.

This allows the user to standardize on one sensor for many materials without any extra setup or sensing concerns.

Measuring only 30 mm x 20 mm, these miniature sensors are specifically designed for applications with limited mounting space. Through-beam pair sensors are often the most accurate and reliable sensor configurations, but can also be the most costly when compared to traditional diffuse or retroreflective sensors. The low price of a UHZ series through-beam pair allows it to be a competitive alternative to similarly priced but less accurate sensors.

Ultrasonic sensors (rectangular) are ideal for detecting objects in applications where the use of a normal photocell does not, such as:

- level measurement: for tanks containing solid or liquid
- diameter or loop detection: for materials such as paper, sheet iron, etc.
- transparent object detection: for plastic or glass bottles, plastic filters, etc.

Ultrasonic Through-Beam Sensors Specifications	
Specifications	UHZ
Nominal Sensing Distance	300 mm [11.81 in]
Operating Distance	NA
Output Type	PNP/NPN, N.O./ N.C.
Operating Voltage	18 - 30 VDC
No Load Supply Current	< 40mA
Operating (Load) Current	500mA
Off-state (Leakage) Current	< 10µA @ 30 VDC
Voltage Drop	NA
Switching Frequency	150Hz
Sensing Beam	Beam angle 15°
Differential Travel (% of Nominal Distance)	NA
Repeat Accuracy	NA
Ripple	NA
Time Delay Before Availability (tv)	NA
Response Time	1ms
Reverse Polarity Protection	Yes
Short-Circuit Protection	Output short circuit and over current protection, reverse polarity protection
Operating Temperature	5 to 140°F [-15 to +60°C]
Protection Degree	IEC-IP67
Indication/Switch Status	Yellow Output State
Case Material	PBTP
Active Head Material	Ceramic
Shock/Vibration	per IEC EN 60947-5-2
Tightening Torque	NA
Weight	161g (5.68 oz)
Connection	2m [6.5 ft] axial cable
Agency Approvals	CE

# UHZ Series Ultrasonic Sensors

## Overview

The UHZ series of miniature ultrasonic sensors includes four models of rectangular through-beam units. These tiny 20 mm x 30 mm sensors have a maximum sensing distance of 300 mm, with no dead zone at close range. This enables object sensing at a variety of distances. All models have an LED indicator on the receiver and are IP67 protection rated.

With two pre-drilled mounting holes, the UHZ units can be surface mounted more easily than traditional 18 mm or 30 mm threaded tubular designs, which often require a separate mounting bracket or a large mounting hole and additional locknuts.

## Features

- 30x20x12 mm emitter/receiver rectangular ultrasonic sensor
- LED status indicator for all models
- Complete protection against electrical damage
- IP67 protection
- Strong plastic housing
- Switching frequency 150 Hz
- Sensing distance (sn): 300mm
- Beam angle: 15°
- Supply voltage: 18 - 30 VDC
- NPN or PNP, N.O. or N.C. models
- Lifetime warranty

Rectangular Ultrasonic Through-Beam Sensors Selection Chart									
Part Number	Price	Voltage Range	Sensing Range	Switching Frequency	Sensing Beam	Through-Beam Component	Output Type	Connection Type	Wiring
<a href="#">UHZ-AN-0A</a>		18 - 30 VDC	11.81 in [0.3 m]	150Hz	Ultrasonic	pair	NPN /N.O.	2m [6.5 ft] cable	Diagram 1
<a href="#">UHZ-AP-0A</a>	pair					PNP / N.O.	Diagram 2		
<a href="#">UHZ-CN-0A</a>	pair					NPN /N.C.	Diagram 3		

## Wiring Diagram

### Emitter

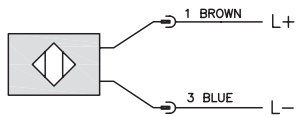

### Receiver (NPN) Diagram 1

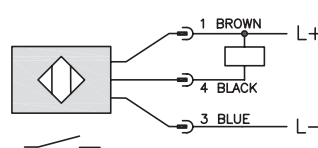

### Receiver (PNP) Diagram 2

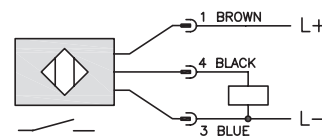

### Receiver (NPN) Diagram 3

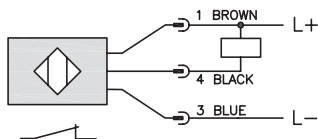

## Dimensions

mm [inch]

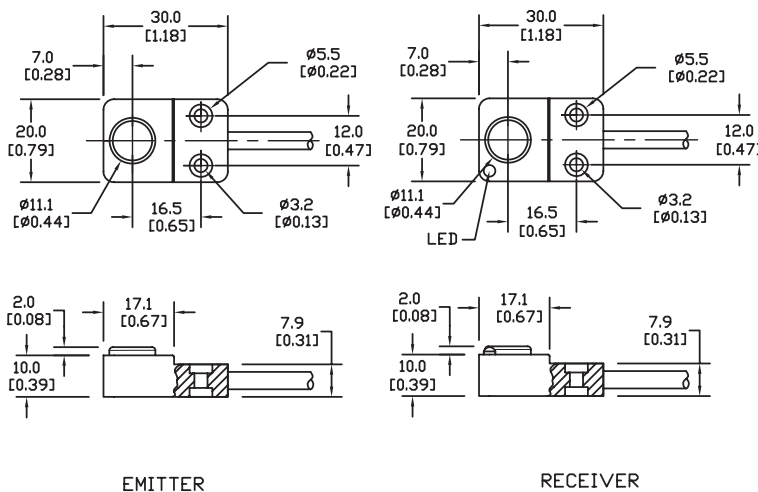

*Warning: These products are not safety sensors and are not suitable for use in personal safety applications.*