



# D-Series Heavy Duty Pneumatic Cylinders

## 2-1/2 inch Bore

2-1/2 in. Bore, Double-acting, Tapped End Caps, Magnetic Piston



Part no. D40060DT-M

NITRA heavy duty pneumatic, NFPA interchangeable cylinder, 2-1/2 inch bore, 5/8" diameter piston rod, 1/4" NPT ports, double acting, tapped end caps and one side for mount, flange, pivot and clevis mount options available.

2-1/2 in bore, double acting, tapped end caps				
Part Number	Stroke Length (in.)	"A" (in [mm])	Weight (lbs)	Price
D40010DT-M	1	4.75 [120.6]	3.4	<--->
D40020DT-M	2	5.75 [146.0]	3.7	<--->
D40030DT-M	3	6.75 [171.4]	3.9	<--->
D40040DT-M	4	7.75 [196.8]	4.2	<--->
D40050DT-M	5	8.75 [222.2]	4.4	<--->
D40060DT-M	6	9.75 [247.6]	4.7	<--->
D40070DT-M	7	10.75 [273.0]	5.0	<--->
D40080DT-M	8	11.75 [298.4]	5.2	<--->
D40090DT-M	9	12.75 [323.8]	5.5	<--->
D40100DT-M	10	13.75 [349.2]	5.8	<--->
D40110DT-M	11	14.75 [374.6]	6.0	<--->
D40120DT-M	12	15.75 [400.0]	6.3	<--->
D40140DT-M	14	17.75 [450.8]	6.8	<--->
D40160DT-M	16	19.75 [501.6]	7.3	<--->
D40180DT-M	18	21.75 [552.4]	7.8	<--->
D40200DT-M	20	23.75 [603.2]	8.4	<--->
D40220DT-M	22	25.75 [654.0]	8.9	<--->
D40240DT-M	24	27.75 [704.8]	9.1	<--->

Specifications	
Aluminum hard anodized to 60 Rc cylinder body	4.91 sq. in. piston area
Solid aluminum bar, black anodized end caps	Pressure rating 250 psi, <b>AIR ONLY</b>
High tensile ground and polished hard chrome plated steel piston rod	Non-detergent petroleum based oil is recommended
Low friction Buna-N seals	Temperature range -40°F to 250°F (-40 to 121°C)
Extend force at 100 psi = 491 lb.	Retract force at 100 psi = 460 lb.
Filtration: Not essential, however a standard 40 micron filter placed upstream will prolong seal life.	

Mounting Accessories		
Style	NFPA Designation	Part No.
Front Flange	MF1	DFM-3
Rear Flange	MF2	DFM-3
Rear Clevis	MP2	DPC-3
Rear Pivot	MP4	DPA-3

Rod Accessories	
Style	Part No.
Rod Clevis	DRC-2
Rod Pivot	DRE-1

Dimensions: in [mm]

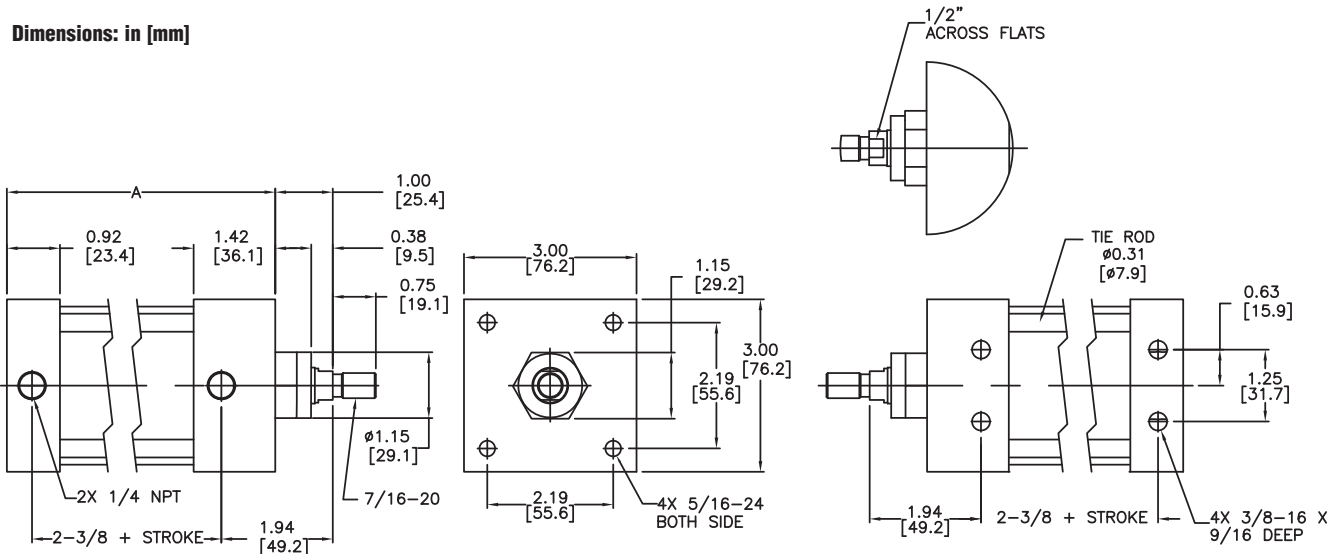

## Nitra Heavy Duty Pneumatic Air Cylinders

The NITRA Pneumatics D-Series heavy duty cylinders include bore sizes from 1-1/2" to 4" and stroke lengths from 1" to 24" to meet a broad range of applications where abusive conditions exist. These heavy duty cylinders are constructed with high quality aluminum components and a magnetic piston fitted with a PTFE Wear Band.

The cylinders are fitted with a Teflon® impregnated and hardcoat anodized heavy-duty external rod bearing. This bearing ensures smooth rod motion while maintaining rod rigidity and stability. The entire rod gland and bearing may be quickly removed and replaced without disassembling the cylinder.

All D-Series cylinders have a magnetic piston that can be used along with solid state or reed switches for rod position sensing. The solid state and reed switches sense the rod position by emitting an electrical signal when the magnetized piston reaches a point adjacent to their location. Tie rod mounting allows fast and accurate positioning setup.

## Mounting Options

### Flange Mounted:

The cylinder has holes on the ends of the end caps that allow easy mounting to a plate or other surfaces. See Flange Mount Kits in Accessories section.

#### Front Flange Mount (MF1)

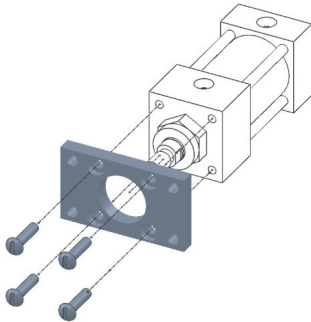

#### Rear Flange Mount (MF2)

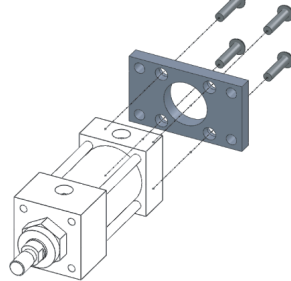

### Side Mounted:

The cylinder has holes on the sides of the end caps that allow easy mounting to a surface. No mounting kit needed, only bolts.

#### Tapped Side Flange Mount (MS4)

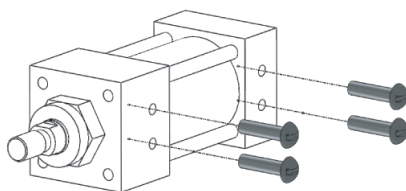

## Features

- Interchangeable with other popular brands of NFPA cylinders
- Available bore sizes: 1-1/2", 2", 2-1/2", 3-1/4", 4"
- Excellent selection of stroke lengths
- All models are double-acting
- Head and tail caps drilled for mounting
- All models have a magnetic piston
- Teflon® impregnated and hardcoat anodized heavy-duty external rod bearing
- 250 psi max operating pressure
- All models are available for same-day shipment
- Made in the USA

## Operation

**Double-acting cylinders** have two compressed air ports. One of the ports will extend the rod in the "push" direction and the other port will retract the rod in the "pull" direction.

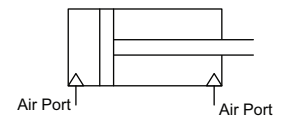

**Double-Acting Cylinder**  
(Force in Push and Pull Direction)

### Rear Clevis and Rear Pivot Mount:

Clevis and Pivot mounts use a bracket that allows a pivoted mount. See Rear Clevis and Pivot Attachments in Accessories section.

#### Rear Clevis Mount (MP2)

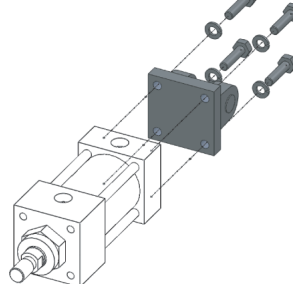

#### Rear Pivot Mount (MP4)

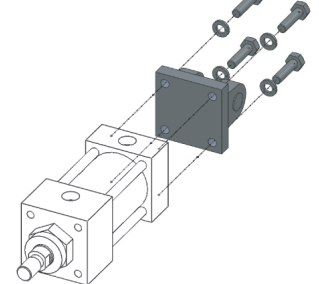

### Rod Clevis:

This Clevis uses a rod-mounted bracket and pin that allows a pivoted mount. **Rod Eye** uses a rod-mounted block with eye that allows a pivoted mount. See Rod Clevis and Rod Eye in Accessories Section.

#### Rod Clevis

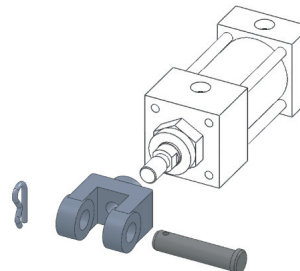

#### Rod Eye

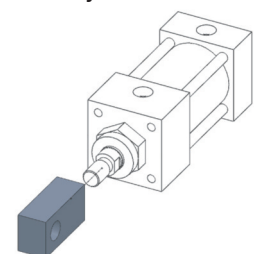



# D-Series Heavy Duty Pneumatic Cylinders

## Cylinder Features

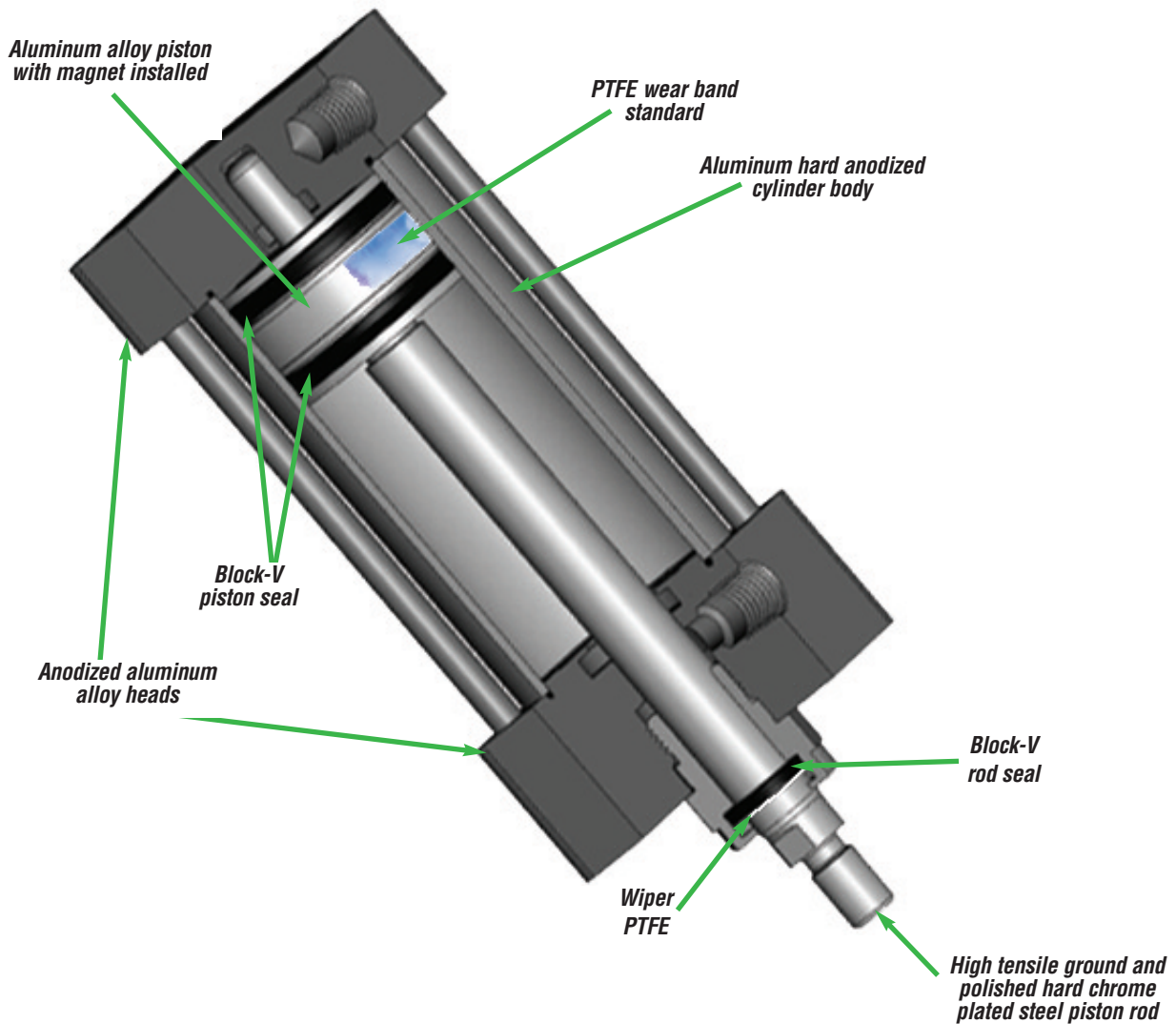



# D-Series Heavy Duty Pneumatic Cylinders Accessories

D-Series Heavy Duty Pneumatic Cylinder Accessories					
Part Number	Description	Pcs/Pkg	Wt (lb)	Price	
<b>DRC-2</b>	Cylinder rod clevis, 7/16-20 thread, for use with 1-1/2, 2 and 2-1/2 inch bore NITRA NFPA D-series pneumatic cylinders	1	0.6	<--->	Field I/O
<b>DRC-4</b>	Cylinder rod clevis, 3/4-16 thread, for use with 3-1/4 and 4 inch bore NITRA NFPA D-series pneumatic cylinders	1	1.6	<--->	Software
<b>DRE-1</b>	Cylinder rod eye, 7/16-20 thread, for use with 1-1/2, 2 and 2-1/2 inch bore NITRA NFPA D-series pneumatic cylinders	1	0.4	<--->	C-more & other HMI
<b>DRE-2</b>	Cylinder rod eye, 3/4-16 thread, for use with 3-1/4 and 4 inch bore NITRA NFPA D-series pneumatic cylinders	1	1.2	<--->	Drives
<b>DPC-1</b>	NFPA style MP2 cylinder rear clevis bracket and attaching hardware, for use with 1-1/2 inch bore NITRA NFPA D-series pneumatic cylinders	1	0.5	<--->	Soft Starters
<b>DPC-2</b>	NFPA style MP2 cylinder rear clevis bracket and attaching hardware, for use with 2 inch bore NITRA NFPA D-series pneumatic cylinders	1	0.7	<--->	Motors & Gearbox
<b>DPC-3</b>	NFPA style MP2 cylinder rear clevis bracket and attaching hardware, for use with 2-1/2 inch bore NITRA NFPA D-series pneumatic cylinders	1	0.8	<--->	Steppers/ Servos
<b>DPC-4</b>	NFPA style MP2 cylinder rear clevis bracket and attaching hardware, for use with 3-1/4 inch bore NITRA NFPA D-series pneumatic cylinders	1	1.6	<--->	Motor Controls
<b>DPC-5</b>	NFPA style MP2 cylinder rear clevis bracket and attaching hardware, for use with 4 inch bore NITRA NFPA D-series pneumatic cylinders	1	1.7	<--->	Proximity Sensors
<b>DPA-1</b>	NFPA style MP4 cylinder rear pivot eye and attaching hardware, for use with 1-1/2 inch bore NITRA NFPA D-series pneumatic cylinders	1	0.4	<--->	Photo Sensors
<b>DPA-2</b>	NFPA style MP4 cylinder rear pivot eye and attaching hardware, for use with 2 inch bore NITRA NFPA D-series pneumatic cylinders	1	0.5	<--->	Limit Switches
<b>DPA-3</b>	NFPA style MP4 cylinder rear pivot eye and attaching hardware, for use with 2-1/2 inch bore NITRA NFPA D-series pneumatic cylinders	1	0.7	<--->	Encoders
<b>DPA-4</b>	NFPA style MP4 cylinder rear pivot eye and attaching hardware, for use with 3-1/4 inch bore NITRA NFPA D-series pneumatic cylinders	1	1.3	<--->	Current Sensors
<b>DPA-5</b>	NFPA style MP4 cylinder rear pivot eye and attaching hardware, for use with 4 inch bore NITRA NFPA D-series pneumatic cylinders	1	1.4	<--->	Pressure Sensors
<b>DFM-1</b>	NFPA style MF1 or MF2 cylinder flange mounting plate and attaching hardware, for use with 1-1/2 inch bore NITRA NFPA D-series pneumatic cylinders	1	0.3	<--->	Temperature Sensors
<b>DFM-2</b>	NFPA style MF1 or MF2 cylinder flange mounting plate and attaching hardware, for use with 2 inch bore NITRA NFPA D-series pneumatic cylinders	1	0.4	<--->	Pushbuttons/ Lights
<b>DFM-3</b>	NFPA style MF1 or MF2 cylinder flange mounting plate and attaching hardware, for use with 2-1/2 inch bore NITRA NFPA D-series pneumatic cylinders	1	0.5	<--->	Process
<b>DFM-4</b>	NFPA style MF1 or MF2 cylinder flange mounting plate and attaching hardware, for use with 3-1/4 inch bore NITRA NFPA D-series pneumatic cylinders	1	3.0	<--->	Relays/ Timers
<b>DFM-5</b>	NFPA style MF1 or MF2 cylinder flange mounting plate and attaching hardware, for use with 4 inch bore NITRA NFPA D-series pneumatic cylinders	1	4.3	<--->	Comm.

## Rod Clevis

Dimensions: in [mm]

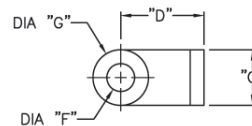
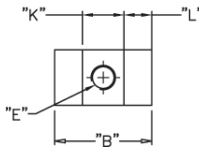
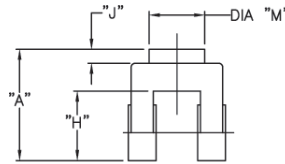

**Note: Comes with Pivot Pin installed.**

Rod Clevis Dimension Table

Part #	A	B	C	D	E	(Dia) F	(Dia) G	H	J	K	L	M
DRC-2	2.00 [50.8]	1.75 [44.5]	1.00 [25.4]	1.50 [38.1]	7/16-20	ø0.50 [ø12.7]	ø1.00 [ø25.4]	1.25 [31.8]	0.25 [6.4]	0.75 [19.1]	0.50 [12.7]	ø1.00 [ø25.4]
DRC-4	3.13 [79.5]	2.50 [63.5]	1.50 [38.1]	2.38 [60.5]	3/4-16	ø0.75 [ø19.1]	ø1.50 [ø38.1]	2.00 [50.8]	0.31 [7.8]	1.25 [31.8]	0.63 [16.0]	ø1.50 [ø38.1]

## Rod Eye

Dimensions: in [mm]

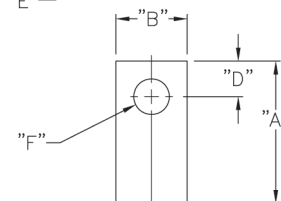
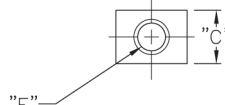

Rod Eye Dimension Table

Part #	A	B	C	D	E	(Dia) F
DRE-1	2.00 [50.8]	1.00 [25.4]	0.75 [19.1]	0.50 [12.7]	7/16-20 x 3/4	ø0.50 [ø12.7]
DRE-2	2.81 [71.4]	1.50 [38.1]	1.25 [31.8]	0.75 [19.1]	3/4-16 x 1-1/18	ø0.75 [ø19.1]

## Rear Clevis

Dimensions: in [mm]

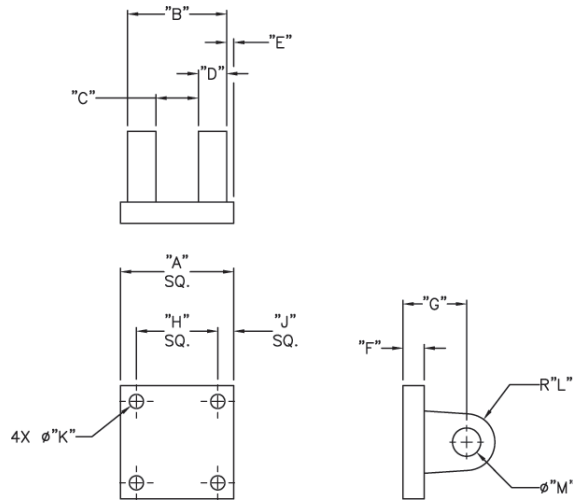

**Note: Comes with Pivot Pin installed.**

**Rear Clevis Dimension Table**

Part #	A	B	C	D	E	F	G	H	J	(Dia) K	(R) L	(Dia) M
DPC-1	2.00 [50.8]	1.75 [44.5]	0.75 [19.1]	0.50 [12.7]	0.13 [3.3]	0.38 [9.7]	1.13 [28.7]	1.44 [36.6]	0.28 [7.1]	ø0.27 [ø6.9]	R 0.50 [R 12.7]	ø0.50 [ø12.7]
DPC-2	2.50 [63.5]	1.75 [44.5]	0.75 [19.1]	0.50 [12.7]	0.38 [9.7]	0.38 [9.7]	1.13 [28.7]	1.84 [46.7]	0.33 [8.4]	ø0.36 [ø9.1]	R 0.50 [R 12.7]	ø0.50 [ø12.7]
DPC-3	3.00 [76.2]	1.75 [44.5]	0.75 [19.1]	0.50 [12.7]	0.63 [16.0]	0.38 [9.7]	1.13 [28.7]	2.19 [55.6]	0.41 [10.4]	ø0.36 [ø9.1]	R 0.50 [R 12.7]	ø0.50 [ø12.7]
DPC-4	3.75 [95.3]	2.63 [66.8]	1.25 [31.8]	0.63 [16.0]	0.63 [16.0]	0.63 [16.0]	1.88 [47.8]	2.75 [69.9]	0.50 [12.7]	ø0.44 [ø11.2]	R 0.75 [R 19.1]	ø0.75 [ø19.1]
DPC-5	4.50 [114.3]	2.63 [66.8]	1.25 [31.8]	0.63 [16.0]	1.00 [25.4]	0.63 [16.0]	1.88 [47.8]	3.33 [84.6]	0.59 [15.0]	ø0.44 [ø11.2]	R 0.75 [R 19.1]	ø0.75 [ø19.1]

## Rear Pivot Eye

Dimensions: in [mm]

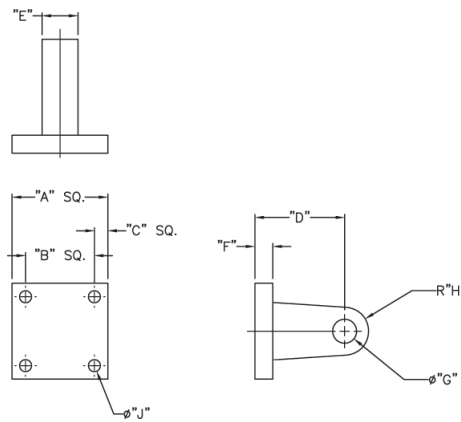

**Rear Pivot Eye Dimension Table**

Part #	A	B	C	D	E	F	(Dia) G	(R) H	(Dia) J
DPA-1	2.00 [50.8]	1.44 [36.6]	0.28 [7.1]	1.13 [28.7]	0.75 [19.1]	0.38 [9.70]	ø0.50 [ø12.7]	R 0.50 [R 12.7]	ø0.27 [ø6.9]
DPA-2	2.50 [63.5]	1.84 [46.7]	0.33 [8.4]	1.13 [28.7]	0.75 [19.1]	0.38 [9.70]	ø0.50 [ø12.7]	R 0.50 [R 12.7]	ø0.36 [ø9.1]
DPA-3	3.00 [76.2]	2.19 [55.6]	0.41 [10.4]	1.13 [28.7]	0.75 [19.1]	0.38 [9.70]	ø0.50 [ø12.7]	R 0.50 [R 12.7]	ø0.36 [ø9.1]
DPA-4	3.75 [95.3]	2.75 [69.9]	0.50 [12.7]	1.88 [47.8]	1.25 [31.8]	0.63 [16.0]	ø0.75 [ø19.1]	R 0.75 [R 19.1]	ø0.44 [ø11.2]
DPA-5	4.50 [114.3]	3.33 [84.6]	0.59 [15.0]	1.88 [47.8]	1.25 [31.8]	0.63 [16.0]	ø0.75 [ø19.1]	R 0.75 [R 19.1]	ø0.44 [ø11.2]

## Flange Attachment

Dimensions: in [mm]

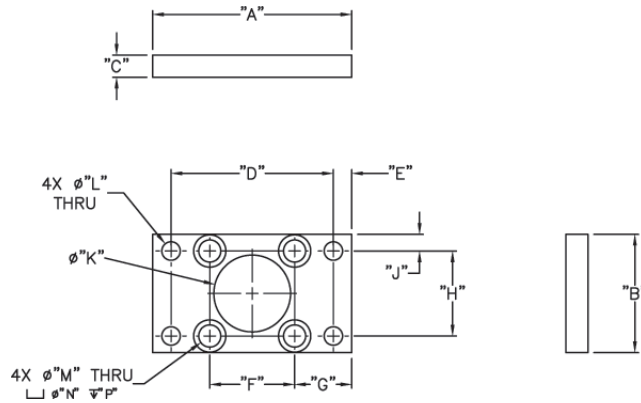

**Flange Attachment Dimension Table**

Part #	A	B	C	D	E	F	G	H	J	(Dia) K	(Dia) L	(Dia) M	(Dia) N	P
DFM-1	3.38 [85.9]	2.00 [50.8]	0.38 [9.7]	2.75 [69.9]	0.31 [7.9]	1.44 [36.6]	0.97 [24.6]	1.44 [36.6]	0.28 [7.1]	ø1.30 [ø33.0]	ø0.31 [ø7.9]	ø0.38 [ø9.7]	ø0.66 [ø16.8]	0.16 [4.1]
DFM-2	4.13 [104.9]	2.50 [63.5]	0.38 [9.7]	3.38 [85.9]	0.38 [9.7]	1.84 [46.7]	1.14 [29.0]	1.84 [46.7]	0.33 [8.4]	ø1.30 [ø33.0]	ø0.38 [ø9.7]	ø0.38 [ø9.7]	ø0.66 [ø16.8]	0.16 [4.1]
DFM-3	4.63 [117.6]	3.00 [76.2]	0.38 [9.7]	3.88 [98.6]	0.38 [9.7]	2.19 [55.6]	1.22 [31.0]	2.19 [55.6]	0.41 [10.4]	ø1.74 [ø44.2]	ø0.38 [ø9.7]	ø0.38 [ø9.7]	ø0.66 [ø16.8]	0.16 [4.1]
DFM-4	5.50 [139.7]	3.75 [95.3]	0.63 [16.0]	4.69 [119.1]	0.41 [10.4]	2.75 [69.9]	1.38 [35.1]	2.75 [69.9]	0.50 [12.7]	ø2.03 [ø51.6]	ø0.44 [ø11.2]	ø0.40 [ø10.2]	ø0.75 [ø19.8]	ø0.36 [ø9.1]
DFM-5	6.25 [158.8]	4.50 [114.3]	0.63 [16.0]	5.44 [138.2]	0.41 [10.4]	3.33 [84.6]	1.46 [37.1]	3.33 [84.6]	0.59 [15.0]	ø2.03 [ø51.6]	ø0.44 [ø11.2]	ø0.40 [ø10.2]	ø0.78 [ø19.8]	ø0.36 [ø9.1]