

WC10 NEMA 12 and 13 Operator Consoles



Applications

Designed to hold electrical and electronic controls and instruments. Heavy-duty construction provides protection from dirt, dust, oil and water. Pushbuttons, pilot lights, meters, switches, etc. can be mounted on sloping control surfaces. Interior components can be mounted on subpanel and terminal straps.

Construction

Base

- Fabricated from 14-gauge steel
- Seams are continuously-welded and ground smooth
- 3-point keylocking handle is provided on front, main door
- Flush main door
- Control panels are hinged along bottom edge
- Control panels have captivated screws threaded into sealed wells
- Door stops provided to hold control panel open
- Standard closed-cell neoprene gasket
- Removable subpanel is included with enclosure
- Grounding provisions provided
- Uses WAL2 series handles and WAL2KEY replacement key

Top

- Fabricated from 14-gauge steel
- Seams are continuously-welded and ground smooth
- Instrument and access panels have captivated screws that thread into sealed wells
- Closed-cell neoprene gasket

Writing desk

- Fabricated from 14-gauge steel
- Seams are continuously-welded and ground smooth
- Desks are removable and attach easily to console front

Finish

- ANSI 61 gray polyester powder inside and out over phosphatized surfaces
- Included painted steel subpanel is white polyester powder over phosphatized surfaces

Listings

- UL 508 12 and 13 [UL File E64791]
- NEMA/EEMAC 12 and 13



Shipping Schedule

Same day 1 - 5 days 1 - 7 days 1-10 days 1 - 15 days 1 - 20 days

Color indicates shipping lead time in business days.

WC10 NEMA 12 and 13 Operator Consoles

| Part Number | Price | Enclosure SizeHxWxD | Description |
|-------------|---------|--|---|
| WC10B | Retired | 40.13 x 24.13 x 20.12 [1019 x 613 x 511] | Console base |
| WC10T | Retired | 16.15 x 24.15 x 5.13 [410 x 614 x 130] | Console top for WC10B |
| WC10W | Retired | 3.00 x 24.13 x 10.13 [76 x 613 x 26] | Writing desk for WC10B |
| WC10C | Retired | — | Caster kit: Set of 4 casters, 2 mounting plates, and hardware |

Notes: Dimensions in inches [millimeters].

Letters in table correspond to letters on dimensional drawings.

*Subpanel is included with console.

Tops, writing desks and caster kits must be ordered separately.

WC12 NEMA 12 and 13 Operator Consoles



Dimensions

in mm

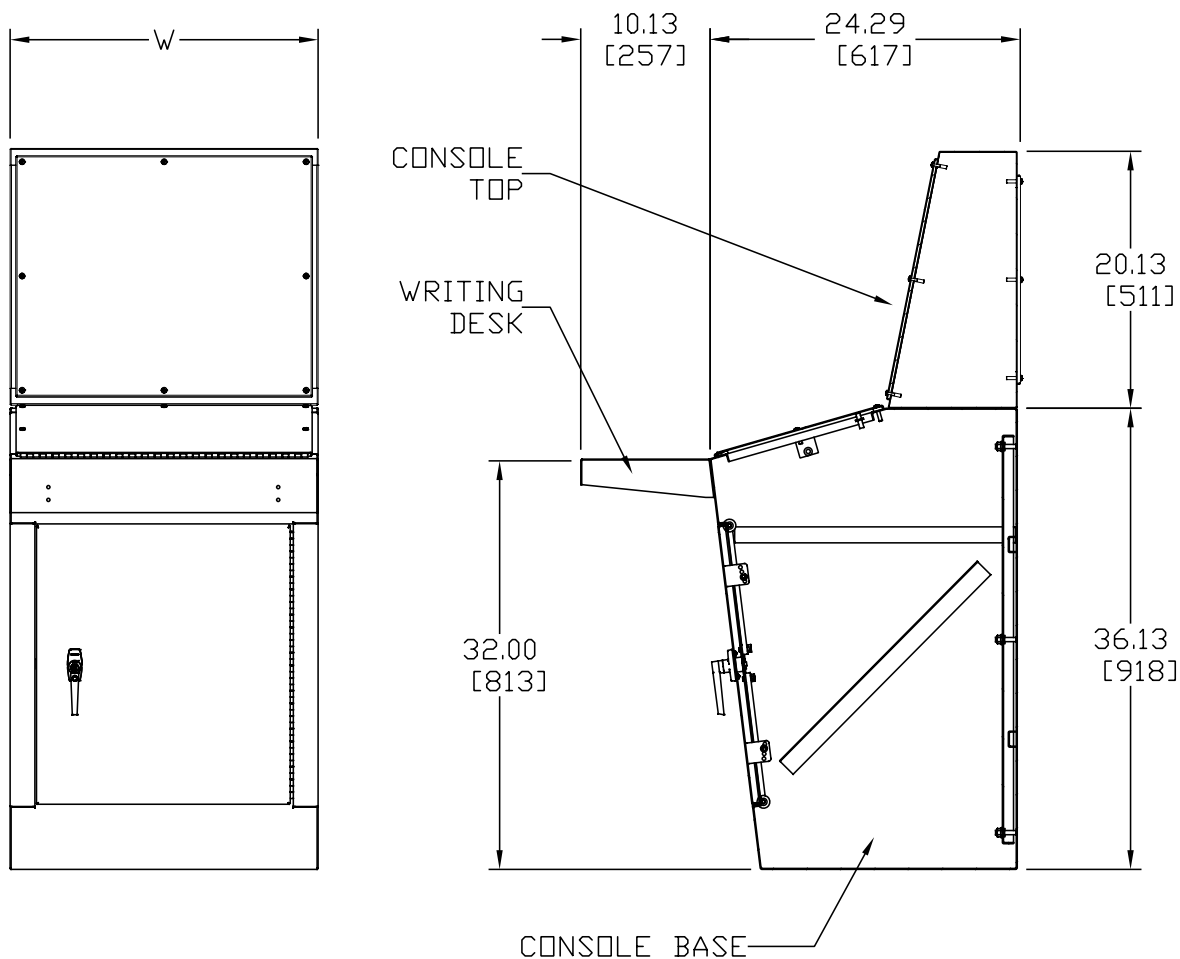

NOTES:

1. ACCESS DOORS OPEN 180 DEGREES.
2. 3-POINT KEY LOCKING HANDLES ARE PROVIDED ON MAIN DOORS
3. WRITING DESK IS PROVIDED WITH MOUNTING HARDWARE.
4. 48" WIDE CONSOLE HAS TWO DOORS.

Enclosure Accessories – Mounting Feet and Casters

Mounting Feet for Ultimate Series Enclosures



Shipping Schedule

Same day 1 - 5 days 1 - 7 days 1 - 15 days 1 - 20 days

Color indicates shipping lead time in business days.

| Mounting Feet | Price | Description | Wt. [lb] |
|-------------------------|-------|---|----------|
| <u>N412MFK</u> | – | Wiegmann mounting feet kit, plated finish. For use on NEMA 412 Ultimate series enclosures. Includes (4) mounting feet, mounting hardware and sealing washers. | 4 |
| <u>N412MFKSS</u> | – | Wiegmann mounting feet kit, 304 stainless steel. For use on NEMA 412 Ultimate series enclosures. Includes (4) mounting feet, mounting hardware and sealing washers. | 4 |



N412MFK



N412MFKSS

Casters

Casters can be used on any enclosure to provide mobility. Caster kits include mounting plates designed to fit Wiegmann WC10 and WC12 consoles, but can be adapted to fit other enclosures.

| Caster Kit | Price | Description | Wt. [lb] | Capacity [lb] |
|---------------------|---------|---|----------|---------------|
| <u>WC10C</u> | Retired | Wiegmann caster kit, for WC10 consoles. Includes 4 zinc-plated steel casters (2 swivel, 2 stationary), 2 ANSI 61 gray mounting plates and hardware. | 4 | 200 |
| <u>WC12C</u> | Retired | Wiegmann caster kit, for WC12 consoles. Includes 4 zinc-plated steel casters (2 swivel, 2 stationary), 2 ANSI 61 gray mounting plates and hardware. | 4 | 200 |



WC12C

Enclosure Accessories – Locks and Latches

Latch Kits for Single Door NEMA 3R, NEMA 4, and NEMA 12 Enclosures



Shipping Schedule

Same day 1 - 5 days 1 - 7 days 1 - 15 days 1 - 20 days

Color indicates shipping lead time in business days.

Latch Kits for Single Door NEMA 3R and NEMA 12 Enclosures

| Padlock Style | Price | Wt. [lb] | Keylock Style | Price | Wt. [lb] | Description |
|---------------|---------|----------|----------------|---------|----------|---|
| WAL1A | Retired | 1.7 | WAL2A | Retired | 0.9 | Wiegmann enclosure latch kit, 1-point. For use on single door NEMA 12 enclosures. |
| WAL1B | Retired | 2.8 | WAL2B | Retired | 2.0 | Wiegmann enclosure latch kit, 3-point. For use on NEMA 12 enclosures where height is 16, 20, 24 or 30 inches. |
| WAL1C | — | 3.8 | WAL2C | Retired | 2.8 | Wiegmann enclosure latch kit, 3-point. For use on NEMA 12 enclosures where height is 36, 42 or 48 inches. |
| WAL1D | — | 4.8 | WAL2D | Retired | 4.0 | Wiegmann enclosure latch kit, 3-point. For use on NEMA 12 enclosures where height is 60 or 72 inches. |
| — | — | — | WAL2KEY | Retired | 0.1 | Wiegmann enclosure key, replacement, for WAL2A, WAL2B, WAL2C, WAL2D locks. |

Enclosures

The locks and lock kits on this page are used with the following enclosure series: CTDD

- WA_WF

Enclosure series example:

Enclosure part number WA364812WF = WA_WF series



WAL2A



WAL1A

Enclosure Accessories – Mounting Feet, Panel Mounting and Latches

Mounting Feet for Freedom, Commander and Centurion Series Enclosures



| Mounting Feet for Freedom, Commander and Centurion Series Enclosures | | | |
|--|---------|---|----------|
| Mounting Foot Kit | Price | Description | Wt. [oz] |
| <u>FRMGFTKIT</u> | Retired | Mounting feet kit, fiberglass-reinforced polyester, for use on Freedom series enclosures. Includes (4) mounting feet and mounting hardware. | 1 |
| <u>COMTGFTKIT</u> | Retired | Mounting feet kit, fiberglass-reinforced polyester, for use on Commander series fiberglass, in-line, pushbutton enclosures. Does not fit CO763, CO963, COxPBW series, and COPCxxx series, COPCxPB series, and COPCxPB22 series enclosures. Includes (2) mounting feet, mounting hardware and silicone adhesive/sealant. | 1 |
| <u>CEMTGFTKIT</u> | Retired | Mounting feet kit, fiberglass-reinforced polyester, for use on Centurion series enclosures. Includes (4) mounting feet and mounting hardware. | 1 |

| Shipping Schedule | | | | |
|--|------------|------------|-------------|-------------|
| Same day | 1 - 5 days | 1 - 7 days | 1 - 15 days | 1 - 20 days |
| Color indicates shipping lead time in business days. | | | | |

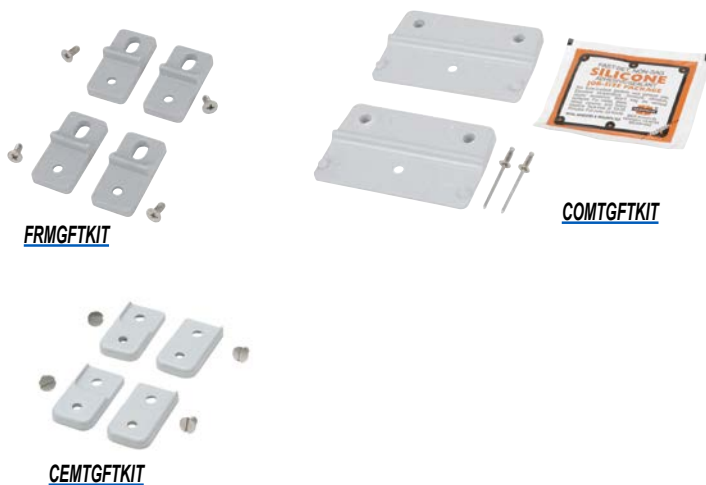

Swing-panel Mounting Kit for MachoBox Series Enclosures

| Swing-panel Mounting Kit for MachoBox Series Enclosures | | | |
|---|---------|---|----------|
| Mounting Foot Kit | Price | Description | Wt. [oz] |
| <u>M3024SPMK</u> | Retired | Swing-panel mounting kit, fiberglass-reinforced polyester, for use on 30x24in [762x610mm] MachoBox enclosures and subpanels. Includes (8) mounts and (16) screws. | 7 |



Latches For Centurion, Freedom, and Triton Series Enclosures



| Latches for Centurion, Freedom, and Triton Series Enclosures | | |
|--|---------|--|
| Latch | Price | Description |
| <u>SSLKIT</u> | — | Centurion series luggage style Stainless Steel lockable latch. |
| <u>FRHLLKIT</u> | Retired | Freedom series lockable link latch. |
| <u>TLL150KIT</u> | Retired | Triton Series twist-lock latch. For 12, 3R, and 4X. |
| <u>TLL150WTKIT</u> | Retired | Triton Series twist-lock latch. For 4X top and bottom latches. |