

Hammond Transformers



Imperator

Fortress

Spartan

Get years of reliable service from a quality transformer at a practical price

HPS Imperator™ control transformers for industrial applications

HPS Imperator control transformers from Hammond are designed for high inrush applications requiring reliable output voltage stability. Designed for industrial applications where electromagnetic devices such as relays, solenoids, etc. are used, they maximize inrush capability and output voltage regulation when electromagnetic devices are initially energized.

HPS Imperator control transformers use Mylar, Nomex and other high-quality insulating materials to electrically insulate turn-to-turn windings, layer-to-layer windings, primary-to-secondary windings and ground. These transformers are vacuum impregnated with VT polyester resin and oven-cured, which seals the surface and eliminates moisture. Filling the entire unit provides a strong mechanical bond and offers protection from the environment. This design utilizes superior insulation systems and is constructed with high quality silicon steel laminations, which provide optimum performance and reliability.

The custom injection-molded cover, with its unique fin-shaped design, provides excellent cooling properties while protecting the coils and terminations from moisture, dirt and other industrial airborne contaminants.

The heavy steel mounting feet are welded to the core, providing maximum strength and low noise in a compact design.

The HPS Imperator's unique terminal block design (patent pending) allows for the quick and easy installation of standard secondary or optional primary 13/32 x 1 1/2in midget/type CC fuse clips on every unit. This is the simplest and most inexpensive fusing installation provided on any industrial control transformer in the market today.

The windings and internal terminations of the HPS Imperator are encapsulated, which protects them from moisture, dirt and other airborne contaminants. The custom molded coil covers with their unique fin-shaped design combine superior transformer cooling properties with a clean bold look.

The HPS Imperator utilizes custom serrated terminals in combination with standard SEMS washer screws for easier assembly and quicker installation as well as superior connection strength when connecting with bare, solid, or stranded wire. It also allows for ring or spade termination connectors with a maximum width of 0.37in (9.4mm).

HPS Fortress™ commercial potted transformers

The HPS Fortress commercial potted transformers provide an innovative design with commercial applications where quality, ease of installation, and low cost are key.

All Fortress units are encapsulated with electrical grade silica sand and resin compounds, which completely enclose the core and coil to seal out moisture, airborne contaminants and eliminates corrosion and deterioration.

HPS Spartan™ open core and coil control transformers

The HPS Spartan line of industrial open-style control transformers is ideally suited for general purpose, industrial and light duty loads.

Designed for applications with lower inrush and where less demanding environmental protections are needed, HPS Spartan models offer an efficient and economical solution. They feature molded terminal blocks up to 3000 VA or 30A. Optional finger guards and a fuse block adapter kit are available.

Superior quality and value

- Compact, efficient design
- Easy installation and hook-up
- Inexpensive while maintaining superior quality in materials and workmanship
- Wall mounting

Applications

- Lighting
- Motor control circuits
- HVAC
- Signal and alarm systems
- Circuit isolation
- Schools
- Office buildings

HPS Imperator™ Control Transformer Selection



To select the proper transformer, you must first determine three characteristics of the load circuit. They are: total steady-state (sealed) VA, total inrush VA, and inrush load power factor.

Total steady-state “sealed” VA is the total amount of VA that the transformer must supply to the load circuit for an extended length of time. Calculate by adding the total steady-state VA of all devices in your control circuit. (The operating VA data for the devices should be available from the manufacturers.)

The inrush VA is the amount of VA that the transformer must supply for all components in the control circuit that are energized together. Consideration for the start-up sequence may be required. (Inrush VA data should be obtained from the device manufacturers.)

The inrush load power factor is difficult to determine without detailed vector analysis of all the control components. In the absence of such information, we recommend that a 40% power factor be utilized.

Six easy steps

Once the three load circuit variables have been determined, follow these steps to select the proper transformer.

1. Determine your primary (supply) and secondary (output) voltage requirements, as well as the required frequency (i.e. 60 Hz).
2. Calculate the total sealed VA of your circuit by adding the total sealed VA of all devices in the control circuit.
3. Calculate the inrush VA by adding the inrush VA of all components being energized together. Remember to add the sealed VA of all components that do not have inrush VA (lamps, timers, etc.), as they do present a load to the transformer during maximum inrush. If the inrush for your components is unknown, assume a 40% inrush power factor.
4. Calculate the total inrush VA using one of two methods as shown below. **Method B will result in selection of a slightly larger transformer.**

A
$$\text{Total Inrush VA} = \sqrt{(\text{VA sealed})^2 + (\text{VA inrush})^2}$$

or

B
$$\text{Total Inrush VA} = \text{VA Sealed} + \text{VA Inrush}$$

5. If the nominal supply voltage does not fluctuate more than 5%, reference the 90% secondary voltage column in the Regulation Data Table for the correct VA rating.

If the supply voltage varies up to 10%, the 95% secondary voltage column should be used to size the transformer. The 85% secondary voltage column gives minimum values for proper electromagnetic device operation and should only be used as a reference.

HPS Imperator Transformer Regulation Data Table

Continuous VA Transformer Nameplate	Inrush VA @ 40% Power Factor		
	85% Secondary Voltage	90% Secondary Voltage	95% Secondary Voltage
50	330	259	192
75	350	258	170
100	620	467	321
150	895	699	512
250	1596	1229	880
350	2464	1889	1345
500	3939	2854	1819
750	6422	4778	3228
1000	9842	7102	4530
1500	12797	9018	5489

Note: It is recommended that a control transformer be sized at a 40% power factor. Some components in a circuit, such as electromagnetic devices, typically operate at that level due to their inherently lower power factor. Selecting a transformer at 40% power factor will more than adequately size the unit for all the various loads in the circuit.

6. Using the regulation data table below, select the appropriate VA rated transformer:
 - A. With a continuous VA rating that is equal to or greater than the value in Step 2.
 - B. With a maximum inrush VA equal to or greater than the value obtained in Step 4.

Note: See over-current protection chart for transformers at the end of this section.

Voltage regulation in transformers

Voltage regulation in transformers is the difference between the “No-Load voltage” and the “Full-Load voltage.” This is expressed in terms of percentage.

$$\text{Regulation Percentage} = \frac{E_{\text{No-Load}} - E_{\text{Full Load}}}{E_{\text{Full Load}}} (100\%)$$

The secondary voltages (nominal) listed in these pages are at Full-Load, meaning the point at which the transformer is operating at maximum permissible secondary current. No-Load voltage can increase 4 to 6%.

Warning:

Secondary voltages of transformers may damage some loads. For example, a transformer connected as 480/120V but applied 495V primary can produce at No-Load a voltage of 134V which will damage the inputs of a PLC [D0-06AA](#), whose maximum input voltage is 132V. Notice that the current of [D0-06AA](#) input is 10 mA, making it very close to No-Load.

HPS Imperator™ 240x120 / 24x12 VAC Control Transformers



Features

- 600V class, machine tool rated industrial control transformers
- 50/60 Hz
- VA range from 50 VA up to 1000 VA
- Constructed with high-quality silicon steel laminations that provide optimum performance and reliability
- Encapsulated coils encased in a custom injection molded cover which protects coils and terminations from moisture, dirt and other industrial airborne contaminants
- Temperature range: -20 °C [-4 °F] to 40 °C [104 °F]
- Terminated with #8-32 slot/Phillips terminal screws complete with SEMS washer (suitable for 18 AWG to 14 AWG solid or 14 AWG stranded wire, not on PH750PG or PH1000PG). A ring or spade connector (maximum width 0.37in [9.4mm]) must be used on larger size wire.
- Insulation system:
 - 50–150 VA: Temperature rise 55 °C [131 °F], insulation class 105 °C [221 °F]
 - 250–1000 VA: Temperature rise 80 °C [176 °F], insulation class 130 °C [266 °F]
- Standard secondary fuse kits utilizing 13/32 x 1.5in CC fuse clips included with all transformers. Fuses are not included (see Edison fuse section for MEN fuses).
- Optional primary fuse kits available utilizing 13/32 x 1.5in fuse clips (See Edison HCTR series fuses at automationdirect.com)
- Optional finger-safe terminal covers
- LIFETIME warranty (limited to manufacturing defects)

Agency Approvals

- UL Listed (approved for U.S. and Canada) File E50394
- CE Mark standard on all units



HPS Imperator 240x120 / 24x12 Control Transformer Specifications

Part Number	Price	Volt-Amp Rating*	Mtg. Fig.	Primary Voltage (VAC) (50/60 Hz)	Secondary Voltage (VAC) (Nominal)	Output Current (Amps) 12/24 VAC	Impedance %		Total Heat Dissipation (Watts)**	Weight (lb [kg])
							VA	%z		
PH50PG		50	A	120x240 115x230 110x220	12x24 11.5x23 11x22	4.17/2.08	50	8.3	11	3.5 [1.59]
PH75PG		75	A			6.25/3.13	75	8.7	14	3.5 [1.59]
PH100PG		100	A			8.33/4.17	100	8.4	14	4.5 [2.04]
PH150PG		150	B			12.5/6.25	150	8.0	18	5.7 [2.59]
PH250PG		250	B			20.8/10.4	250	7.8	29	7.5 [3.40]
PH350PG		350	B			29.2/14.6	350	7.0	33	10.1 [4.58]
PH500PG		500	B			41.7/20.8	500	5.0	40	14.2 [6.44]
PH750PG***		750	B			62.5/31.3	750	4.9	54	16.6 [7.53]
PH1000PG***		1000	B			83.3/41.7	1000	3.9	69	23.6 [10.70]

Note: *VA capacity rated at the output of the transformer.

** Heat dissipation calculated based on full rated load on transformer.

*** Terminated with 1/4-20 screw on secondary side to accept ring terminal connector

Dimensions

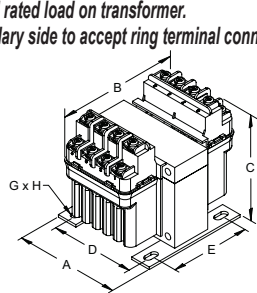

(100 VA and less)

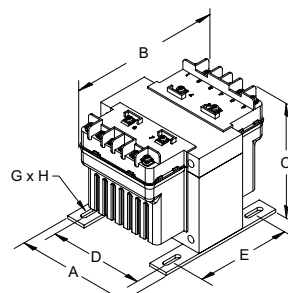

(150 VA to 1000 VA)

HPS Imperator 240x120 / 24x12 Control Transformer Dimensions

Part Number	Mtg. Fig.	Overall Dimensions (in [mm])			Mounting Centers (in [mm])		Mounting Slot (in [mm])	Height with Finger Guard (in [mm])	Depth with Finger Guard (in [mm])
		A	B	C	D	E	G X H		
PH50PG	A	3.00 [76.2]	4.38 [111.3]	3.19 [81.0]	2.50 [63.5]	2.25 [57.2]	0.22 x 0.44 [5.6 x 11.2]	4.00 [101.6]	5.82 [147.8]
PH75PG	A	3.25 [82.6]	3.88 [85.9]	3.56 [90.4]	2.63 [66.8]	2.50 [63.5]	0.22 x 0.44 [5.6 x 11.2]	4.37 [111.0]	5.32 [135.1]
PH100PG	A	3.25 [82.6]	4.19 [106.4]	3.63 [92.2]	2.63 [66.8]	2.63 [66.8]	0.22 x 0.44 [5.6 x 11.2]	4.44 [112.8]	5.63 [143.0]
PH150PG	B	4.00 [101.6]	4.94 [125.5]	3.81 [96.8]	3.38 [85.9]	2.75 [69.9]	0.22 x 0.75 [5.6 x 19.1]	4.31 [109.5]	6.44 [163.6]
PH250PG	B	4.50 [114.3]	5.44 [138.2]	3.81 [96.8]	3.75 [95.3]	3.13 [79.5]	0.22 x 0.75 [5.6 x 19.1]	4.31 [109.5]	6.94 [176.3]
PH350PG	B	4.50 [114.3]	5.19 [131.8]	4.44 [112.8]	3.75 [95.3]	3.75 [95.3]	0.22 x 0.75 [5.6 x 19.1]	4.94 [125.5]	6.69 [169.9]
PH500PG	B	4.75 [120.7]	5.94 [150.9]	4.31 [109.5]	4.06 [103.1]	3.81 [96.8]	0.31 x 0.94 [7.9 x 23.9]	4.81 [122.2]	7.44 [189.0]
PH750PG	B	5.13 [130.3]	6.69 [169.9]	4.31 [109.5]	4.38 [111.3]	4.31 [109.5]	0.31 x 0.81 [7.9 x 20.6]	4.81 [122.2]	8.19 [208.1]
PH1000PG	B	5.25 [133.4]	6.81 [173.0]	4.94 [125.5]	4.50 [114.3]	4.44 [112.8]	0.31 x 0.81 [7.9 x 20.6]	5.44 [138.2]	8.31 [211.1]

Note: All dimensions are ±0.06in unless otherwise noted.

HPS Imperator™ 240x120 / 24x12 VAC Control Transformers



Wiring

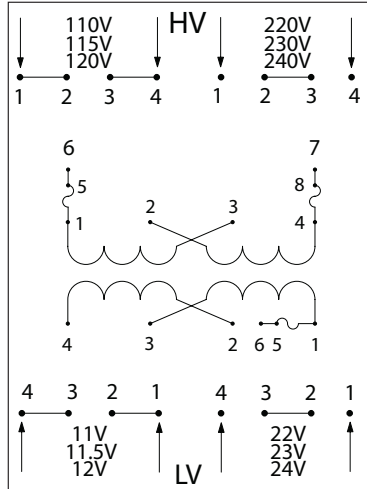

PH***PG Schematic for 50, 75 and 100VA Units

High Voltage (HV) (Primary Volts)	Install Supplied Links Between Terminals	Supply Lines Connect To	Install Fuse Clips To
120 115 110	1-2, 3-4	1, 4	Unfused
240 230 220	2-3	1, 4	Unfused
120 115 110	1-2, 3-4	6, 7	1-5, 4-8
240 230 220	2-3	6, 7	1-5, 4-8

Low Voltage (LV) (Secondary Volts)	Install Supplied Links Between Terminals	Load Lines Connect To	Install Fuse Clips To
12 11.5 11	3-4, 1-2	1, 4	Unfused
24 23 22	2-3	1, 4	Unfused
12 11.5 11	3-4, 1-2	4, 6	1-5
24 23 22	2-3	4, 6	1-5

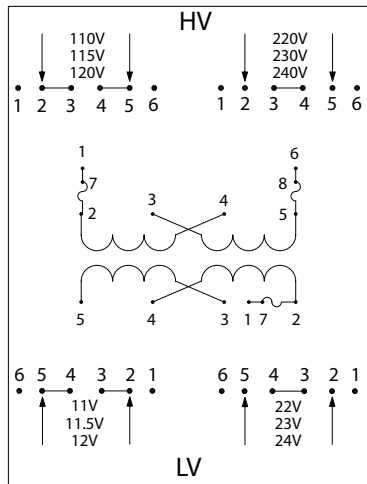

PH***PG Schematic for 150VA to 500VA Units

High Voltage (HV) (Primary Volts)	Install Supplied Links Between Terminals	Supply Lines Connect To	Install Fuse Clips To
120 115 110	2-3, 4-5	2, 5	Unfused
240 230 220	3-4	2, 5	Unfused
120 115 110	2-3, 4-5	1, 6	2-7, 5-8
240 230 220	3-4	1, 6	2-7, 5-8

Low Voltage (LV) (Secondary Volts)	Install Supplied Links Between Terminals	Load Lines Connect To	Install Fuse Clips To
12 11.5 11	4-5, 2-3	2, 5	Unfused
24 23 22	3-4	2, 5	Unfused
12 11.5 11	4-5, 2-3	1, 5	2-7
24 23 22	3-4	1, 5	2-7

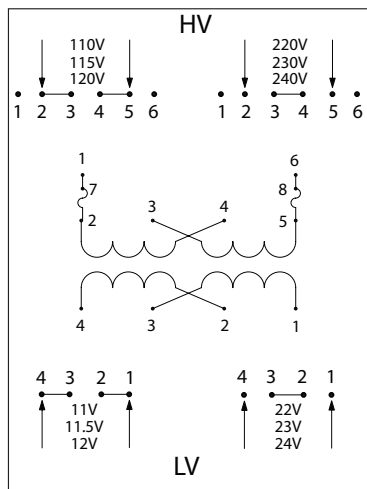

PH***PG Schematic for 750VA and 1000VA Units

High Voltage (HV) (Primary Volts)	Install Supplied Links Between Terminals	Supply Lines Connect To	Install Fuse Clips To
120 115 110	2-3, 4-5	2, 5	Unfused
240 230 220	3-4	2, 5	Unfused
120 115 110	2-3, 4-5	1, 6	2-7, 5-8
240 230 220	3-4	1, 6	2-7, 5-8

Low Voltage (LV) (Secondary Volts)	Install Supplied Links Between Terminals	Load Lines Connect To	Install Fuse Clips To
12 11.5 11	3-4, 1-2	1, 4	Unfused
24 23 22	2-3	1, 4	Unfused

Note: secondary fuse clips not available on PH750PG or PH1000PG.

Notes

- FUSES NOT INCLUDED (see Edison HCTR series fuses at automationdirect.com).
- Jumper links to make primary/secondary series/parallel connections supplied, but not installed.
- Secondary fuse clips supplied but not installed. Order fuses and primary fuse clips separately.

HPS Imperator™ Transformers Accessories— Terminal Covers and Fuse Kits



Finger-safe terminal covers

These one-piece molded terminal covers are a quick and easy way to provide safety and protection in the workplace. They protect operators from potential shock hazards and guard against accidental contact with the fuses.

Fuse Kits

These optional primary side fuse kits contain four fuse clips, four mounting screws, and complete instructions. The table below makes it easy to choose the correct terminal covers and fuse kits for your Hammond control transformer.

Transformer		Finger-Safe Terminal Covers			Primary Side Fuse Kits		
Part Number	Part #	Pcs/Pkg	Price	Description	Part #	Pcs/Pkg	Price
PH50MQMJ PH50PG	FG1	1 cover		Finger-safe cover for MQMJ and PG series 50 VA unfused control transformers. Cover fits primary side or secondary side.	PFK1	4 fuse clips, 4 mounting screws	
	FGF1	1 cover		Finger-safe cover for MQMJ and PG series 50 VA fused control transformers. Cover fits primary side or secondary side.			
PH75MQMJ PH75PG PH100MQMJ PH100PG	FG2	1 cover		Finger-safe cover for all 75 VA, all 100 VA, PH50MLI and PH50MGJ unfused control transformers. Cover fits primary or secondary side.	PFK2	4 fuse clips, 4 mounting screws	
	FGF2	1 cover		Finger-safe cover for 75 VA, all 100 VA, PH50MLI and PH50MGJ fused control transformers. Cover fits primary or secondary side.			
PH150MQMJ PH150PG PH250MQMJ PH250PG	FG3	1 cover		Finger-safe cover for all 150 VA, PH250MQMJ and PH250PG fused and unfused control transformers. Cover fits primary or secondary side.	PFK2	4 fuse clips, 4 mounting screws	
PH350MQMJ PH350PG PH500MQMJ PH500PG PH750MQMJ	FG4	1 cover		Finger-safe cover for all 350 VA, 500 VA, PH250MLI, PH250MGJ, and PH750MQMJ fused and unfused control transformers. Cover fits primary or secondary side.	PFK3	4 fuse clips, 4 mounting screws	
PH1000MQMJ PH750PG PH1500MQMJ PH1000PG	FG5	1 cover		Finger-safe cover for all 750 VA, 1000 VA, 1500 VA fused and unfused control transformers. Cover fits primary or secondary side.			
PH50MLI PH50MGJ	FG2	1 cover		Finger-safe cover for all 75 VA, all 100 VA, PH50MLI and PH50MGJ unfused control transformers. Cover fits primary or secondary side.	PFK4	4 fuse clips, 4 mounting screws 1 cover 1 jumper wire	
	FGF2	1 cover		Finger-safe cover for 75 VA, all 100 VA, PH50MLI and PH50MGJ fused control transformers. Cover fits primary or secondary side.			
PH100MLI PH75MGJ PH100MGJ	FG2	1 cover		Finger-safe cover for all 75 VA, all 100 VA, PH50MLI and PH50MGJ unfused control transformers. Cover fits primary or secondary side.	PFK5	4 fuse clips, 4 mounting screws 1 cover 1 jumper wire	
	FGF2	1 cover		Finger-safe cover for 75 VA, all 100 VA, PH50MLI and PH50MGJ fused control transformers. Cover fits primary or secondary side.			
PH150MGJ PH150MLI	FG3	1 cover		Finger-safe cover for all 150 VA, PH250MQMJ and PH250PG fused and unfused control transformers. Cover fits primary or secondary side.	PFK6	4 fuse clips, 4 mounting screws 1 jumper wire	
PH250MLI PH250MGJ	FG4	1 cover		Finger-safe cover for all 350 VA, 500 VA, PH250MLI, PH250MGJ, and PH750MQMJ fused and unfused control transformers. Cover fits primary or secondary side.	PFK6	4 fuse clips, 4 mounting screws 1 jumper wire	
PH350MLI PH350MGJ PH500MLI PH500MGJ				Finger-safe cover for all 350 VA, 500 VA, PH250MLI, PH250MGJ, and PH750MQMJ fused and unfused control transformers. Cover fits primary or secondary side.			
PH750MLI PH1000MLI PH1000MGJ	FG5	1 cover		Finger-safe cover for all 1000VA, 1500VA, PH750PG, and PH750MLI fused and unfused control transformers. Cover fits primary or secondary side.	PFK7	4 fuse clips, 4 mounting screws 1 jumper wire	

1. Torque all terminal screws between 12 and 14 lb•in (1.36 and 1.58 N•m)
2. For all bare wire connections, the recommended wire size range is 18 AWG to 14 AWG for solid wire and 14 AWG for stranded. A ring or spade connector (maximum width 0.37in [9.4mm]) must be used if using a wire size outside the range listed above.
3. Ensure mounting screws used for transformer installation (not supplied) are properly sized for transformer weight.
4. When mounting fuse clips, remove the appropriate captive washer screw(s) from terminal block and install fuse clip(s) and new terminal screw(s).
5. Please refer to wiring instructions included with the Hammond control transformer for connection details.

Finger-safe Cover accessories

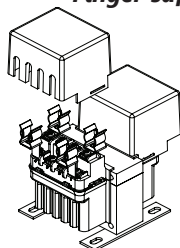

Sample Assembly Drawing for Finger Guard Installation (for 50, 75 and 100 VA)

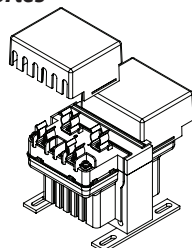

Sample Assembly Drawing for Finger Guard Installation (for 150 VA to 1500 VA)

Fuse Clips accessories

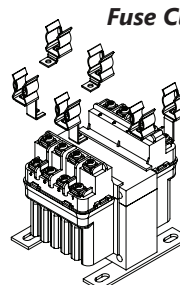

Sample Assembly Drawing for Fuse Clip Installation (for 50, 75 and 100 VA)

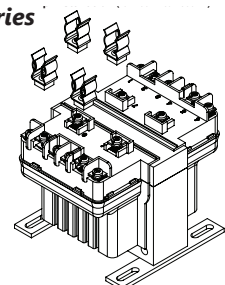

Sample Assembly Drawing for Fuse Clip Installation (for 150 VA to 1500 VA)

Standard secondary fuse kits utilizing 13/32in x 1 1/2in fuse clips included with all transformers. Fuses are not included. (See Edison fuse section for MEN fuses.)