

# Hammond Transformers



Imperator

Fortress

Spartan

Get years of reliable service from a quality transformer at a practical price

## HPS Imperator™ control transformers for industrial applications

HPS Imperator control transformers from Hammond are designed for high inrush applications requiring reliable output voltage stability. Designed for industrial applications where electromagnetic devices such as relays, solenoids, etc. are used, they maximize inrush capability and output voltage regulation when electromagnetic devices are initially energized.

HPS Imperator control transformers use Mylar, Nomex and other high-quality insulating materials to electrically insulate turn-to-turn windings, layer-to-layer windings, primary-to-secondary windings and ground. These transformers are vacuum impregnated with VT polyester resin and oven-cured, which seals the surface and eliminates moisture. Filling the entire unit provides a strong mechanical bond and offers protection from the environment. This design utilizes superior insulation systems and is constructed with high quality silicon steel laminations, which provide optimum performance and reliability.

The custom injection-molded cover, with its unique fin-shaped design, provides excellent cooling properties while protecting the coils and terminations from moisture, dirt and other industrial airborne contaminants.

The heavy steel mounting feet are welded to the core, providing maximum strength and low noise in a compact design.

The HPS Imperator's unique terminal block design (patent pending) allows for the quick and easy installation of standard secondary or optional primary 13/32 x 1 1/2in midget/type CC fuse clips on every unit. This is the simplest and most inexpensive fusing installation provided on any industrial control transformer in the market today.

The windings and internal terminations of the HPS Imperator are encapsulated, which protects them from moisture, dirt and other airborne contaminants. The custom molded coil covers with their unique fin-shaped design combine superior transformer cooling properties with a clean bold look.

The HPS Imperator utilizes custom serrated terminals in combination with standard SEMS washer screws for easier assembly and quicker installation as well as superior connection strength when connecting with bare, solid, or stranded wire. It also allows for ring or spade termination connectors with a maximum width of 0.37in (9.4mm).

## HPS Fortress™ commercial potted transformers

The HPS Fortress commercial potted transformers provide an innovative design with commercial applications where quality, ease of installation, and low cost are key.

All Fortress units are encapsulated with electrical grade silica sand and resin compounds, which completely enclose the core and coil to seal out moisture, airborne contaminants and eliminates corrosion and deterioration.

## HPS Spartan™ open core and coil control transformers

The HPS Spartan line of industrial open-style control transformers is ideally suited for general purpose, industrial and light duty loads.

Designed for applications with lower inrush and where less demanding environmental protections are needed, HPS Spartan models offer an efficient and economical solution. They feature molded terminal blocks up to 3000 VA or 30A. Optional finger guards and a fuse block adapter kit are available.

## Superior quality and value

- Compact, efficient design
- Easy installation and hook-up
- Inexpensive while maintaining superior quality in materials and workmanship
- Wall mounting

## Applications

- Lighting
- Motor control circuits
- HVAC
- Signal and alarm systems
- Circuit isolation
- Schools
- Office buildings

# HPS Spartan™ Open Core and Coil Control Transformer Selection



## Control transformer selection

To select the proper transformer, you must first determine three characteristics of the load circuit. They are: total steady-state (sealed) VA, total inrush VA, and inrush load power factor.

Total steady-state “sealed” VA is the total amount of VA that the transformer must supply to the load circuit for an extended length of time. Calculate by adding the total steady-state VA of all devices in your control circuit. (*The operating VA data for the devices should be available from the manufacturers.*)

The inrush VA is the amount of VA that the transformer must supply for all components in the control circuit that are energized together. Consideration for the start-up sequence may be required. (*Inrush VA data should be obtained from the device manufacturers.*)

The inrush load power factor is difficult to determine without detailed vector analysis of all the control components. In the absence of such information, we recommend that a 40% power factor be utilized.

## Six easy steps

Once the three load circuit variables have been determined, follow these steps to select the proper transformer.

1. Determine your primary (supply) and secondary (output) voltage requirements, as well as the required frequency (i.e. 60 Hz).
2. Calculate the total sealed VA of your circuit by adding the total sealed VA of all devices in the control circuit.
3. Calculate the inrush VA by adding the inrush VA of all components being energized together. Remember to add the sealed VA of all components that do not have inrush VA (lamps, timers, etc.), as they do present a load to the transformer during maximum inrush. If the inrush for your components is unknown, assume a 40% inrush power factor.
4. Calculate the total inrush VA using one of two methods as shown below. **Method B will result in selection of a slightly larger transformer.**
5. If the nominal supply voltage does not fluctuate more than 5%, reference the 90% secondary voltage column in the Regulation Data Table for the correct VA rating.

If the supply voltage varies up to 10%, the 95% secondary voltage column should be used to size the transformer. The 85% secondary voltage column gives minimum values for proper

**A** 
$$\text{Total Inrush VA} = \sqrt{(\text{VA sealed})^2 + (\text{VA inrush})^2}$$

or

**B** 
$$\text{Total Inrush VA} = \text{VA Sealed} + \text{VA Inrush}$$

HPS Spartan Transformer Regulation Data Table			
Continuous VA Transformer Nameplate	Inrush VA @ 40% Power Factor		
	85% Secondary Voltage	90% Secondary Voltage	95% Secondary Voltage
50	177	139	102
100	350	275	203
150	715	554	400
250	1653	1264	895
350	2604	1947	1321
500	4004	3023	2090
750	6933	5088	3352
1000	10087	7340	4764
1500	14178	10232	6508
2000	17604	12669	8080
3000	39213	27539	16780
5000	68344	47498	28803

*Note: It is recommended that a control transformer be sized at a 40% power factor. Some components in a circuit, such as electromagnetic devices, typically operate at that level due to their inherently lower power factor. Selecting a transformer at 40% power factor will more than adequately size the unit for all the various loads in the circuit.*

electromagnetic device operation and should only be used as a reference.

6. Using the regulation data table below, select the appropriate VA rated transformer:
  - A. With a continuous VA rating that is equal to or greater than the value in Step 2.
  - B. With a maximum inrush VA equal to or greater than the value obtained in Step 4.

*Note: See over-current protection chart for transformers at the end of this section.*

## Voltage regulation in transformers

Voltage regulation in transformers is the difference between the “No-Load voltage” and the “Full-Load voltage.” This is expressed in terms of percentage. The secondary voltages (nominal) listed in these pages are at Full-Load, meaning the point at which the transformer is operating at maximum permissible secondary current. No-Load voltage can increase 4 to 6%.

$$\text{Regulation Percentage} = \frac{E_{\text{No-Load}} - E_{\text{Full Load}}}{E_{\text{Full Load}}} (100\%)$$

### Warning:

Secondary voltages of transformers may damage some loads. For example, a transformer connected as 480/120V but applied 495V primary can produce at No-Load a voltage of 134V which will damage the inputs of a PLC [D0-06AA](#), whose maximum input voltage is 132V. Notice that the current of [D0-06AA](#) input is 10 mA, making it very close to No-Load.

# HPS Spartan™ 240x480 / 120x240 VAC



## Open Core and Coil Control Transformers

### Features

- Multi-voltage primary and secondary models increase range of application per unit
- Standard molded terminal blocks or primary and secondary up to 3000 VA (30A) units
- Solid terminal block with standard combination screw connection
- 50/60 Hz
- Copper-wound coils with high dielectric strength insulation
- Bolted core construction
- Bolt-on mounting brackets
- Vacuum impregnated with polyester resin and oven cured
- Seismically certified in accordance with IBC 2009; Section 1613 Earthquake Loads, for SDS ≤ 2.00g, z/h = 1.0, and IP = 1.5
- Superior insulating materials. The HPS Spartan series transformers offer the following insulation systems:
  - 130 °C [80°C rise] up to 1500 VA
  - 180 °C [115°C rise] 2000 VA to 5000 VA
  - Temperature range: -20 °C [-4 °F] to 40 °C [104 °F]
- All terminal blocks utilize a combination slot/Phillips #6-32 screw with a SEMS washer (suitable for 18 AWG to 14 AWG for solid wire and 18 AWG to 12 AWG for stranded wire). Coil face terminations utilize a ¼-20 UNC X 0.50in combination slot/Phillips screw and a spring lock washer.
- All units supplied with primary and secondary voltage links/jumpers
- Optional finger guards available, up to and including 3000 VA or 30A
- Optional fuse block adapter kit available, up to and including 3000 VA or 30A
- Supplied with trilingual installation and wiring instruction sheets
- **15 year warranty**

### Agency Approvals

- UL Listed (approved for U.S. and Canada) File E50394 (Models/Type 3AH)
- CE Mark standard on all units
- CSA LR3902
- RoHS Compliant



### HPS Spartan 240x480 / 120x240 Open Core and Coil Control Transformer Specifications

Part Number	Price	Volt-Amp Rating	CE Volt-Amp	Mtg. Fig.	Primary Voltage (VAC) (50/60 Hz)	Secondary Voltage (VAC) (Nominal)	Output Current (Amps) 120/240 VAC	Impedance %		Total Heat Dissipation (Watts)**	Weight lb [kg]
								VA	%z		
<a href="#">SP50MQMJ</a>		50	50	A	240x480 230x460 220x440	120x240 115x230 110x220	0.42/0.21	50	8.3	14	1.7 [0.77]
<a href="#">SP100MQMJ</a>		100	100	A			0.83/0.42	100	6.9	24	3 [1.36]
<a href="#">SP150MQMJ</a>		150	150	A			1.25/0.63	150	8.4	29	4.3 [1.95]
<a href="#">SP250MQMJ</a>		250	160	A			2.08/1.04	250	7.8	40	6.5 [2.95]
<a href="#">SP350MQMJ</a>		350	250	A			2.92/1.46	350	7.0	48	8.2 [3.72]
<a href="#">SP500MQMJ</a>		500	300	A			4.17/2.08	500	5.0	61	11 [4.99]
<a href="#">SP750MQMJ</a>		750	500	A			6.25/3.13	750	4.9	75	16 [7.26]
<a href="#">SP1000MQMJ</a>		1000	650	A			8.33/4.17	1000	3.7	90	21 [9.53]
<a href="#">SP1500MQMJ</a>		1500	1000	A			12.5/6.25	1500	3.9	122	28 [12.70]
<a href="#">SP2000MQMJ</a>		2000	1300	A			16.7/8.33	2000	4.0	194	35 [15.88]
<a href="#">SP3000MQMJ</a>		3000	2000	A			25.0/12.5	3000	2.5	206	64 [29.03]
<a href="#">SP5000MQMJ</a>		5000	3000	B			41.7/20.8	5000	2.5	319	97 [44.00]

Note: \*VA capacity rated at the output of the transformer.

\*\* Heat dissipation calculated based on full rated load on transformer.

Note: The impedance values listed in the table above are calculated typical values only. Actual measured impedance values may vary based on a specific design.

# HPS Spartan™

## 240x480 / 120x240 VAC

### Open Core and Coil Control Transformers



## Dimensions

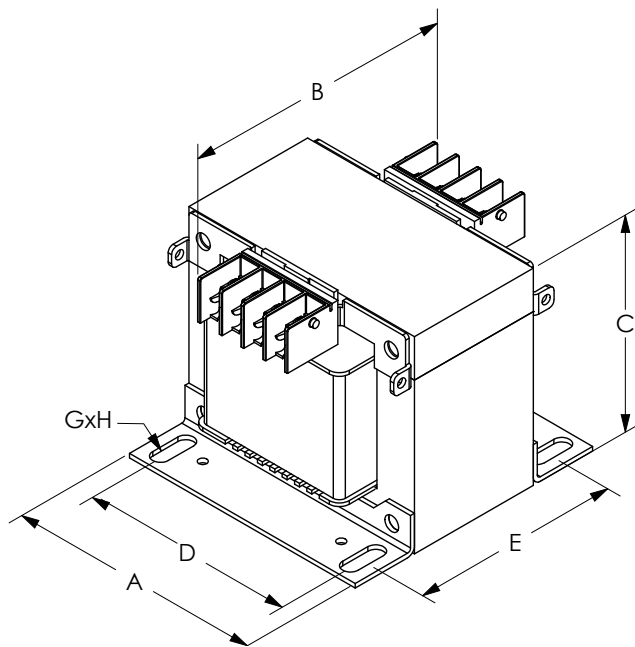

Figure A

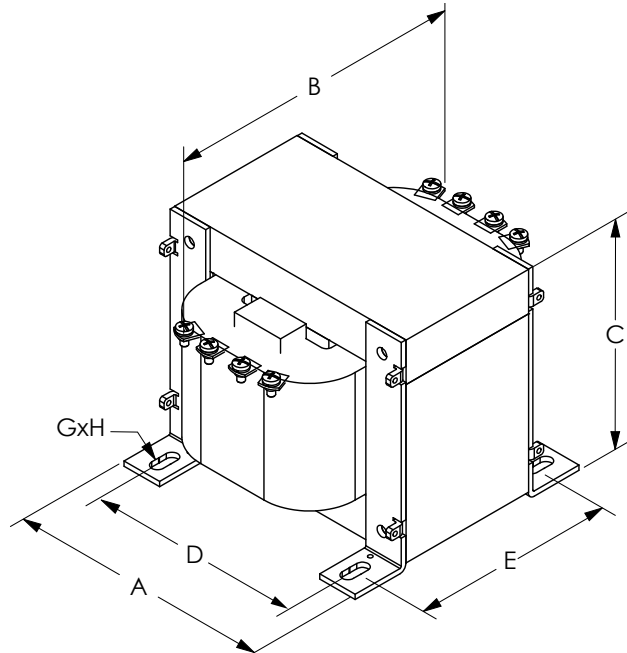

Figure B

### HPS Spartan 240x480 / 120x240 Open Core and Coil Control Transformer Dimensions

Part Number	Mtg. Fig.	Overall Dimensions (in [mm])			Mounting Centers (in [mm])		Mounting Slot (in [mm])	Height with Finger Guard (in [mm])	Height with Fuse Block Adapter (in [mm])
		A	B	C	D	E	G X H		
<a href="#">SP50MQMJ</a>	A	2.60 [66.04]	3.35 [85.09]	2.60 [66.04]	2.13 [54.10]	2.17 [55.12]	0.22 x 0.44 [5.59x11.18]	2.98 [75.69]	2.79 [70.87]
<a href="#">SP100MQMJ</a>	A	2.99 [75.95]	3.74 [95.00]	2.85 [72.39]	2.52 [64.01]	2.60 [66.04]	0.22 x 0.44 [5.59x11.18]	3.23 [82.04]	3.04 [77.22]
<a href="#">SP150MQMJ</a>	A	2.99 [75.95]	4.29 [108.97]	2.85 [72.39]	2.52 [64.01]	3.15 [80.01]	0.22 x 0.44 [5.59x11.18]	3.23 [82.04]	3.04 [77.22]
<a href="#">SP250MQMJ</a>	A	3.78 [96.01]	4.09 [103.89]	3.40 [86.36]	3.31 [84.07]	2.99 [75.95]	0.22 x 0.44 [5.59x11.18]	3.78 [96.01]	3.59 [91.19]
<a href="#">SP350MQMJ</a>	A	3.78 [96.01]	4.69 [119.13]	3.40 [86.36]	3.31 [84.07]	3.58 [90.93]	0.22 x 0.44 [5.59x11.18]	3.78 [96.01]	3.59 [91.19]
<a href="#">SP500MQMJ</a>	A	4.49 [114.05]	4.69 [119.13]	3.78 [96.01]	3.78 [96.01]	3.66 [92.96]	0.31 x 0.81 [7.87x20.57]	4.16 [105.66]	3.97 [100.84]
<a href="#">SP750MQMJ</a>	A	5.25 [133.35]	4.69 [119.13] <sup>1</sup>	4.37 [111.00]	4.50 [114.30]	3.66 [92.96]	0.31 x 0.81 [7.87x20.57]	4.75 [120.65]	4.56 [115.82]
<a href="#">SP1000MQMJ</a>	A	5.25 [133.35]	5.47 [138.94] <sup>1</sup>	4.37 [111.00]	4.50 [114.30]	4.45 [113.03]	0.31 x 0.81 [7.87x20.57]	4.75 [120.65]	4.56 [115.82]
<a href="#">SP1500MQMJ</a>	A	5.25 [133.35]	6.85 [173.99] <sup>1</sup>	4.37 [111.00]	4.50 [114.30]	5.83 [148.08]	0.31 x 0.81 [7.87x20.57]	4.75 [120.65]	4.56 [115.82]
<a href="#">SP2000MQMJ</a>	A	6.38 [162.05]	5.87 [149.10] <sup>1</sup>	5.31 [134.87]	5.75 [146.05]	4.84 [122.94]	0.31 x 0.81 [7.87x20.57]	5.50 [139.70]	5.31 [134.87]
<a href="#">SP3000MQMJ</a>	A	7.50 [190.50]	7.50 [190.50]	6.50 [165.10]	6.30 [160.02]	7.28 [184.91]	0.44 x 1.00 [11.18x25.4]	6.50 [165.10]	6.50 [165.10]
<a href="#">SP5000MQMJ</a>	B	8.98 [228.09]	9.88 [250.95]	7.76 [197.10]	7.40 [187.96]	7.28 [184.91]	0.44 x 1.00 [11.18x25.4]	N/A	N/A

Note: All dimensions are ±0.06in unless otherwise noted.

1: For 750 through 2000 VA units actual overall depth is 0.24in plus the value in column B.

# HPS Spartan™

## 240x480 / 120x240 VAC

### Open Core and Coil Control Transformers



## Wiring

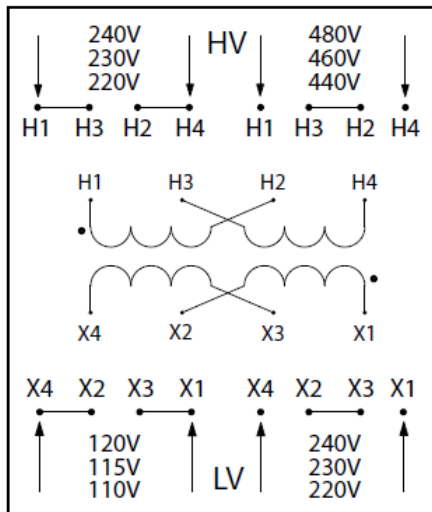

### SP\*\*\*MQMJ Schematic Connections for 240 X 480 to 120 X 240

#### High Voltage (HV) (Primary Volts)

240	230	220
480	460	440

#### Install Supplied Jumpers Between Terminals

H1-H3, H2-H4
H2-H3

#### Supply Lines Connect To

H1, H4
H1, H4

#### Low Voltage (LV) (Secondary Volts)

120	115	110
240	230	220

#### Install Supplied Links Between Terminals

X1-X3, X2-X4
X2-X3

#### Load Lines Connect To

X1, X4
X1, X4

# HPS Spartan™

## Transformers Accessories – Fuse Block Adapter Kit and Finger Guards



### Fuse Block Adapter Kit

HPS Spartan industrial control transformers up to and including 3000 VA or 30A are available with optional fuse block adapter kits. The Fuse block Adapter Kit is designed to allow for the installation of any third-party or aftermarket fuse block assembly onto the industrial control transformer. The transformer must be a unit that incorporates a molded terminal block on either the primary or secondary side.

No jumpers or appropriate fuses are provided for any aftermarket fuse block you install on an HPS Spartan industrial control transformer.

Note that the HPS Fuse Block Adapter Kit provides only the mechanical means of attaching a third-party aftermarket fuse block.

The Fuse Block Adapter Kit is not available on [SP5000ACP](#) and [SP5000MQMJ](#) standard units.

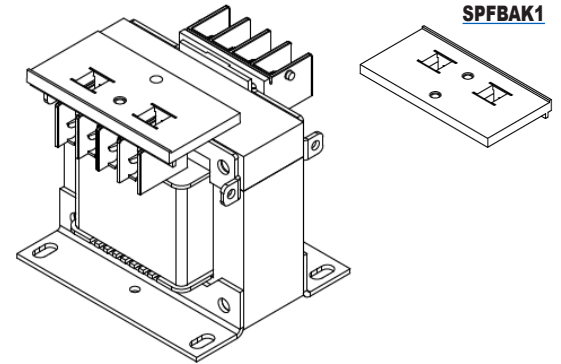

Fuse Block Adapter Kit for HPS Spartan Transformers					
Part Number	Price	Description	Pieces per package	For use with part number suffixes	Applicable VA rating
<a href="#">SPFBAK1</a>		Fuse Block Adapter Kit for use with HPS Spartan transformers	1 adapter	PR	50 to 500
				SP	50 to 1500
				ACP, MQMJ	50 to 3000

Notes: Only 1 fuse block adapter kit is required per transformer.

Add 0.38in per fuse block adapter to overall depth (column B) on units from 750 VA to 3000 VA when optional fuse block adapter is installed.

Fuse block adapter not for use when finger guards are installed.

### Finger Guards

HPS Spartan industrial control transformers up to and including 3000 VA or 30A are available with optional finger guards.

Each Finger Guard supplies either the primary or secondary side.

The Finger Guard option is not available on [SP5000ACP](#) and [SP5000MQMJ](#) units.

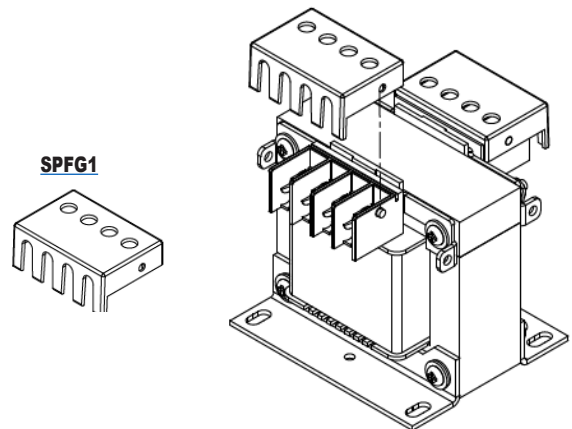

Finger Guards for HPS Spartan Transformers					
Part Number	Price	Description	Pieces per package	For use with part number suffixes	Applicable VA rating
<a href="#">SPFG1</a>		Finger Guard for use with HPS Spartan transformers	1 cover	PR	50 to 350
				SP	50 to 1500
				ACP, MQMJ	50 to 3000

Notes: Add 0.38in per finger guard to overall depth (column B) on units from 50 VA to 500 VA and 0.31in to units from 750 VA to 2000 VA when finger guard is installed.

Finger guard not for use when fuse block adapter is installed.