

# STEGO INC. 950W Fan Heaters



Foot Mounted Fan Heaters



Panel or Din Rail Mounted

To obtain the most current agency approval information, see the Agency Approval Checklist section on the specific part number's web page at [www.AutomationDirect.com](http://www.AutomationDirect.com)

## Applications

These fan heaters are designed to prevent the formation of condensation and ensure an evenly distributed interior air temperature in enclosures. These fan heaters are available with an integrated thermostat for temperature control, pre-set hygrostat for humidity control, or without integral controls.

## Features

- Compact design
- Available with integrated adjustable thermostat, fixed hygrostat or without integral controls
- Double insulated plastic housing
- Built-in overheat protection



950W Fan Heaters Specifications	
<b>Heating Element</b>	High-performance cartridge
<b>Overheat Protection</b>	With automatic reset and second-tier one shot fuse
<b>Heater Body</b>	Extruded aluminum
<b>Axial Fan, Ball Bearing</b>	Service life 50,000h at 77°F [25°C]
<b>Connection</b>	2-pole terminal with strain relief 16 AWG [1.5 mm <sup>2</sup> ] max. solid wire or stranded wire with wire end ferrules, 0.8 N-m max.clamping torque
<b>Housing</b>	Plastic, UL 94V-0, black
<b>Mounting - Footed</b>	M5 screws (not included)
<b>Mounting - Panel or Din Rail</b>	Clip for 35mm DIN rail, EN 60715 or M6 screws (not included)
<b>Mounting Position</b>	Horizontal only
<b>Recommended Mounting Distance</b>	Sides: 0.79 in [20mm] Bottom: 0.91 in [23mm] Above: 3.94 in [100mm]
<b>Operating / Storage Temperature<sup>1</sup></b>	-49 to 158°F [-45 to 70°C]
<b>Operating / Storage Humidity</b>	Max. 90% RH (non-condensing)
<b>Protection Class</b>	II (double insulated)
<b>Protection Type</b>	IP20
<b>Approvals</b>	CE, UL Recognized File No. E234324, RoHS 2 compliant

*Note: <sup>1</sup> Operating temperature of heater with integrated hygrostat: +32° to +140°F [0° to +60°C]*

950W Foot Mounted Fan Heaters							
Part Number	Price	Heating Capacity	Operating Voltage	Max Inrush	Setting Range <sup>1</sup>	Air flow, free blowing	Weight (approx.)
030599-00	\$187.00	950W	120V AC, 50/60 Hz	8.0 A continuous	32 to 140°F	94 cfm [160 m <sup>3</sup> /h]	49.6 oz [1406g]
030599-02	\$156.00				none (no integrated controls)		
030510-00	\$187.00		230V AC, 50/60 Hz	4.0 A continuous	0 to 60°C		
030510-02	\$222.00				65% RH, factory set		
030510-07	\$156.00				none (no integrated controls)		

*Note: <sup>1</sup> Switching difference 12.6 °F ± 7°F tolerance [7K ± 4K]*

950W Panel or Din Rail Mounted Fan Heaters							
Part Number	Price	Heating Capacity	Operating Voltage	Max Inrush	Setting Range <sup>1</sup>	Air flow, free blowing	Weight (approx.)
130599-00	\$197.00	950W	120V AC, 50/60 Hz	8.0 A continuous	32 to 140°F	94 cfm [160 m <sup>3</sup> /h]	49.6 oz [1406g]
130599-02	\$194.00				none (no integrated controls)		
130510-00	\$197.00		230V AC, 50/60 Hz	4.0 A continuous	0 to 60°C		
130510-02	\$231.00				65% RH, factory set		
130510-03	\$165.00				none (no integrated controls)		

*Note: <sup>1</sup> Switching difference 12.6 °F ± 7°F tolerance [7K ± 4K]*

# STEGO INC. 950W Fan Heaters

## Dimensions

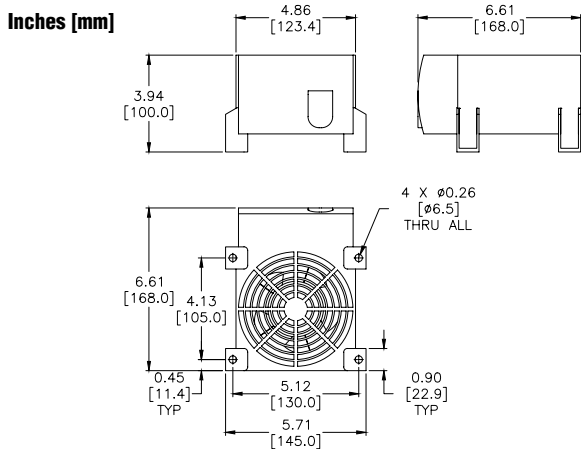

**950W Foot Mounted Fan Heaters**

## Wiring Diagram

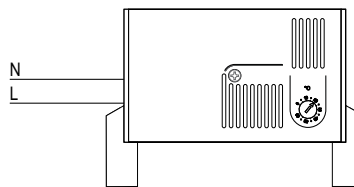

**Note:** When wiring 230 volt units for North American installations "L" (line) and "N" (neutral) will be used as "L1" (line1) "L2" (line2) respectively with no neutral connection.

## Dimensions

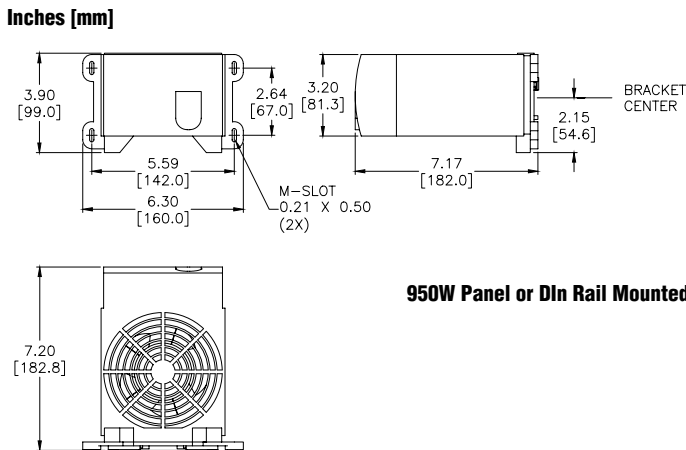

**950W Panel or DIN Rail Mounted Fan Heaters**

## Wiring Diagram

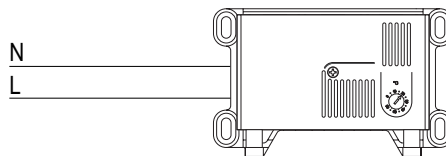

**Note:** When wiring 230 volt units for North American installations "L" (line) and "N" (neutral) will be used as "L1" (line1) "L2" (line2) respectively with no neutral connection.

Please see our website [www.AutomationDirect.com](http://www.AutomationDirect.com) for complete engineering drawings.



# 1200W PTC Fan Heaters



Foot Mounted PTC Fan Heaters



Panel or Din Rail Mounted PTC Fan Heaters

## Applications

These compact high-performance PTC fan heaters are designed to prevent formation of condensation and provide an evenly distributed interior air temperature in enclosures. These fan heaters were designed as stationary units for installation on the bottom of enclosures.

## Features

- Compact design
- Built-in overheat protection
- Double insulated plastic housing
- Integrated adjustable thermostat



1200W PTC Fan Heaters Specifications	
<b>Heating Element</b>	PTC resistor – temperature limiting
<b>Overheat Protection</b>	Built-in temperature limiter
<b>Axial Fan, Ball Bearing</b>	Service life 50,000h at 77°F [25°C]
<b>Connection</b>	2-pole terminal with strain relief 16 AWG [1.5 mm <sup>2</sup> ] max. solid wire or stranded wire with wire end ferrules, 0.8 N·m max.clamping torque
<b>Housing</b>	Plastic, UL 94V-0, black
<b>Mounting - Footed</b>	M5 screws (not included)
<b>Mounting - Panel or Din Rail</b>	Clip for 35mm DIN rail, EN 60715 or M6 screws (not included)
<b>Mounting Position</b>	Horizontal
<b>Recommended Mounting Distance</b>	Sides: 1.97 in [50mm] Bottom: 0.91 in [23mm] Above: 3.94 in [100mm]
<b>Operating / Storage Temperature</b>	-49 to 158°F [-45 to 70°C]
<b>Operating / Storage Humidity</b>	Max. 90% RH (non-condensing)
<b>Protection Class</b>	II (double insulated)
<b>Protection Type</b>	IP20
<b>Approvals</b>	CE, UL Recognized File No. E234324 & E150057, RoHS 2 compliant

To obtain the most current agency approval information, see the Agency Approval Checklist section on the specific part number's web page at [www.AutomationDirect.com](http://www.AutomationDirect.com)

1200W Foot Mounted PTC Fan Heaters							
Part Number	Price	Heating Capacity <sup>1</sup>	Operating Voltage	Max. Current (inrush)	Setting Range <sup>2</sup>	Air flow, free blowing	Weight (approx.)
030609-00	\$203.00	1200W	120V AC, 50/60 Hz	16.0 A	32 to 140°F	94 cfm [160 m <sup>3</sup> /h]	41.6 oz [1179g]
030609-01	\$165.00				none (no integrated controls)		
030600-00	\$203.00		230V AC, 50/60 Hz	13.0 A	0 to 60°C		
030600-01	\$165.00				none (no integrated controls)		

Notes: <sup>1</sup> At 68°F [20°C] ambient temperature  
<sup>2</sup> Switching difference 12.6 °F ± 7°F tolerance [7K ± 4K]

1200W Panel or Din Rail Mounted PTC Fan Heaters							
Part Number	Price	Heating Capacity <sup>1</sup>	Max. Current (Inrush)	Operating Voltage	Setting Range <sup>2</sup>	Air flow, free blowing	Weight (approx.)
130609-00	\$237.00	1200W	16.0 A	120V AC, 50/60 Hz	32 to 140°F	94 cfm [160 m <sup>3</sup> /h]	41.6 oz [1179g]
130609-01	\$194.00				none (no integrated controls)		
130600-00	\$237.00		13.0 A	230V AC, 50/60 Hz	0 to 60°C		
130600-01	\$194.00				none (no integrated controls)		

Notes: <sup>1</sup> At 68°F [20°C] ambient temperature  
<sup>2</sup> Switching difference 12.6 °F ± 7°F tolerance [7K ± 4K]



# 1200W PTC Fan Heaters

## Dimensions

Inches [mm]

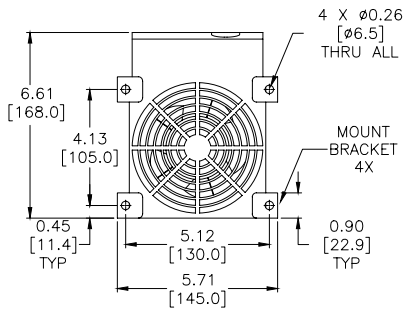
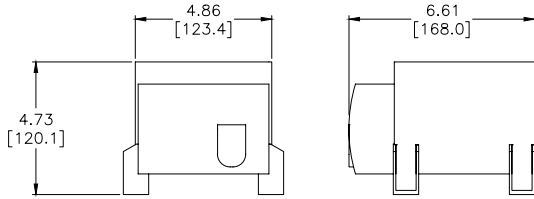

Foot Mounted 1200W PTC Fan Heaters

## Wiring Diagram

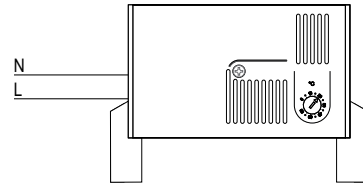

**Note:** When wiring 230 volt units for North American installations "L" (line) and "N" (neutral) will be used as "L1" (line1) "L2" (line2) respectively with no neutral connection.

## Dimensions

Inches [mm]

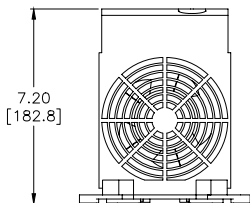
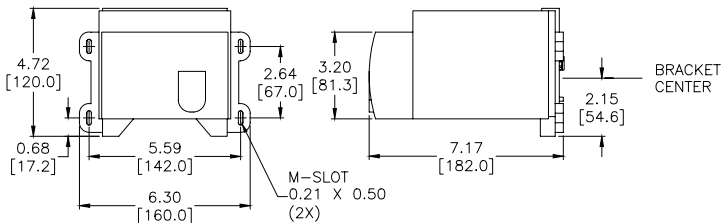

Panel or Din Rail Mounted 1200W PTC Fan Heaters

## Wiring Diagram

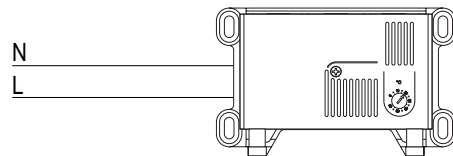

**Note:** When wiring 230 volt units for North American installations "L" (line) and "N" (neutral) will be used as "L1" (line1) "L2" (line2) respectively with no neutral connection.

Please see our website [www.AutomationDirect.com](http://www.AutomationDirect.com) for complete engineering drawings.

# Enclosure Heating and Heater Selection

## Why Heat an Enclosure?

Today's miniaturization of enclosure components results in high packing densities, which in turn results in higher temperatures within the enclosure. These high temperatures are harmful to electronic components. In response, cooling systems have become standard in many applications. However, just as critical and widely underestimated, are failures caused by the formation of moisture.

Under certain climatic conditions, moisture can build up not only in outdoor or poorly insulated enclosures, but also in highly protected and well-sealed enclosures.

## Moisture and Failure

Moisture, especially when combined with aggressive gases and dust, causes atmospheric corrosion and can result in the failure of components such as circuit breakers, busbars, relays, integrated circuit boards and transformers. The greatest danger lies in conditions where electronic equipment is exposed to relatively high air humidity or extreme variations in temperature, such as day-and-night operation or outdoor installation. Failure of components in such cases is usually caused by changing contact resistances, flashovers, creepage currents or reduced insulation properties.

## Eliminate Moisture

Moisture and corrosion will remain low if relative air humidity stays below 60%. However, relative humidity above 65% will significantly increase moisture and corrosion problems. This can be prevented by keeping the environment inside an enclosure at a temperature as little as 9°F (5°C) higher than that of the ambient air. Constant temperatures are a necessity to guarantee optimal operating conditions. Continuous temperature changes not only create condensation but they reduce the life expectancy of electronic components significantly. Electronic components can be protected by cooling during the day and heating at night.

## Thermal Management

Modern enclosure heaters are designed to protect against condensation. They heat the air inside enclosures, preventing water vapor from condensing on components while providing the greatest possible air circulation and low energy consumption.

Other heating element technology improvements include:

- Longer operating life
- Greater energy efficiencies
- Quick wiring options
- Easier mounting
- Fan heaters should be considered for larger enclosures to ensure that the entire enclosure is heated uniformly

## Heater Location

Ideally, most heaters will perform optimally when mounted near the bottom of an enclosure and used in conjunction with a control device, thermostat, and/or hygrostat. The control device may be a separate device, or it may be integral to the heater. With the controller located in an area of the cabinet that is representative of the average temperature or humidity

requirement, the heater should then be placed in a position near the bottom of the enclosure. If a separate control device is used, the heater should not be located directly beneath the controller to ensure that the controller is not influenced by direct heat from the heater.

## Heater Calculation

Follow Steps 1-5 to determine the heating requirement of an enclosure (US units - left column, metric - right)

**STEP 1: Determine the Surface Area (A) of your enclosure which is exposed to open air.**

Enclosure Dimensions:

height = \_\_\_\_\_ feet      \_\_\_\_\_ meters

width = \_\_\_\_\_ feet      \_\_\_\_\_ meters

depth = \_\_\_\_\_ feet      \_\_\_\_\_ meters

Choose Mounting Option from next page, and calculate the surface area as indicated

$$A = \text{_____ ft}^2 \text{ or } \text{_____ m}^2$$

**STEP 2: Choose the Heat Transmission Coefficient (k) for your enclosure's material of construction.**

painted steel = 0.511 W/(ft<sup>2</sup>•K)      5.5 W/(m<sup>2</sup>•K)

stainless steel = 0.344 W/(ft<sup>2</sup>•K)      3.7 W/(m<sup>2</sup>•K)

aluminum = 1.115 W/(ft<sup>2</sup>•K)      12 W/(m<sup>2</sup>•K)

plastic or insulated

stainless = 0.325 W/(ft<sup>2</sup>•K)      3.5 W/(m<sup>2</sup>•K)

$$k = \text{_____ W/(ft}^2\text{•K)} \text{ or } \text{_____ W/(m}^2\text{•K)}$$

**STEP 3: Determine the Temperature Differential (ΔT).**

A. Desired enclosure interior temp. = \_\_\_\_\_ °F      \_\_\_\_\_ °C

B. Lowest ambient (outside) temp. = \_\_\_\_\_ °F      \_\_\_\_\_ °C

Subtract B from A = Temp. diff. (ΔT) = \_\_\_\_\_ °F      \_\_\_\_\_ °C

For these calculations, ΔT must be in degrees Kelvin (K). Therefore, divide ΔT (°F) by 1.8. ΔT = \_\_\_\_\_ K

**STEP 4: Determine Heating Power (P<sub>V</sub>), if any (generated from existing components, i.e. transformer).**

$$P_V = \text{_____ W} \text{ or } \text{_____ W}$$

**STEP 5: Calculate the Required Heating Power (P<sub>H</sub>) for your enclosure based on the above values.**

If enclosure is located inside:

$$P_H = (A \times k \times \Delta T) - P_V = \text{_____ W}$$

If enclosure is located outside:

$$P_H = 2 \times (A \times k \times \Delta T) - P_V = \text{_____ W}$$

# Enclosure Mounting Types and Surface Area Calculations

## 1. Free-Standing

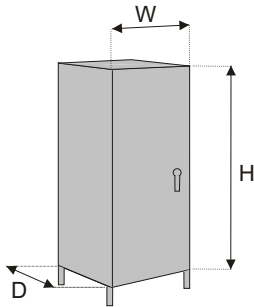

$$\text{Area (A)} = 1.8 (H \times W) + 1.8 (H \times D) + 1.8 (W \times D)$$

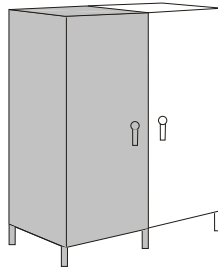

$$\text{Area (A)} = 1.8 (H \times W) + 1.4 (H \times D) + 1.8 (W \times D)$$

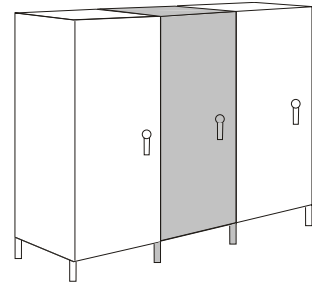

$$\text{Area (A)} = 1.8 (H \times W) + (H \times D) + 1.8 (W \times D)$$

## 2. Wall-Mounted

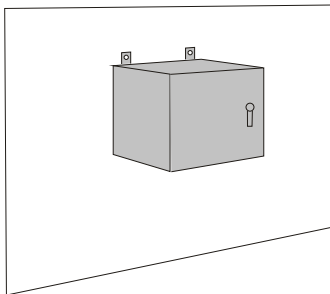

$$\text{Area (A)} = 1.4 (H \times W) + 1.8 (H \times D) + 1.8 (W \times D)$$

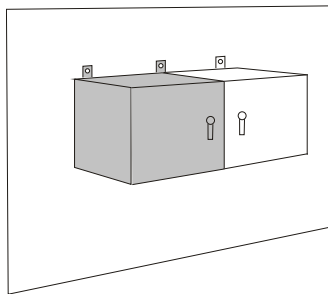

$$\text{Area (A)} = 1.4 (H \times W) + 1.4 (H \times D) + 1.8 (W \times D)$$

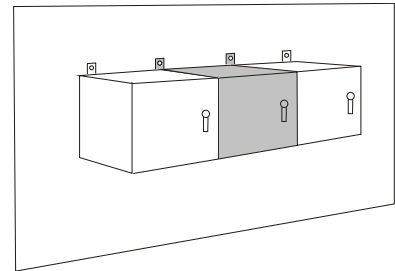

$$\text{Area (A)} = 1.4 (H \times W) + (H \times D) + 1.8 (W \times D)$$

## 3. Ground

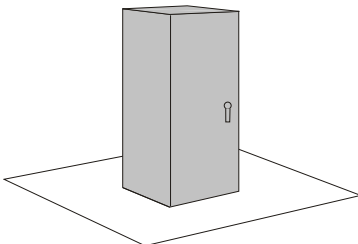

$$\text{Area (A)} = 1.8 (H \times W) + 1.8 (H \times D) + 1.4 (W \times D)$$

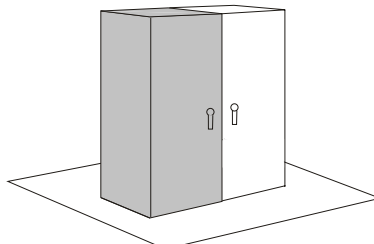

$$\text{Area (A)} = 1.8 (H \times W) + 1.4 (H \times D) + 1.4 (W \times D)$$

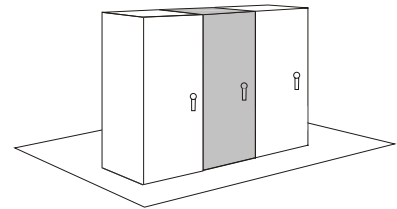

$$\text{Area (A)} = 1.8 (H \times W) + (H \times D) + 1.4 (W \times D)$$

## 4. Ground and Wall

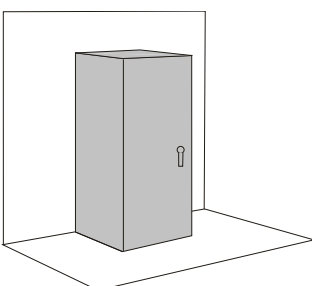

$$\text{Area (A)} = 1.4 (H \times W) + 1.8 (H \times D) + 1.4 (W \times D)$$

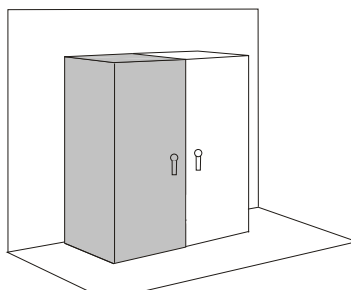

$$\text{Area (A)} = 1.4 (H \times W) + 1.4 (H \times D) + 1.4 (W \times D)$$

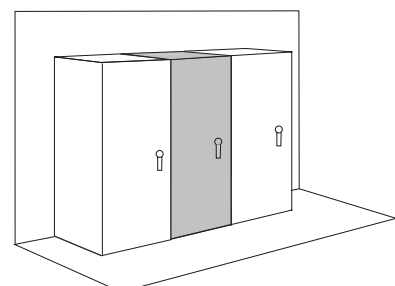

$$\text{Area (A)} = 1.4 (H \times W) + (H \times D) + 1.4 (W \times D)$$