



# Drive Couplings

## Drive Couplings Overview

Rotating shaft-driven mechanical components are commonly used in all forms of machinery that perform the various processes and functions of modern industry. Perfect alignment of shafts and rotating components is desired, but it is nearly impossible to build a real-world machine in which adjacent shaft ends align perfectly.

Adjacent shafts can be misaligned in 3 orientations, angular, parallel and axial, see figure below. Misalignment will place stresses on shafts and related parts of the assembly such as bearings, which can result in early failure of both.

Drive couplings can be used to compensate for shaft misalignment, whether the misalignment is an intentional or an unintentional part of the design. When designing or modifying a system, there are essential factors to consider for choosing the correct couplings for the application.

### Design/Selection Factors:

(Refer to the specification tables herein for the particular specifications of each type of drive coupling.)

- **RPM:** For higher rpm applications, choose Jaw/Spider or Beam-Style Servo couplings. For lower rpm, consider Double-Loop or Oldham couplings.
- **Torque:** Consider the torque requirements of the application, and the torque specifications of the different drive coupling types. peak torque generally occurs at start-up, operating torque at steady-state operation, and reversing or braking torque during rapid acceleration or deceleration or direction changes.
- **Backlash:** Backlash is a measurement of the positional accuracy of the coupling, which is important for reversing and/or motion control applications. Zero backlash is ultimately desirable, but more expensive than necessary for low-precision applications.

For high-precision applications, choose Beam-Style Servo or Oldham couplings. For applications requiring less precision, consider Jaw/Spider or Double-Loop couplings.

- **Misalignment:** Some degree of angular, axial, or radial misalignment/displacement between shafts is almost unavoidable. Drive couplings can compensate for this misalignment.

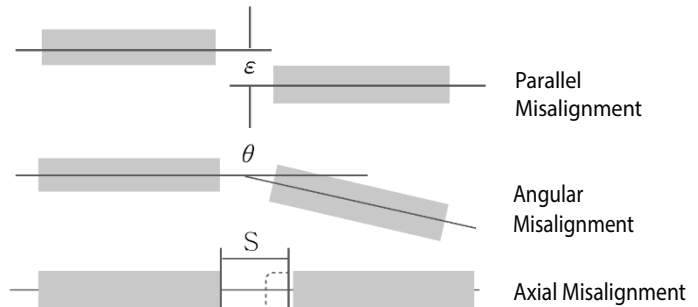

Coupling Type Comparisons				
Coupling Type	Jaw / Spider	Double Loop	Oldham	Beam-Style Servo
Representative Photo				
Purpose	most common	light duty	general purpose	high performance & torque
Hub Material	aluminum	stainless steel	aluminum	416 stainless steel
Center Material	polyurethane	Hytrel™	Delrin™	420 stainless steel
Mounting Method	clamp	set screw	clamp	set screw
Electrical Isolation	yes	yes	yes	no
Backlash	varies	varies	zero	zero
Misalignment Capacity	++ (axial)	+++	++	+
Breakable "Mechanical Fuse"	no (fail safe)	no	yes	no
Relative Price	\$\$	\$\$	\$	\$\$\$

# Suremotion Drive Couplings

## Oldham Drive Couplings



### Features

- Large radial misalignment capability
- Hubs made of aluminum 2011 T8
- Center discs made of Delrin™
- Mechanical 'fuse' prevents damage to other components in over-torque conditions
- Zero backlash
- Corrosion-resistant
- Non-magnetic
- Operating temperature range: -20 to 60 °C (-4 to 140 °F)
- Electrical isolation
- Absorbs shock and isolates vibration
- Dampens resonance
- Speeds up to 3,000rpm
- Low inertia

### Applications

- General-purpose applications
- Medium-speed applications

Oldham Aluminum Clamp-Style Drive Coupling Hubs\*

Part Number*	Price	Size	Bore	Max rpm	Torque (lb-in [N·m])		Max Offset			Moment of Inertia (lb-in·s <sup>2</sup> ×10 <sup>-5</sup> )	Weight (lb)
					Peak	Static Break	Radial (in [mm])	Axial (in [mm])	Angular (°)		
<a href="#">DC-DAC19-05M</a>		19	5mm	3,000	15 [1.7]	71 [8.0]	0.016 [0.41]	0.004 [0.1]	1.5	0.518	0.032
<a href="#">DC-DAC19-04</a>	1/4 in		0.032								
<a href="#">DC-DAC19-08M</a>	8mm		0.033								
<a href="#">DC-DAC25-04</a>		25	1/4 in	3,000	35 [4.0]	115 [13.0]	0.016 [0.41]	0.004 [0.1]	2.23	0.050	0.055
<a href="#">DC-DAC25-08M</a>	8mm		0.054								
<a href="#">DC-DAC25-06</a>	3/8 in		0.050								
<a href="#">DC-DAC25-10M</a>	10mm		0.050								
<a href="#">DC-DAC25-12M</a>	12mm		0.051								
<a href="#">DC-DAC33-06</a>		33	3/8 in	3,000	80 [9.0]	465 [52.5]	0.016 [0.41]	0.006 [0.15]	10.0	0.097	0.095
<a href="#">DC-DAC33-10M</a>	10mm		0.095								
<a href="#">DC-DAC33-12M</a>	12mm		0.095								
<a href="#">DC-DAC33-08</a>	1/2 in		0.093								
<a href="#">DC-DAC33-14M</a>	14mm		0.091								
<a href="#">DC-DAC33-10</a>	5/8 in		0.088								
<a href="#">DC-DAC33-16M</a>	16mm		0.087								
<a href="#">DC-DAC41-08</a>		41	1/2 in	3,000	150 [16.9]	500 [56.5]	0.020 [0.51]	0.006 [0.15]	3	28.1	0.186
<a href="#">DC-DAC41-14M</a>	14mm		0.181								
<a href="#">DC-DAC41-10</a>	5/8 in		0.177								
<a href="#">DC-DAC41-16M</a>	16mm		0.172								
<a href="#">DC-DAC41-19M</a>	19mm		0.168								
<a href="#">DC-DAC41-12</a>	3/4 in		0.163								
<a href="#">DC-DAC50-08</a>		50	1/2 in	3,000	265 [29.9]	840 [94.9]	0.020 [0.51]	0.008 [0.2]	66.7	0.260	0.255
<a href="#">DC-DAC50-14M</a>	14mm		0.249								
<a href="#">DC-DAC50-10</a>	5/8 in		0.244								
<a href="#">DC-DAC50-16M</a>	16mm		0.238								
<a href="#">DC-DAC50-19M</a>	19mm		0.233								
<a href="#">DC-DAC50-12</a>	3/4 in		0.227								
<a href="#">DC-DAC50-16</a>	1 in		0.227								
<a href="#">DC-DAC57-10</a>		57	5/8 in	3,000	390 [44.1]	1325 [149.7]	0.020 [0.51]	0.008 [0.2]	109.7	0.457	0.439
<a href="#">DC-DAC57-16M</a>	16mm		0.439								
<a href="#">DC-DAC57-19M</a>	19mm		0.422								
<a href="#">DC-DAC57-12</a>	3/4 in		0.404								
<a href="#">DC-DAC57-16</a>	1 in		0.386								

\* A complete Oldham coupling assembly consists of two hubs and one torque disc, each of the same "size" and each purchased separately. The two hubs can be of different "bore" diameters, if needed for the application.

# Suremotion Drive Couplings

## Oldham Drive Couplings



Oldham Aluminum Clamp-Style Drive Coupling Torque Discs*			
Part Number *	Price	Size	Color
<a href="#">DC-DDS19</a>		19	black
<a href="#">DC-DDS25</a>		25	
<a href="#">DC-DDS33</a>		33	
<a href="#">DC-DDS41</a>		41	
<a href="#">DC-DDS50</a>		50	
<a href="#">DC-DDS57</a>		57	

\* A complete Oldham coupling assembly consists of two hubs and one torque disc, each of the same "size" and each purchased separately. The two hubs can be of different "bore" diameters, if needed for the application.

### Dimensions (in [mm])

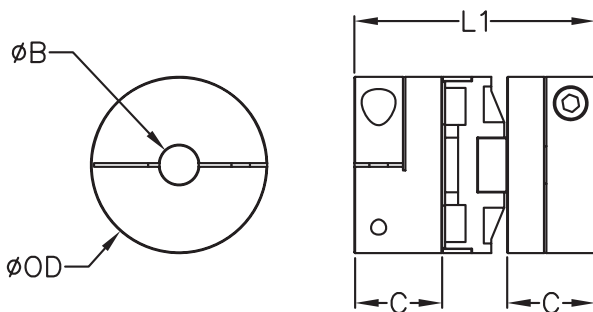

Oldham Aluminum Drive Coupling Hub Bore Dimensions		
Hubs	Sizes	ØB
<a href="#">DC-DACxx-05M</a>	19	5mm
<a href="#">DC-DACxx-04</a>	19, 25	1/4 in
<a href="#">DC-DACxx-08M</a>	19, 25	8mm
<a href="#">DC-DACxx-06</a>	25, 33	3/8 in
<a href="#">DC-DACxx-10M</a>	25, 33	10mm
<a href="#">DC-DACxx-12M</a>	25, 33	12mm
<a href="#">DC-DACxx-08</a>	33, 41, 50	1/2 in
<a href="#">DC-DACxx-14M</a>	33, 41, 50	14mm
<a href="#">DC-DACxx-10</a>	33, 41, 50, 57	5/8 in
<a href="#">DC-DACxx-16M</a>	33, 41, 50, 57	16mm
<a href="#">DC-DACxx-12</a>	41, 50, 57	3/4 in
<a href="#">DC-DACxx-19M</a>	41, 50, 57	19mm
<a href="#">DC-DACxx-16</a>	50, 57	1in

Oldham Aluminum Clamp-Style Drive Coupling Assembly Dimensions*					
Size	Components	Cap Screw	C	L1**	ØOD
			(in [mm])		
<b>19</b>	(2) DC-DAC19-xxx + (1) DC-DDS19	#4-40	0.37 [9.4]	1.02 [25.9]	0.75 [19.1]
<b>25</b>	(2) DC-DAC25-xxx + (1) DC-DDS25	M3	0.46 [11.7]	1.28 [32.5]	1.00 [25.4]
<b>33**</b>	(2) DC-DAC33-xxx + (1) DC-DDS33	M4	0.59 [15.0]	1.89 [48.0]	1.31 [33.3]
<b>41</b>	(2) DC-DAC41-xxx + (1) DC-DDS41	M4	0.70 [17.8]	2.00 [50.8]	1.63 [41.4]
<b>50</b>	(2) DC-DAC50-xxx + (1) DC-DDS50	M5	0.81 [20.6]	2.35 [59.7]	1.97 [50.0]
<b>57</b>	(2) DC-DAC57-xxx + (1) DC-DDS57	M6	1.12 [28.4]	3.07 [78.0]	2.25 [57.2]

\* Assembly dimensions are for any (2) hubs + (1) torque disc of the same "size" as assembled. Among components of the same "size," the only dimension that varies is the hub bore diameter (ØB), which is shown separately.

\*\* When DC-DAC33-08 is used with another DC-DAC33-xx bore size, L1 = 45. When 2 DC-DAC33-08 are used together, L1 = 42

See our website: [www.AutomationDirect.com](http://www.AutomationDirect.com) for complete Engineering drawings.



# Drive Couplings

## Accessories – Bore Reducers



### Features

- For use in all SureMotion drive coupling hubs to reduce bore size
- Split-collar design with 2 set screw flats will not mark shaft
- 25% greater holding power than standard split collar
- Hardened stainless steel

Bore Reducers – Stainless Steel Clamping Type						
Part Number	Price	Outside Diameter		Inside Diameter		Length
		Nominal	Actual	Nominal	Actual	
<a href="#">DC-BRS04-02</a>		1/4 in	0.250 in	1/8 in	0.125 in	0.221 in
<a href="#">DC-BRS04-04M</a>				4mm	4mm	
<a href="#">DC-BRS04-03</a>				3/16 in	0.1875 in	
<a href="#">DC-BRS04-05M</a>				5mm	5mm	
<a href="#">DC-BRS08-06M</a>		1/2 in	0.500 in	6mm	6mm	0.449 in
<a href="#">DC-BRS08-04</a>				1/4 in	0.25 in	
<a href="#">DC-BRS08-05</a>				5/16 in	0.3125 in	
<a href="#">DC-BRS08-08M</a>				8mm	8mm	
<a href="#">DC-BRS08-06</a>				3/8 in	0.375 in	
<a href="#">DC-BRS08-10M</a>				10mm	10mm	
<a href="#">DC-BRS10-10M</a>		5/8 in	0.625 in	10mm	10mm	0.460 in
<a href="#">DC-BRS10-07</a>				7/16 in	0.4375 in	
<a href="#">DC-BRS10-12M</a>				12mm	12mm	
<a href="#">DC-BRS10-08</a>				1/2 in	0.5 in	
<a href="#">DC-BRS10-14M</a>				14mm	14mm	
<a href="#">DC-BRS10-09</a>				9/16 in	0.5625 in	
<a href="#">DC-BRS12-06</a>		3/4 in	0.750 in	3/8 in	0.375 in	0.646 in
<a href="#">DC-BRS12-12M</a>				12mm	12mm	
<a href="#">DC-BRS12-08</a>				1/2 in	0.5 in	
<a href="#">DC-BRS12-10</a>				5/8 in	0.625 in	
<a href="#">DC-BRS12-16M</a>				16mm	16mm	
<a href="#">DC-BRS12-11</a>				11/16 in	0.6875 in	
<a href="#">DC-BRS14-14M</a>		7/8 in	0.875 in	14mm	14mm	0.755 in
<a href="#">DC-BRS14-10</a>				5/8 in	0.625 in	
<a href="#">DC-BRS14-16M</a>				16mm	16mm	
<a href="#">DC-BRS14-11</a>				11/16 in	0.6875 in	
<a href="#">DC-BRS14-18M</a>				18mm	18mm	
<a href="#">DC-BRS14-12</a>				3/4 in	0.75 in	
<a href="#">DC-BRS16-10</a>		1 in	1.000 in	5/8 in	0.625 in	0.773 in
<a href="#">DC-BRS16-18M</a>				18mm	18mm	
<a href="#">DC-BRS16-12</a>				3/4 in	0.75 in	
<a href="#">DC-BRS16-20M</a>				20mm	20mm	
<a href="#">DC-BRS16-13</a>				13/16 in	0.8125 in	
<a href="#">DC-BRS16-14</a>				7/8 in	0.875 in	
<a href="#">DC-BRS20-22M</a>		1-1/4 in	1.250 in	22mm	22mm	0.793 in
<a href="#">DC-BRS20-24M</a>				24mm	24mm	
<a href="#">DC-BRS20-25M</a>				25mm	25mm	
<a href="#">DC-BRS20-16</a>				1 in	1.0 in	
<a href="#">DC-BRS20-17</a>				1-1/16 in	1.0625 in	
<a href="#">DC-BRS20-18</a>				1-1/8 in	1.125 in	