

DL305 Base Specifications

5-slot I/O base
(local or expansion)

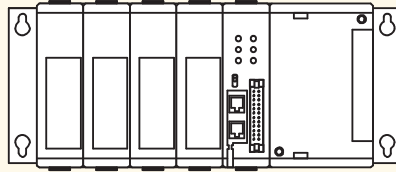

10-slot I/O base
(local or expansion)

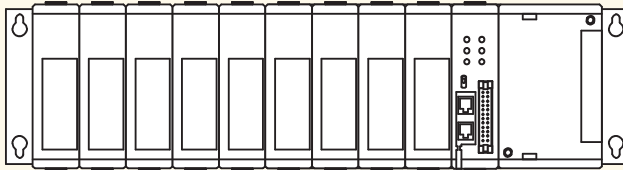

(Bases provide built-in power supplies)

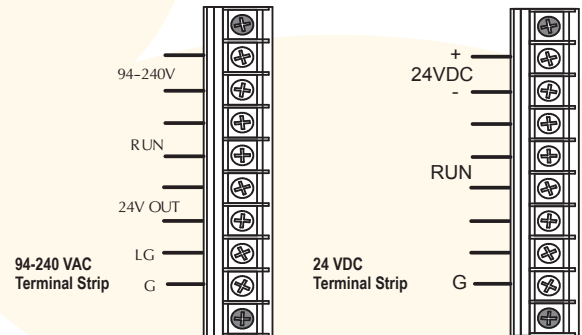

	D3-05BDC \$362.00	D3-10BDC \$461.00
Number of Slots	5	10
Local CPU Base	Yes	Yes
Expansion Base	Yes CPU base and two expansion bases. If CPU base is 5-slot, then the expansion bases must be 5-slot also.	Yes CPU base and one expansion bases. If CPU base is 10-slot, then the expansion bases must be 10-slot or 5-slot.
Input Voltage Range	20.5-30 VDC <10% ripple	20.5-30 VDC <10% ripple
Base Power Consumption	48 Watts	65 Watts
Inrush Current Max.	30A	30A
Dielectric Strength	1500VAC for one minute between 24VDC input terminals and run output	1500VAC for one minute between 24VDC input terminals and run output
Insulation Resistance	>10M ohm at 500VDC	>10M ohm at 500VDC
Power Supply Output (Voltage Ranges and Ripple)	(5VDC) 4.75-5.25 V 5% ripple (9VDC) 8.5-10V 5% ripple (24VDC) 20-28V 5% ripple	(5VDC) 4.75-5.25 V 5% ripple (9VDC) 8.5-10V 5% ripple (24VDC) 20-28V 5% ripple
5VDC Current Supplied	1.4 A	1.4 A
9VDC Current Supplied	0.8 A	1.7 A
24VDC Current Supplied	0.5 A	0.5 A
Auxiliary 24VDC Output	None	None
Run Relay	250VAC 4A (resistive load)	250VAC, 4A (resistive load)
Fuses	4A (250V) User-replaceable	4A (250V) User-replaceable
Dimensions W/H/D	11.42 x 4.85 x 4.41 in. (290 x 123 x 112 mm)	18.3 x 4.85 x 4.41 in. (465 x 123 x 112 mm)
Weight	34oz. (964g)	50.5 oz. (1432g)

D3-350 Addressing

Using "-1" bases

The D3-350 CPU can be installed in legacy DL305 bases or the "-1" bases. Note: These I/O addressing configurations are for the bases with "-1" on the end of the part number. If you are using an older series base, refer to the User's Manual appendix for correct addressing.

I/O addressing

When the D3-350 CPU is installed in a "-1" base and all expansion bases are also "-1" bases, the addressing scheme is very simple. 16 I/O points are assigned to each slot. This applies even if the slot contains an 8-point module or if the slot is empty. Expansion base addresses follow in succession from the previous base. Input modules are assigned addresses X0 through X777. Output modules are assigned address Y0 through Y777.

D3-05BDC base using 8-pt. I/O modules

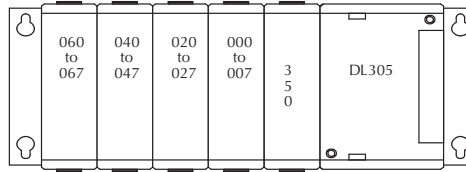

D3-05BDC base using 16-pt. I/O modules

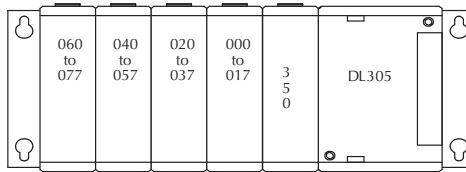

5-Slot Base Example Configurations

-1 bases

5-slot local
Total I/O: 64

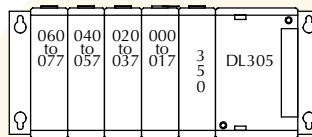

5-slot local and two 5-Slot expansions
Total I/O: 224

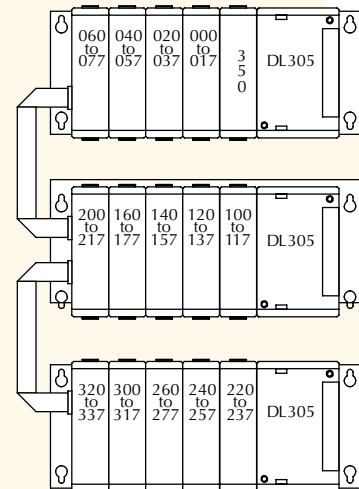

5-slot local and 5-slot expansions
Total I/O: 144

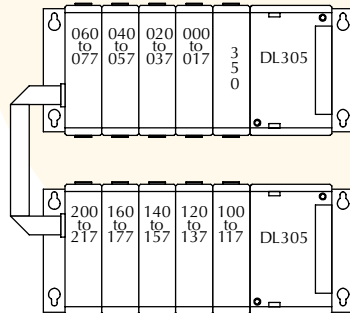

10-Slot Base Example Configurations

10-slot local and 5 slot expansion
Total I/O: 224

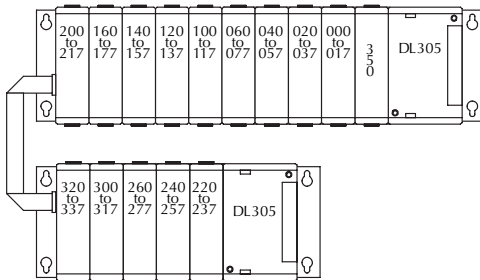

-1 bases

10 slot local and 10 slot expansion
Total I/O: 304

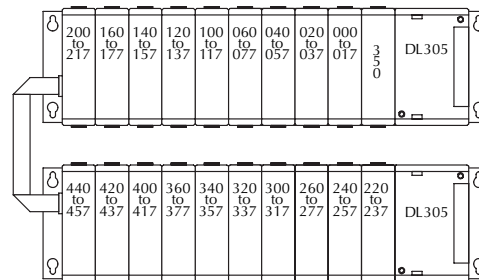

10 slot local
Total I/O: 144

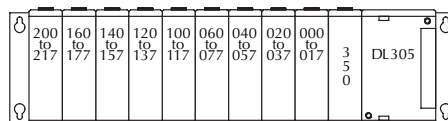

Power Budget

Managing your power resource

The I/O configuration depends on your choice of I/O modules, bases and I/O location. When determining the types and quantity of I/O modules you will be using, it's important to remember there is a limited amount of power available from the power supply.

The chart on the next page indicates the power supplied and used by each DL305

device. The adjacent chart shows an example of how to calculate the power used by your particular system. These two charts should make it easy for you to determine if the devices you have chosen fit within the power budget of your system configuration.

If the I/O you have chosen exceeds the maximum power available from the power

supply, you can resolve the problem by shifting some of the modules to an expansion base.

WARNING: IT IS EXTREMELY IMPORTANT TO CALCULATE THE POWER BUDGET CORRECTLY. IF YOU EXCEED THE POWER BUDGET, THE SYSTEM MAY OPERATE IN AN UNPREDICTABLE MANNER, WHICH MAY RESULT IN A RISK OF PERSONAL INJURY OR EQUIPMENT DAMAGE.

Example: How to calculate your power usage

The following example shows how to calculate the power budget for the DL305 system. The examples are constructed around a single 5-slot base using the devices shown. It is recommended you construct a similar table for each base in your DL305 system.

- Using a chart similar to the one below, fill in column 2.
- Using the tables on the opposite page, enter the current supplied and used by each device (columns 3, 4, and 5). Devices which fall into the "Other" category (Row D) are devices such as the Handheld Programmer or a Data Communication Unit, which also have power requirements, but do not directly plug into the base.

- Add the current used by the system devices (columns 3, 4, and 5), starting with Slot 1, then put the total in the row labeled "Maximum Current Required" (Row E).
- Subtract the row labeled "Maximum Current Required" (Row E), from the row labeled "Current Supplied" (Row B). Place the difference in the row labeled "Remaining Current" (Row F).
- If "Maximum Current Required" is greater than "Current Supplied" in columns 3, 4 or 5, the power budget will be exceeded. It will be unsafe to use this configuration and you will need to restructure your I/O configuration.

Use ZIPLinks to reduce power requirements

If your application requires a lot of relay outputs, consider using the ZIPLink AC or DC relay output modules. These modules can switch high current (10A) loads without putting a load on your base power budget. Refer to the Wiring Solutions section in this catalog for more information.

This logo is placed next to I/O modules that are supported by the ZipLink connection systems. See the I/O module specifications at the end of this section.



Example of System Power Requirements Calculation

A	Column 1	Column 2	Column 3	Column 4	Column 5
	<i>Base # 0</i>	<i>Device Type</i>	<i>5 VDC (mA)</i>	<i>9VDC (mA)</i>	<i>24V(mA)</i>
B	<i>Current Supplied</i>				
	5-slot Base	D3-05BDC	1400	800	500
C	<i>Current Required</i>				
	CPU Slot	D3-350	500	0	0
	Slot 0	D3-16NE3	0	130	0
	Slot 1	D3-16NE3	0	130	0
	Slot 2	F3-08TAS-1	0	160	0
	Slot 3	F3-08TAS-1	0	160	0
D	<i>Other</i>				
	Handheld prog D2-HPP		200	0	0
E	Maximum Current Required		700	580	0
F	Remaining Current		700	220	500

DL305 Power Requirements

This section shows the amount of power supplied by the base power supplies and the amount of power used by each DL305 device. Note the base power supplies provide three internal voltages (5V, 9V, 24V). The chart shows how much power from each of these power sources is required for each DL305 device. Use this information when calculating the power budget for your system.

In addition to the three internal power sources, the DL305 bases provide an external power connection. There is 24VDC available from the 24VDC output terminals on the bases (except D3-05BDC and D3-10BDC).

The 24VDC can be used to power external devices or DL305 modules that require external 24VDC. The power used from this external 24VDC output reduces the internal system 24VDC that is available to the modules by an equal amount. When using the 24VDC output at the base terminal, it is recommended that 100mA not be exceeded.

Power Consumed				
Device	5V(mA)	9V(mA)	24V(mA)	Ext req.
CPUs				
<u>D3-350</u>	500	0	0	0
DC Input Modules				
<u>D3-08ND2</u>	0	10	112	0
<u>F3-16ND3F</u>	0	148	68	0
AC Input Modules				
<u>D3-08NA-1</u>	0	10	0	0
<u>D3-08NA-2</u>	0	10	0	0
AC/DC Input Modules				
<u>D3-16NE3</u>	0	130	0	0
DC Output Modules				
<u>D3-08TD1</u>	0	20	24	0
<u>D3-08TD2</u>	0	30	0	0
<u>D3-16TD1-1</u>	0	40	96	0
<u>D3-16TD2</u>	0	180	0	0
AC Output Modules				
<u>F3-08TAS-1</u>	0	200	0	0
<u>F3-16TA-2</u>	0	250	0	0
<u>D3-16TA-2</u>	0	400	0	0

Power Supplied				
Device	5V(mA)	9V(mA)	24V(mA)	24 V (mA)
<u>D3-05BDCD3-10BDC</u>	900 900	2000 2000	500 500	None None
Power Consumed				
Device	5V(mA)	9V(mA)	24V(mA)	External required
Relay Output Modules				
<u>D3-08TR</u>	0	360	0	0
<u>F3-08TRS-1</u>	0	296	0	0
<u>F3-08TRS-2</u>	0	296	0	0
<u>D3-16TR</u>	0	480	0	0
Analog Temperature and Thermocouple Modules				
<u>F3-04ADS</u>	0	183	50	0
<u>F3-08AD-1</u>	0	45	55	0
<u>F3-08THM-n</u>	0	50	34	0
<u>F3-16AD</u>	0	55	65	0
<u>F3-04DA-1</u>	0	144	108	0
<u>F3-04DAS</u>	0	154	145	0
Communications and Networking				
<u>D3-232-DCU</u>	500	0	0	Optional 5V@500mA
Programming				
<u>D2-HPP</u>	200	0	0	0
Specialty CPUs				
<u>F3-OMUX-1*</u>	409	0	0	0
<u>F3-OMUX-2</u>	262	0	150	0
<u>F3-PMUX-1</u>	455	0	0	0
Operator Interface				
<u>C-more Micro-Graphic</u>	210	0	0	0

* F3-OMUX-1 -As of 3/2021 CPU is no longer available.

Dimensions and Installation

It is important to understand the installation requirements for your DL305 system. This will help ensure that the DL305 products operate within their environmental and electrical limits.

Plan for safety

This catalog should never be used as a replacement for the user manual. The user manuals, D3-USER-M and D3-350-M (available for download from our web site), contain important safety information that must be followed. The system installation should comply with all appropriate electrical codes and standards.

Base dimensions and mounting orientation

Use the diagrams to the right to make sure the DL305 system can be installed in your application. DL305 bases must be mounted horizontally to ensure proper airflow for cooling purposes. It is important to check these dimensions against the conditions required for your application. For example, it is recommended that you leave 1.5" depth for ease of access and cable clearance. However, your distance may be greater or less. Also, check the installation guidelines for the recommended cabinet clearances.

Specification	Rating
Storage Temperature	-4°F - 158°F (-20°C to 70°C)
Ambient Operating Temperature	32°F - 131°F (0° to 55°C)
Ambient Humidity	30% - 95% relative humidity (non-condensing)
Vibration Resistance	MIL STD 810C, Method 514.2
Shock Resistance	MIL STD810, Method 516.2
Noise Immunity	NEMA (ICS3-304)

DL305 mounting depths

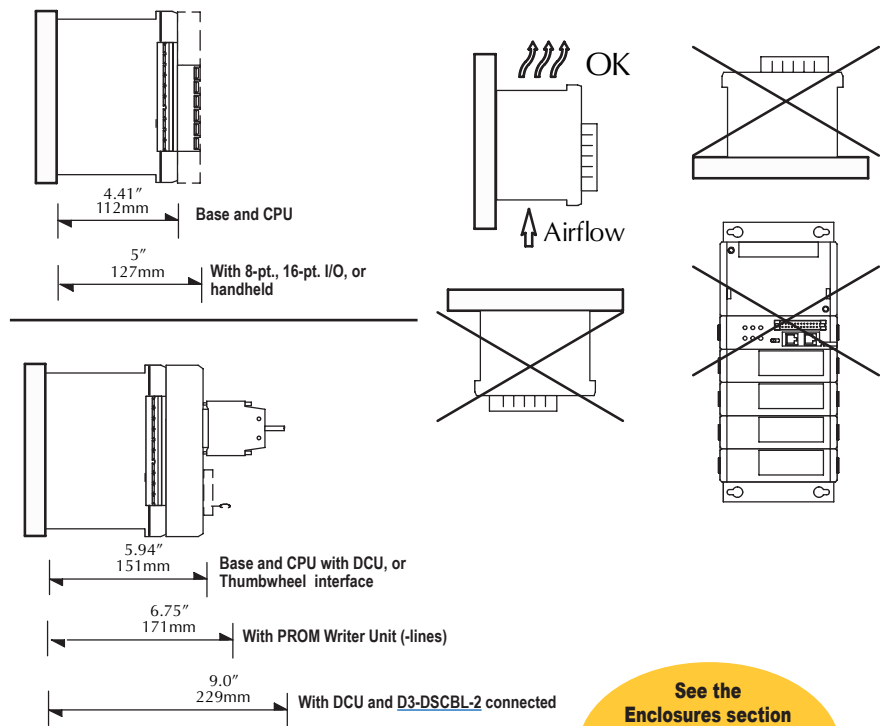

See the Enclosures section in this catalog for an enclosure that may be suitable for your application

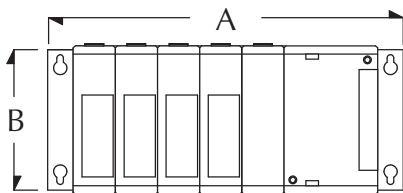

Base	Price	A	B
D3-08B-1	\$362.00	14.0" 355.6 mm	7.50" 190.5 mm
D3-10BDC	\$461.00	20.7" 525.7 mm	7.50" 190.5 mm

