

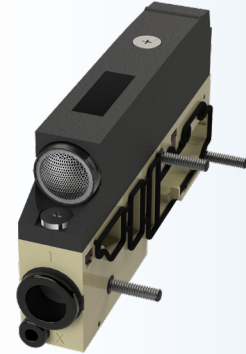







PAL System - Compressed Air Connection Modules

Compressed Air Connection Modules

The PAL-P12 compressed air connection module is the primary interface for the compressed air supply and PAL system solenoid valves. It features a 1/2" push-to-connect main supply and 5/32" (4mm) pilot supply. Used in the default configuration, pilot pressure of 3 to 8 bar (43 to 116 psi) is supplied to port X, allowing the main supply to be in the range of vacuum to 10 bar (145 psi). If the total system is operated in the range of 3.5 to 8 bar (51 to 116 psi), the PAL-P12 can be easily converted to require only the single main supply connection for complete operation.

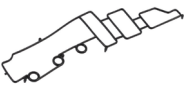
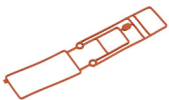

PAL System - Compressed Air Connection Module					
Item	Part No.	Price	Description	Weight (lbs)	Drawing Link
	PAL-P12	\$30.50	NITRA pneumatic compressed air module, left supply/exhaust, Cv=3.76, 1/2in push-to-connect tubing inlet(s), silenced exhaust(s), 5/32in (4mm) push-to-connect tubing pilot(s), IP65. For use with PAL series.	0.45	PDF
PAL System - Intermediate Air Connection Modules					
	PAL-M12	\$66.00	NITRA pneumatic air module, intermediate through, Cv=3.76, 1/2in push-to-connect tubing inlet(s), 5/32in (4mm) push-to-connect tubing pilot(s), IP65. For use with PAL series. Without additional power connection.	0.4	PDF
	PAL-M12P	\$113.00	NITRA pneumatic air module, intermediate through, Cv=3.76, 1/2in push-to-connect tubing inlet(s), 5/32in (4mm) push-to-connect tubing pilot(s), IP65. For use with PAL series. Requires power cable. With additional power connection.	0.45	PDF
	PAL-PC12	\$6.75	NITRA pneumatic push-to-connect cartridge, replacement, 1/2in tubing. Package of 2. For use with PAL-P12 compressed air supply module.	0.05	PDF
	PAL-ACC13	\$4.50	NITRA pneumatic exhaust silencer, replacement. For use with PAL-P12 compressed air supply module.	0.05	N/A
	PAL-ACC14	\$8.25	NITRA gasket, replacement. Package of 10. For use with PAL series base interface between valve bases.	0.05	N/A
	PAL-ACC15	\$9.25	NITRA gasket, replacement. Package of 10. For use with PAL-P12 or PAL-SPC lower/upper body.	0.05	N/A



PAL System - Compressed Air Connection Modules

Intermediate Wiring

M8 male connector



- 1 = + VDC
- 2 = + VDC
- 3 = GND
- 4 = GND

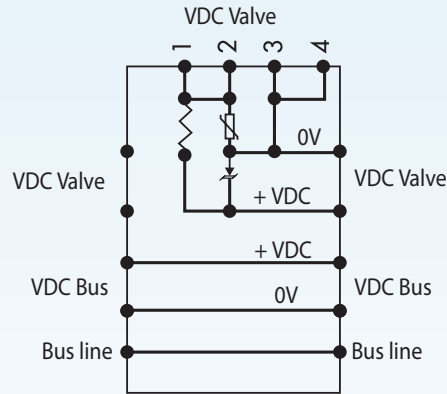
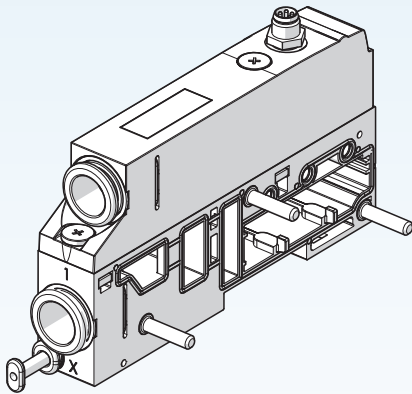

Click the icon or scan the QR code to be taken to <https://www.automationdirect.com/selectors/pal> for our online PAL system Configuration Tool for further selection assistance.

AIR - PLC - I/O



PAL System - Accessories and Mounting Options

PAL System - Accessories					
Item	Part No.	Price	Description	Weight (lbs)	Drawing Link
	PAL-ACC01	\$11.50	NITRA base mount, panel. Package of 2. For use with PAL series. Mounting screws included.	0.1	PDF
	PAL-ACC02	\$2.00	NITRA M8 protective cap, for use with PAL series.	0.05	N/A
	PAL-ACC03	\$1.00	NITRA M12 protective cap, for use with PAL series.	0.05	N/A

Mounting Options

Using the [PAL-ACC01](#)

1. Mounting to DIN rail: tighten the set screws into modules E (electrical connection) and C (closed end plate).
2. Mounting on a flat surface: use the pair of brackets part number [PAL-ACC01](#) and the M5x20 screws supplied.

You can choose where to position the brackets in relation to the base:

- 2a. Protruding brackets: Can be used to install the base + brackets unit from above. First secure the brackets to the modules E and C using the set screws, then secure everything with M5x20 screws.
 - 2b. Concealed brackets: the overall dimensions of the base are reduced. First secure the brackets to the flat top with M5x20 screws, then place the base onto the brackets and lock the two set screws provided in the modules E and C.
3. Mounting through a wall: use the brackets part number [PAL-ACC01](#). The brackets come with M6 threaded holes and can be fixed with M6 screws (not included in the supply) passing through the wall. The brackets can be fixed either protruded or concealed.

Note: Planar surfaces are required to ensure correct mounting. Avoid twisting or bending the valve units.

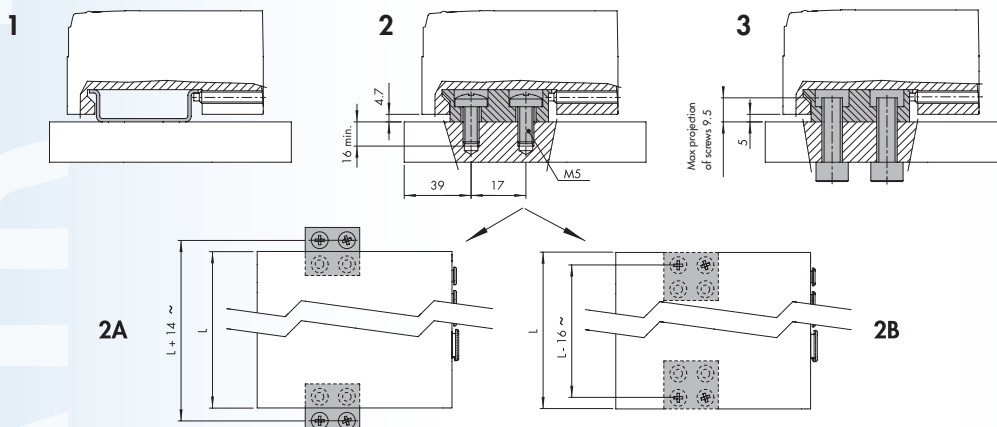



Pneumatic Automation Link (PAL)

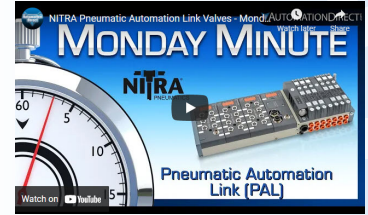

Click on the thumbnail or go to <https://www.automationdirect.com/VID-PN-0055> for a short video on the Nitra PAL system.

The Pneumatic Automation Link (PAL) system is defined as an electro-pneumatic system as it can contain both electrical I/O as well as a solenoid valve bank. In effect, a single assembly can combine solenoid valves of various types, digital or analog I/O and common power sources for all of the above.

Using a limited variety of basic components many different configurations can be built. Valves supported are compact yet have high flow ratings (Cv) and high performance. The system can be controlled by direct wiring if only pneumatic valves are used or via Ethernet/IP if a combination of electrical I/O and valves are part of your application. To simplify wiring and system design, DC power is connected through a central module using M8 connections. All PAL components come with an efficient diagnostic system.



Click or scan the QR code to be taken to <https://cdn.automationdirect.com/static/manuals/nitra-pal/nitrapal.html> for online PAL system Documentation including Manual and Module Options Insert.

PAL System - General Specifications

Nominal Supply Voltage	12 or 24 VDC		
Minimum Operating Voltage	10.8 V *		
Maximum Operating Voltage	31.2 V		
Maximum Admissible Voltage	32V **		
Power for Each Controlled Pilot	3W for 15ms, then holding 0.3 W		
Drive (for multi-pole)	PNP or NPN		
Solenoid Rating	100% ED		
Protection	Overload and short-circuit protected solenoid pilot Output		
Maximum Number of Solenoid Pilots	21 or 38 multi-pole connection; field bus 128		
Ambient Temperature	-10°C to + 50°C (at 8 bar) 14°F to 122°F (at 8 bar)		
Operating Pressure	Common supply	Port 1	5/2 and 5/3 3 to 8 bar (43 to 116 psi)
	Separate pilot supply	Assisted valves	3/2 3.5 to 8 bar (51 to 116 psi)
		Pilot pressure	Vacuum to 10bar (Vacuum to 145psi) 3 to 8 bar (43 to 116 psi)
Actuation Response Time (TRA) / Reset Response Time (TRR) at 6 bar	TRA/TRR valve 2/2 and 3/2		14 / 28 ms
	TRA/TRR valves 5/2 monostable and shut-off valve		12 / 45 ms
	TRA/TRR valve 5/2 bistable		12 / 14 ms
	TRA/TRR valve 5/3		15 / 45 ms
	TRA/TRR valve 3/2 high flow		13 / 36 ms
Fluid	Unlubricated air		
Air Quality Required	ISO 8573-1 class 4-7-3		
Degree of Protection	IP65 (with connectors connected or plugged if not used)		
Agency Approvals	CE, cURus		
* Minimum voltage 10.8V required at solenoid pilots.			
** IMPORTANT! Voltage greater than 32VDC can permanently damage the system.			