



Stepping Drives

Ever Stepper Drives

The Titanio family of drives from Ever Motion Solutions (formerly Ever Elettronica) are high performance vector stepper drives that provide industry-leading quality and control. The drives are available in Open Loop (no encoder feedback) and Closed Loop (motor-mounted encoder provides position feedback to the drive). Like most Closed Loop stepper drives, Ever's Titanio drives can alert the upper control system if a motor stalls (Stall Detection). However, the Ever Titanio drives also have Stall Detection capability in Open Loop control mode: the drive uses the motor's back EMF to monitor motor movement. This means the Titanio drives can detect and report Stall Detection without encoder feedback.

The Titanio drive technology is based on ELSE – Error Less Servo Efficient – technology pioneered by Ever. ELSE provides precise sinusoidal stepper motor current control. ELSE is built on the f4d2 (Fast Forward Feed Full Digital Drive) technology. The proprietary and patented f4d2 algorithms reduce the parasitic phase current harmonics that cause unnecessary motor heating and noisy/inefficient motor operation.

The breakthrough of ELSE technology and the f4d2 algorithms result in greatly improved phase current control and near “stepless” operation of stepper motors. The benefits of better and smoother current control include:

- drastic reduction of motor noise
- extremely smooth movement of the motor, regardless of microstep resolution
- significant damping of motor vibrations and resonances
- increased positioning accuracy
- better and more constant torque output at every rotational speed
- less heating and higher efficiency of the motor and drive system
- all drives with ELSE technology also have BEMF stall detection, with or without encoder feedback

For more information on f4d2: <https://www.everelettronica.com/en/technologies/f4d2-fast-forward-feed-full-digital-drive>

For more information on ELSE: <https://www.everelettronica.com/en/technologies/-else-technology-for-different-type-of-motors>

For more information on Closed Loop stepper technology: <https://www.everelettronica.com/en/technologies/closed-loop-of-torque-speed-and-position-systems>

The Titanio drives are available in models with complete drive setup using DIP switches only, as well as models that can be fine-tuned and set up with free Ever Studio software in addition to DIP switch setup.



Features

- ELSE® (ErrorLess Servo Efficient) step loss detection without encoder
- Quiet and smooth operation
- 36 month warranty
- Closed Loop for drive LW4D
- Protection against short circuit and open circuit
- Alarms for over/under voltage, temperature, short circuit
- Basic setup configured by DIP switches, optional advanced software setup for LW3A and LW4D drives

Ever Steppers – Drive Feature Comparison			
Drive Model	LW4D3070N2I1-00	LW3D3070N0A1-00	LW3A9030N2A1-00
Price	\$105.00	\$205.00	\$290.00
Drawing	PDF	PDF	PDF
Drive Type	2-phase digital stepper drive for hybrid stepper motors		
Supply Voltage	24–75 VDC	24–80 VDC	100–240 VAC
Pulse Input Type	Differential, Single-ended		
Step Input Modes	Differential, Single-ended, AB Quadrature	Differential, Single-ended	
Digital Input Voltage	5–24 VDC	2–24 VDC	5–24 VDC
PPR Range	200–25600 (DIP switch) 200–65536 (software)	200–51200 (DIP switch)	200–2000 (DIP switch) 200–65536 (software)
Motor Output Current Range	0.0–7.1 (A/ph rms) 0.0–10.0 (A/ph peak)	1.7–7.1 (A/ph rms) 2.4–10.0 (A/ph peak)	0.0–3.0 (A/ph rms) 0–4.2 (A/ph peak)
Digital Output	2 opto-isolated, 5–24 VDC, 100mA max NPN or PNP for Alarm and In Position	1 opto-isolated, 24VDC, 400mA max, NPN or PNP for Alarm	1 opto-isolated, 24VDC, 400mA max PNP or NPN for Alarm
Self-test Capable	Software-based (internal indexing)	Pulse Input Test (LEDs signal if the incoming pulse rate is 0Hz, <1kHz, or ≥1kHz)	Software-based (internal indexing)
Special Features	Advanced software setup	–	Basic software setup



Stepping Drives

Ever Stepper Drive Feature Overview

Vector Control

The sinusoidal phase current with "ELSE" technology keeps the motor torque constant allowing smooth and noiseless movements.

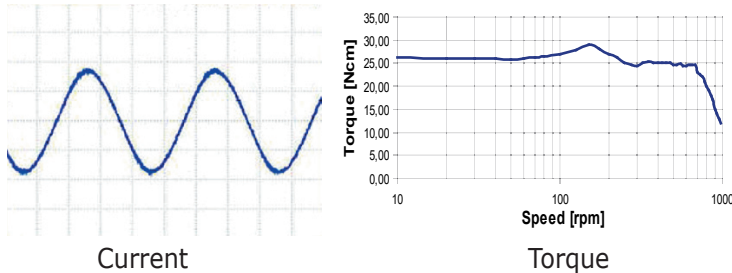

Drive Model Number Explanation

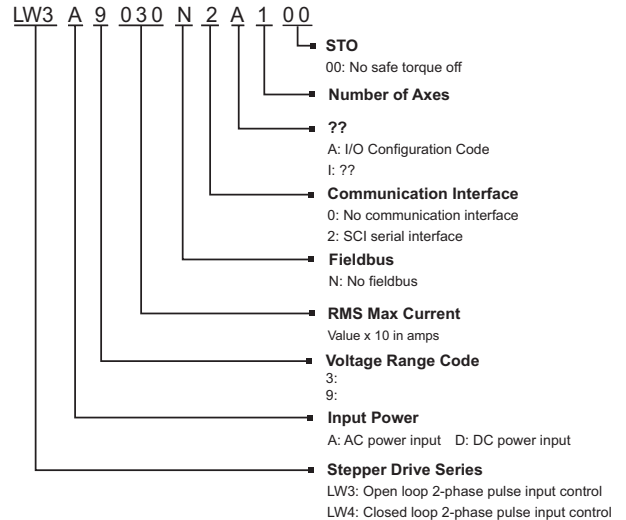

Easy Drive Configuration

- Set motor current value using dip-switches. Option to set motor current with Ever Studio software (LW3A and LW4D)
- Select step angle using roto-switches. Option to set motor current with Ever Studio software. Step angles have been emulated through software to maintain compatibility with traditional drives. Current regulation is always sinusoidal.
- Enable motor stall detection with DIP switches (LW3D, LW3A) or software (LW4D)..
By reading the motor BEMF, LWx drivers detect step loss without encoder input. Drive displays alarm status with Fault digital OUT and an LED sequence.
- DIP switches to select Step/Direction or CW/CCW control mode.
- ENABLE input can be set for active high or active low.
- 30% or 70% automatic current reduction (when motor is not moving).
- Enable "Clock Test" function during drive installation to show the presence of the high speed pulse signals via status LED flashes (LW3D).

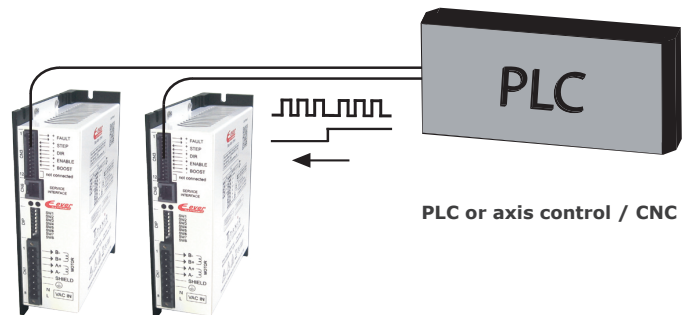

1.8° (1/4 microstep of traditional type)

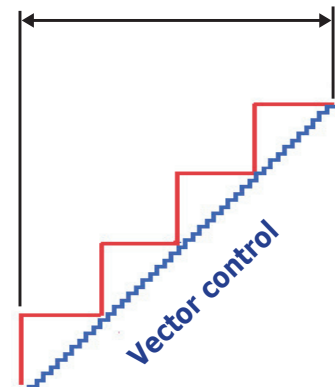

Clock frequency

Status LEDs		
LED1	LED2	Meaning
Green	Red	No incoming pulses
Green flash	Yellow	Incoming pulses < 1kHz
Green flash	Red	Incoming pulses > 1kHz

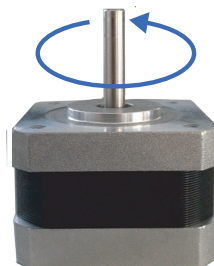



Stepping Drives

LW3A9030N2A1-00 Stepper Drive

The LW3A from Ever Motion Solutions (formerly Ever Elettronica) is a high-performance AC-input vector stepper drive from Ever's Titanio family. The LW3A is a two-phase stepper drive that can run in Open Loop mode (no encoder needed), will accept an incoming voltage of 100-240VAC, and can power hybrid bipolar stepper motors with up to 4.2A peak output current.



CAUTION: USE ONLY HIGH VOLTAGE STEPPER MOTORS, LIKE STP-MTRAC-XXXXX AND STP-MTRACH-XXXXX, WITH A HIGH-VOLTAGE STEPPER DRIVE. THE AC INPUT RESULTS IN HIGH VOLTAGE BEING APPLIED TO THE MOTOR. STANDARD LOW-VOLTAGE STEPPER MOTORS (STP-MTR-XXXXX) CAN BE DAMAGED.

The LW3A can be setup via DIP switches to run with many high-voltage SureStep motors (STP-MTRAC-xxxxx or STP-MTRACH-xxxxx). Ever's configuration software, Ever Studio, can be used to configure the drive for

phase currents and step angles (microsteps) not available via the DIP switches. Ever Studio is available as a free download from AutomationDirect (LW3A requires USB-serial programming cable EVER-PGM-2).

The stepper drive utilizes Ever's ELSE (Error Less Servo Efficient) technology that supplies the motor with sinusoidal current, resulting in reduced harmonic currents, lower motor temperature, and smoother/quieter motor operation. The LW3A has sensorless motor stall detection that detects motor missed steps (machine jams, overload conditions, etc.) without the need for encoder feedback. The drive has built-in protections that include overcurrent, under/over voltage, overheating, and motor output short circuit protection.

Download the AutomationDirect LW3A QuickStart Guide for step-by-step instructions on how use Ever Studio to fine-tune the min/max motor currents and step angle (microstep resolution). The LW3 QuickStart Guide can be found on the LW3A Item Page (link in chart below).



LW3A9030N2A1-00 Drive Specifications	
Drive Model	<u>LW3A9030N2A1-00</u>
Power Supply Voltage	100–240 VAC
Digital Input Voltage	5–24 VDC
Output current	0.0–3.0 (A/ph rms) 0–4.2 (A/ph peak)
Control mode	Pulse + Direction, CW/CCW
Power stage	H bridge bipolar chopper at 40 kHz
Feedback Interface	n/a
Digital Inputs	4 opto isolated 5–24 VDC NPN or PNP or Line Driver
Digital Outputs	1 opto isolated, 24VDC 400mA PNP or NPN for FAULT
Open or Close Loop	Open
Step Resolution	Full Step, ½, ¼, 1/8, 1/2.5, 1/5, 1/10 configurable by means of Dip-Switches and other step angle can be set with software
PPR Range	200–2000 (DIP switch) 200–65536 (software)
Safety Protections	Over/Under voltage, Over Current, Over Temperature, Short Circuit Phase/Phase and Phase/Ground
Status Monitoring	2 LEDs with guiding light (solid green and flashing red/yellow)
Operating Temperature	5 to 40 °C [41 to 104 °F]
Storage Temperature	-25 to +55 °C [-13 to 131 °F]
Operating Humidity	5–85 %
Protection class	IP20
Mounting	Wall mount
Dimensions H x L x W	152.0 x 130.0 x 46.0 mm
Weight	0.80 Kg
Agency Approvals	CE



Stepping Drives

LW3A9030N2A1-00 Input/Output Wiring

Digital Input Wiring

Differential PNP, NPN, and Line Driver type.

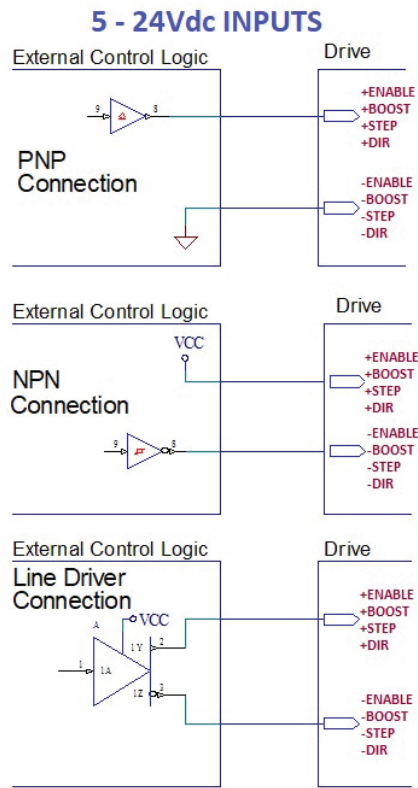

Digital Output Wiring

24VDC - PNP/NPN photo relay output (optoisolated)

$$I_{out_MAX} = 400mA$$

$$F_{MAX} = 250Hz$$

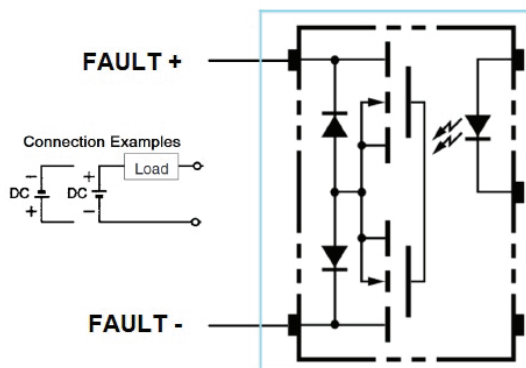



Stepping Drives

LW3A9030N2A1-00 Bipolar Drive Wiring

The LW3A AC drive allows high voltage AC stepper motors to be run in either Series or Parallel wiring. Only use step motors rated for a high DC bus voltage. Standard lower DC voltage step motors will be damaged when driven by this drive.

If the motor's rated parallel-wired current is not higher than the drive's rated current, wire the motor for parallel operation: a parallel wired motor has higher torque and speed than the same motor wired in series.

Example 1:

STP-MTRAC-34115 can be used with the LW3A drive wired in series or parallel (both values are within the drive's output range):

	Series	Parallel
STP-MTRAC-34115	2.05A	4.1A

Wire this motor in parallel to get more available torque and a higher max speed.

Example 2:

STP-MTRAC-42100 should only be used with the LW3A wired in series (the parallel-wired current exceeds the drive max output).

	Series	Parallel
STP-MTRAC-42100	4.2A	8.4A

Note: Motors with rated phase currents greater than the drive maximum 4.2A can be used. The resulting torque will be proportionally lower than the motor rated torque: The STP-MTRAC-42151 is rated for 6A (series wiring). Used with an LW3A drive, the motor will generate roughly 2/3 of the motor's rated torque.

- STP-MTRAC-42xxx
- STP-MTRACH-42xxx
- STP-MTRAC-230xx(x)
- STP-MTRAC-34156(x)

Bi-polar series

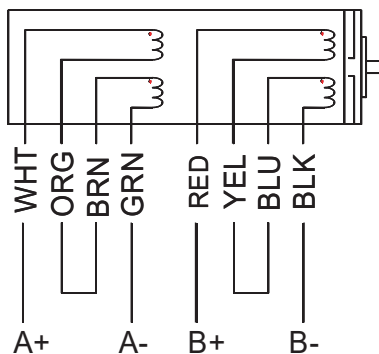

Bi-polar parallel

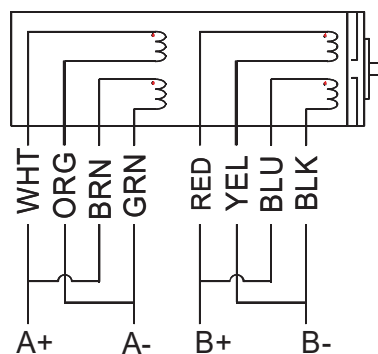

- STP-MTRAC-34075(x)
- STP-MTRAC-34115(x)

Bi-polar series

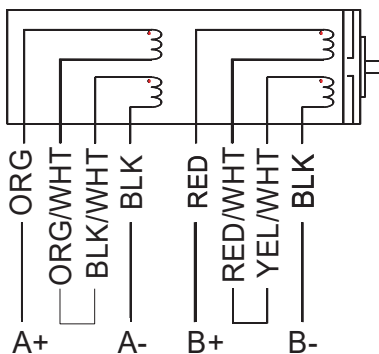

Bi-polar parallel

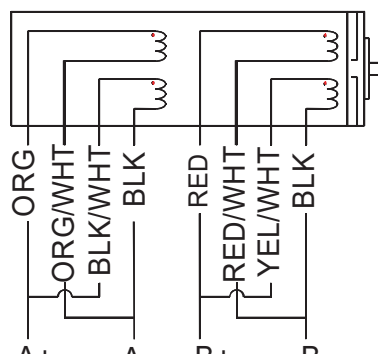



Stepping Drives

Ever Stepper Drive Accessories

Ever Stepper Drive Accessories				
Part Number	Price	Description	Drawing Links	Use With
<u>EVER-PGM-1</u>	\$89.00	Ever Elettronica programming cable, USB A connector to 4-pin connector, 6ft cable length. For use with Ever Elettronica LW4D3070N2I1-00 microstepping drive.	<u>PDF</u>	<u>LW4D3070N2I1-00</u>
<u>EVER-PGM-2</u>	\$89.00	Ever Elettronica programming cable, USB A connector to RJ11, 6ft cable length. For use with Ever Elettronica LW3A9030N2A1-00 microstepping drive.	<u>PDF</u>	<u>LW3A9030N2A1-00</u>
<u>LW4D3KIT-C0</u>	\$8.00	Ever Elettronica connector kit, for use with Ever Elettronica LW4D3070N2I1-00 microstepping drive, includes (1) drive power connector, (1) motor power connector, (1) encoder connector and (1) control signal connector.	<u>PDF</u>	<u>LW4D3070N2I1-00</u>
<u>LW4D3KIT-050</u>	\$60.00	Ever Elettronica cable kit, for use with Ever Elettronica LW4D3070N2I1-00 microstepping drive, includes (1) 1.6ft/0.5m power cable, (1) 1.6ft/0.5m motor extension cable, (1) 1.6ft/0.5m encoder cable and (1) control signal connector.	<u>PDF</u>	<u>LW4D3070N2I1-00</u>
<u>LW3D-CON-A</u>	\$10.00	Ever Elettronica drive/motor power connector, replacement. For use with Ever Elettronica LW3D3070N0A1-00 microstepping drive.	<u>PDF</u>	<u>LW3D3070N0A1-00</u>
<u>LW3D-CON-B</u>	\$18.00	Ever Elettronica control signal connector, replacement. For use with Ever Elettronica LW3D3070N0A1-00 microstepping drive.	<u>PDF</u>	<u>LW3D3070N0A1-00</u>
<u>LW3A-CON-A</u>	\$13.00	Ever Elettronica drive/motor power connector, replacement. For use with Ever Elettronica LW3A9030N2A1-00 microstepping drive.	<u>PDF</u>	<u>LW3A9030N2A1-00</u>
<u>LW3A-CON-B</u>	\$26.00	Ever Elettronica control signal connector, replacement. For use with Ever Elettronica LW3A9030N2A1-00 microstepping drive.	<u>PDF</u>	<u>LW3A9030N2A1-00</u>



EVER-PGM-1



EVER-PGM-1 connection to drive



EVER-PGM-2



LW4D3KIT-C0



LW4D3KIT-050



LW3D-CON-A



LW3D-CON-B



LW3A-CON-A



LW3A-CON-B



Stepping Drive Accessories

Ever Studio Drive Software

Ever Studio is a Windows PC software tool for the configuration of Ever's LW4D and LW3A series stepper drives. The software allows easy modification of drive parameters. Ever Studio allows more flexibility in configuring a motor than DIP switches. For example, LW3A has 6 DIP switch options for Step Angle, but Ever Studio can set the drive for many other microstep settings. Ever Studio also allows jogging/indexing of LW4D and has a built-in oscilloscope to help with tuning and debugging the LW4D.

System requirements:

- CPU: Intel i3 or better
- Operating System: Windows 7/8/8.1/10/11
- Memory: 512MB over the Windows OS requirement
- Hard Disk: 50MB free space
- Communications Interface: PC's USB to the drive's serial service interface (using [EVER-PGM-1](#) or [EVER-PGM-2](#) cable)



Ever Studio

Ever Stepper Drive Software			
Part Number	Price	Description	Use With
EVER-STUDIO	Free	Ever Elettronica Windows configuration software, free download only. For use with Ever Elettronica stepper drives with service interface port. Requires PC USB port.	LW4D3070N21-00 LW3A9030N2A1-00

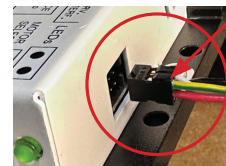
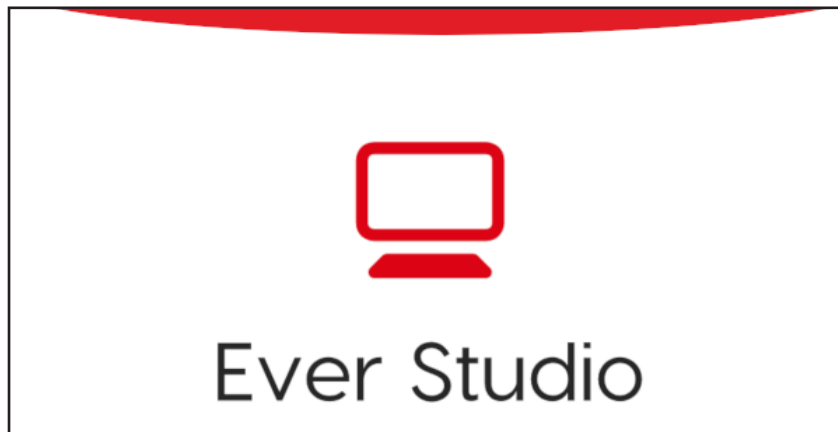

ATTENTION!!!
Correct insertion direction of the CN6: TAB UP.

