



iX7NH Series Servo Systems

Drive features

- Power: 400W–3.5 kW three-phase 230VAC
400W–750W single-phase 230VAC capable
400W 110VAC capable
- Fully digital control with up to 1kHz velocity loop response
- Easy setup and diagnostics with Drive CM PC-based software
- Field upgradeable firmware ensures the drive can always be upgraded to the latest operating system
- Capable of both EtherCAT® and Modbus TCP control. Uses XBF-PN04B/ XBF-PN08B EtherCAT® PLC modules for EtherCAT® operation and final commissioning. For Modbus TCP operation and final commissioning, use any Modbus TCP Client (Productivity, BRX, Click, etc.).
- Command options over EtherCAT® control and Modbus TCP include:

Command Option	EtherCAT® Control	Modbus TCP Control
Position Mode (PP)	✓	✓
Homing Mode (HM)	✓	✓
Velocity Mode (PV)	✓	✓
Torque Mode (PT)	✓	✓
Cyclic Synchronous Position Mode (CSP)	✓	
Cyclic Synchronous Velocity Mode (CSV)	✓	
Cyclic Synchronous Torque Mode (CST)	✓	

- ±10V Analog Torque Limit (not torque control)
- The 1 kHz bandwidth allows for high-level automatic tuning. Several modes of tuning are available including Off-Line Auto Tuning (the drive initiates its own move commands while Auto tuning), On-Line Auto Tuning (an external controller sends the move commands while the drive Auto tunes), and Manual Tuning (all tuning values are adjusted by the user).
- (6) Optically isolated configurable digital inputs and (3) user configurable outputs, (1) torque limit analog input. Two configurable analog outputs for monitoring various servo parameters (actual speed, torque, current, position, etc.)
- Advanced Scope feature that can monitor a variety of command and status signals, including output speed, torque, power, etc.

Tuning Technology

The iX7NH drive closes the loop on current, velocity, and position (depending on control mode selection). The 1kHz bandwidth in the drive assures precise speed and current control and easy tuning. Proportional gain, integral gain and compensation, feed forward compensation, command low pass filter, and four (4) notch filters for resonance suppression are available. Auto Tuning has been greatly improved and can tune motors up to 20:1 inertia mismatch.

There is an inertia estimation function that analyzes the motor and load to measure how much inertia is coupled to the motor.

The drive has several tuning methods available:

- Online Auto Tuning—the drive can either tune the load live while an external controller moves the load to different positions or using the drive's internal tuning motion profile.
- Offline Auto Tuning—the drive tunes the load using the drive's internal tuning motion profile.
- Manual Tuning—all parameters are available to give power users the ultimate flexibility to tune their systems.

Control Modes

When connected to an EtherCAT® Master, the iX7NH drive can run in Cyclic Synchronous Modes (Position, Velocity, Torque) where the Master controller sends an updated setpoint every EtherCAT® cycle (~1millisecond). In these modes, the upper controller plans the motion path.

The drive can also work in Profile Modes (Position, Velocity, Torque) where the Master Controller sends one setpoint for each move. In these cases, the drive's accel, decel, and max speed settings determine the motion path planning. The drive also has 21 different homing modes to accommodate most applications.

When connected to a Modbus TCP client, the drive can operate in Profile Modes (Position, Velocity, and Torque) and in Homing Mode. Because Modbus TCP is not deterministic, servos controlled by ModTCP typically aren't operated in Cyclic Synchronous modes.

EtherCAT®
Modbus TCP



- Future proof your system - use Modbus TCP now and convert to EtherCAT® control in the future.

Motor features

- Low and Medium inertia motors available:
 - Low: 100W, 200W, 400W, 750W, 1kW, and 1.5 kW; @5000rpm
 - Medium: 1.6 kW, 2.2 kW, and 3.5 kW; @3000rpm
- Permanent magnet 3-phase synchronous motor
- Keyed drive shafts support clamp-on style couplings or key-style couplings
- Integrated multi-turn absolute encoder with 19-bit resolution (524,288 pulses per revolution)
- Optional 24 VDC spring-set holding brakes (AMK2 and DMK2 motors)
- Standard hook-up cables for motor power, encoder, and brake (separate brake cable for FBL/FCL brake motors)
- Motor cables available in standard or flex-rated lengths of 3, 5, 10, and 20m
- Standard 20-pin DIN-rail mounted break-out kit for the drive's CN1 connector (with screw terminal connections), or 20-pin cables with flying leads

Note: These parts available for sale to North American locations only.

Optional Holding Brake

Each servo motor can be ordered with an optional 24VDC spring-set holding brake that holds the motor in place when power is removed.

LS Electric MSS Series In-Line Planetary Precision Gearboxes for Servo Motors

Need more torque from the motor? Have an inertia balancing issue in your design? The LS Electric MSS series gearboxes easily mate to FBL/FCL/FE/FF motors. Everything you need for mounting is included!



- Three gear ratios available (5:1, 10:1, 20:1)
- Mounting hardware included for attaching to FBL/FCL/FE/FF motors.
- Industry-standard mounting dimensions
- Thread-in mounting style
- Very low backlash: 7 arc-min single stage (5:1 and 10:1 ratios), 9 arc-min two-stage (20:1 ratios*).
- 1-year warranty

LS ELECTRIC

iX7NH Series Servo Systems

Servo drive overview

DC Bus Charge LED

Visual indication of the drive's DC bus voltage level. Do not work on the drive until the Charge LED is OFF.

Motor Power Terminal

Incoming single or three phase 200-230 VAC (-15% to +10%, 50/60Hz)

DC Reactor Connectors

Regenerative Resistor Terminal

Connection for optional external braking resistor

Control Power Terminal

Incoming single phase 200-230 VAC (-15% to +10%, 50/60Hz)

Motor Output Terminal

Output power to the servo motor. LS motor power cables available in 3, 5, 10, and 20 meter lengths in standard and flexing cables.

Model Number

Clearly displayed on bottom of drive face for easy identification.

LED Display

The 5-digit display is used to indicate servo status and alarm.

2 Rotary DIPswitch

Sets EtherCAT® Node ID from 0 to 97. Setting to 99 enables Modbus TCP with built-in webserver, while setting to 98 enables Modbus TCP w/o webserver.*

Analog Connector

4-pin analog monitoring connector (two +/- 10V analog outputs). See L7P-CON-F and L7P-CON-G for optional connectors.

Status LED

Indicates current state of EtherCAT® communication.

USB Connector

Used by Drive CM software for servo configuration. Connect with a standard USB A to USB mini-B cable (SV2-PGM-USB15, MOSAIC-CSU, or similar). Use USB OTG adapter cable (USB A Female to Mini USB B) if needed)

Firmware Upgrade: Use Drive CM software or attach a USB thumb drive with the new FW and update using USB On the Go (no PC required). See the UM for details.

EtherCAT® Com Ports

(ECAT IN, ECAT OUT). Use ECAT IN port (only) if using Modbus TCP.

Safe Torque Off Connector (STO)

Input/Output Connector (I/O)

20-pin CN1 connector for drive I/O. Signals include high speed pulse inputs, 6 digital inputs, 3 digital outputs, 1 analog input (torque limit), and scalable encoder output.

Encoder Connector

14-pin CN2 connector for the motor encoder. LS Encoder cables available in 3, 5, 10, and 20 meter lengths in standard and flexing cables.

* Node 98 functionality available in firmware 1.15 and above.

The LS Electric iX7NH servo drives are fully digital and include over 300 parameters to configure the drive for almost any application. For convenience, the parameters are grouped into several categories including:

- Basic parameters
- Gain parameters
- I/O parameters
- Velocity parameters
- Misc. parameters
- Monitor parameters

All parameters have commonly used default values which allow you to operate the iX7NH drive "out-of-the-box". The drive auto-detects the LS servo motor (through the serial encoder) and sets up the default gains and limits based on the connected motor.

The drive can still be easily configured to your specific application, however. The Drive CM configuration software has a built-in Setup Wizard that will guide you through all the basic setup parameters. The Setup Wizard will quickly and easily get your application started – from setting up the I/O to determining the appropriate homing sequence. When using ModTCP (Node 99) drive configuration can also be accomplished via a built-in webserver. This function can be disabled by setting Node ID to 98*.

Using XGB XBF-PN04B or XBF-PN08B EtherCAT® motion modules, you can also configure your drive from the XG5000 interface. See the Interactive PLC Guide for videos on how to commission and program the PLC/servo system.

After configuration is complete, the Auto Tune features of the drive will get your application tuned for optimal responsiveness and performance.



L7P/iX7NH AC Servo Systems

Servo motor overview

Encoder Connector

9-pin watertight connector for the 19-bit serial encoder. The encoder transmits motor/encoder identification information to the drive at power-up and it sends position feedback during operation.

Brake Power Connector

2-pin watertight connector available on FBL/FCL brake motors only. The 24VDC brake is located between the motor coils and the encoder. Motors ending in AMK2 and DMK2 have brakes. The brakes must have 24VDC applied to them before the motor is set in motion.

Low Inertia Motors

Low inertia designs (AMK series) result in high responsiveness at high speeds for lighter loads.

- 100–100W motors available
- 60 and 80 mm flanges

FBL/FCL Series Motor

Motor Power Connector

4-pin watertight connector for motor power (U, V, W, and ground)



IP67 Housing



Keyed Shafts

FBL and FCL motors are supplied with extra-large keyways, and slightly oversized keys which may need to be "fitted" into the keyway for performance and longevity. Clamp or compression couplings (without key) are recommended.

- 100W 14mm diameter shaft
- 200W 14mm diameter shaft
- 400W 14mm diameter shaft
- 750W 19mm diameter shaft
- 1000W 19mm diameter shaft

All LS Electric FBL/FCL/FE/FF motors have keyed shafts for use with servo-grade clamp or compression couplings (recommended) or servo-grade keyed couplings. Some sanding/filing of the key may be required before pressing into the keyway. Do not modify the shaft/keyway.

Encoder Connector

17-pin watertight connector for the 19-bit serial encoder. The encoder transmits motor/encoder identification information to the drive at power-up and it sends position feedback during operation.

Low and Medium Inertia Motors

Low inertia designs (AMK series) result in high responsiveness at high speeds for lighter loads.

- 1500W motors with 130mm flanges available

Medium inertia designs (DMK series) result in high responsiveness at moderate speeds for heavier loads.

- 1600–7500W motors available
- 130 and 180 mm flanges

FE/FF Series Motor

Motor Power Connector

4-pin watertight connector for motor power (U, V, W, and ground). For brake models, also supports brake wiring.



IP65 Housing

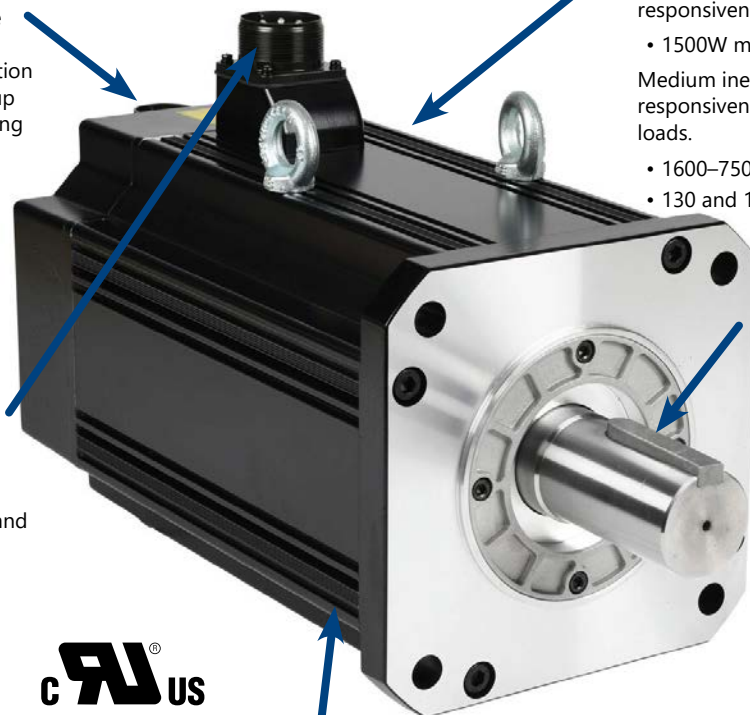

Keyed Shafts

FE and FF motors are supplied with extra-large keyways, and slightly oversized keys which may need to be "fitted" into the keyway for performance and longevity. Clamp or compression couplings (without key) are recommended.

- 900W 19mm diameter shaft
- 1500W 19mm diameter shaft
- 1600W 22mm diameter shaft
- 2200W 24mm diameter shaft
- 3500W 35mm diameter shaft
- 5500W 35mm diameter shaft
- 7500W 42mm diameter shaft



LS Electric AC Servo Systems

Drive Software

Drive CM Configuration Software

Drive CM is an optional free downloadable configuration software package for LS Electric servo drives. A PC may be directly connected to the servo drive via any standard USB-A to USB mini-B cable (SV2-PGM-USB15 or SV2-PGM-USB30 recommended).

Features

- Easy-to-use setup wizard guides you through the most common setup functions.
- Digital I/O / Jog Control allows the user to operate the servo system from the PC. This allows the servo to perform some basic motion and check the I/O during startup.
- Parameter Object editor for setting up all drive parameters.
- Tune and check the servo response in real-time using the scope feature.
- Upload and download the drive configuration. Save the drive configuration as a file for backup or future use.
- Edit the drive configuration.
- View all drive faults.
- View drive variable trends in real-time.
- (L7P/L7C series only) Set up 64 internal Indexes (point-to-point moves) that can be triggered by digital inputs or serial communications. Indexes can repeat and can initiate another Index when one move completes.

Download

Download the Drive CM software from AutomationDirect's LS Electric support page:

<https://support.automationdirect.com/products/lselectric.html>

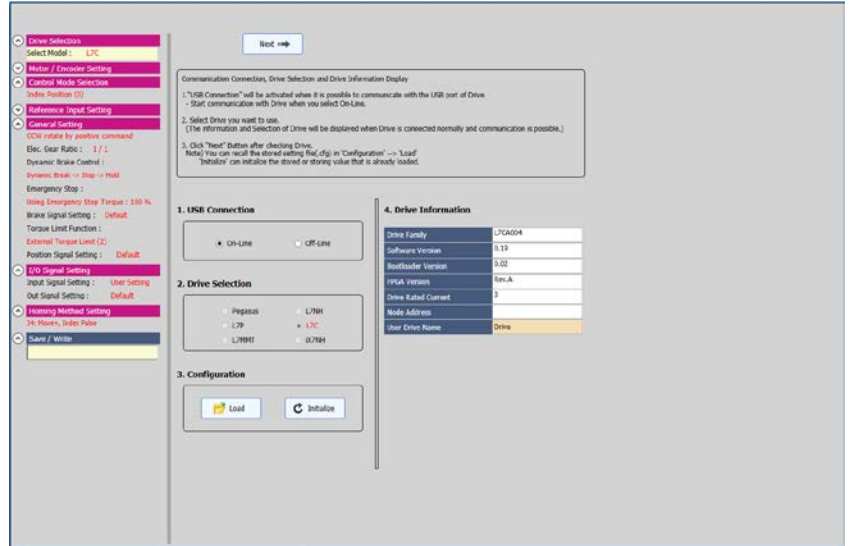

Setup Wizard Screen

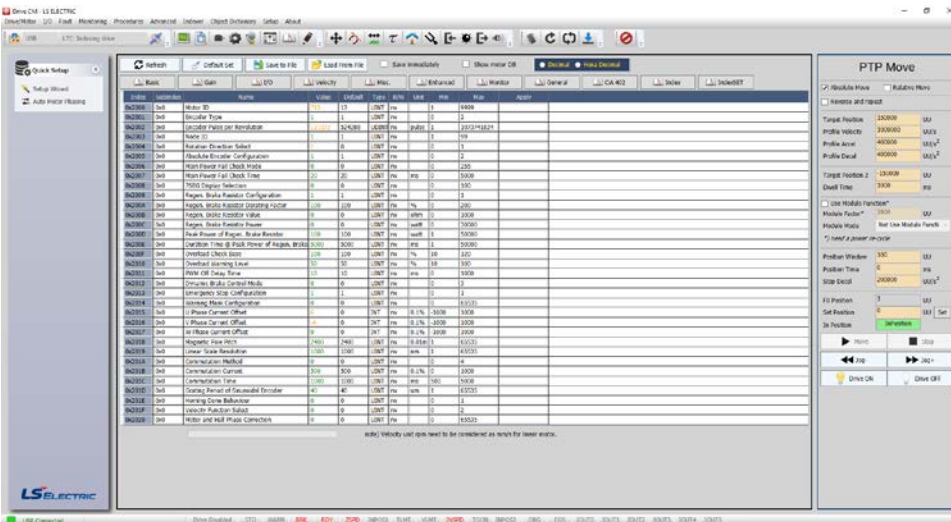

Drive CM Software Interface

Parameter Object Editor

The Drive CM configuration tool logically organizes all servo drive object parameters for viewing and editing using the Object Dictionary screen. Each parameter has a factory default that usually allows the servo to run "out-of-the-box".

The parameters can be easily changed with available setting ranges displayed. Tuning modes and parameters can also be changed using Drive CM. After the parameters have been defined, the complete setup can be stored and archived. Drive configurations can be uploaded, edited, saved, and downloaded as often as necessary.

Using the Drive CM software you can also configure and commission your drive without having to be connected to the master controller.



LS Electric AC Servo Systems

Drive Software, *continued*

Digital I/O, Jog Control, and Scope

The Digital I/O / Jog Control screen allows the user to operate the servo system from the PC. This is a great aid during start-up to allow the servo to perform some basic motion and to check the I/O.

Drive CM also includes a powerful scope function that allows the user to have as many as four channels of data displayed simultaneously. Each channel has a drop-down table to select the data to be displayed. The scope has the ability to save traces to a file and load those traces for offline review/analysis. This function is a valuable tool for tuning LS Electric servo drives.



Jog Control / Scope Screen

General Setup Screen

Alarm History Screen

Indexer Setting Screen (L7P/L7C series only)

Object Dictionary Screen

Drive Software, *continued*

Modbus TCP Webserver (iX7NH Series)

When using Modbus TCP as the control mode, the drive can generate a built-in webserver to accomplish most of the tasks Drive CM is used for (configuration, jog, fault monitoring/reset, firmware upgrade, etc.). Setting the drive DIP switches to Node 99 enables Modbus TCP and enables the webserver. If your IT security policy does not allow web servers on your network, the webserver can be disabled by using Node 98 (enables Modbus TCP with no webserver). The Node 98 functionality is available in firmware versions 1.15 and above.

The screenshot displays the webserver interface for an LS Electric AC Servo System. It is divided into several sections:

- Servo Drive:** Shows configuration parameters for the drive unit, including Device Name (iX7NHA004), Rated Current (3 Arms), F/W Version (313.0), FPGA Version (0.24), and Boot Version (0.03).
- Servo Motor/Encoder:** Shows configuration parameters for the motor and encoder, including Motor ID (715), Rated Torque (0.681 Nm), Rated Speed (3000 rpm), Maximum Speed (5000 rpm), Encoder Type (4), and Encoder Resolution (524288 ppr).
- Manual Jog:** Provides controls for manual operation, including a Speed input (500 rpm/mm/s), Smoothing parameters (Accel Time: 200 ms, Decel Time: 200 ms, S-curve Time: 0 ms), Servo-Lock checkbox, and FB Speed/Position inputs (0 rpm/mm/s, 0 UU). Control buttons include CCW, CW, STOP, SVON, and SVOFF.
- Life Diagnosis:** Displays operational statistics such as Accumulated Usage Time (9days 23h:45m:9s), Charge Relay Operation Count (147), DB Relay Operation Count (147), Capacitor Life Time (0.34%), and Fan Life Time (0%).
- Navigation and Status:** A left sidebar contains a menu for Servo Information, Motor/Encoder, Fault, Monitoring, Procedure, Object Dictionary, and Setup. A status bar at the bottom shows Drive Enable (ON), STO (OFF), ALM (OFF), and various fault codes (BRR, RDY, ZSPD, INPOS1, TLMT, VLMT, INSPD, TGON, INPOS2, WARN).

Example Webserver Screen

How to select and apply iX7NH systems

The primary purpose of the AC servo system is to precisely control the motion of the load. The most fundamental considerations in selecting the servo system are “reflected” load inertia, servo system maximum speed requirement, servo system continuous torque requirement, and servo system peak torque requirement. In a retrofit application, select the largest torque servo system that most closely matches these parameters for the system being replaced. In a new application, these parameters should be determined through calculation and/or

measurement. The Drive CM software has the ability to measure the load (reflected) inertia and accurately measure the motor torque output.

AutomationDirect has teamed with Copperhill Technologies to provide free servo-sizing software. “VisualSizer-SureServo” software will assist in determining the correct motor and drive for your application by calculating the reflected load inertia and required speed and torque based on the load configuration. “VisualSizer-SureServo” software can be downloaded from <https://support.automationdirect.com/products/lselectric.html>.

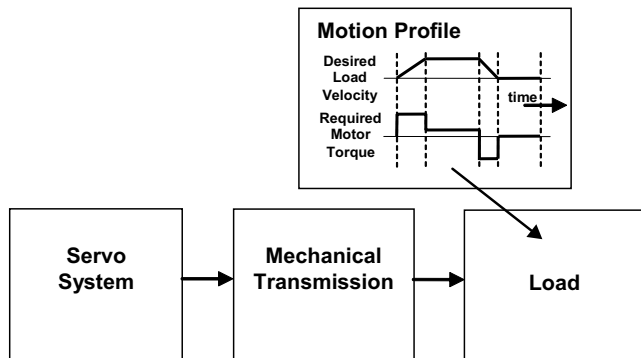

1. “Reflected” load inertia

The inertia of everything attached to the servo motor driveshaft needs to be considered and the total “reflected” inertia needs to be determined. This means that all elements of any mechanical transmission and load inertia need to be translated into an equivalent inertia as if attached directly to the motor driveshaft. The ratio of “reflected” load inertia to motor inertia needs to be carefully considered when selecting the servo system.

In general, applications that need high response or bandwidth

will benefit from keeping the ratio of load inertia to motor inertia as low as possible and ideally under 10:1. iX7NH Auto Tuning will still tune a system with very high response, up to 20:1 inertia mismatch. Higher system ratios can be implemented, but corresponding lower bandwidth or responsiveness must be accepted. The servo response including the attached load inertia is determined by the servo tuning. The iX7NH servo systems may be tuned automatically by the software/drive or manually by the user.

2. Torque and speed

With knowledge of the motion profile and any mechanical transmission between the motor and load, calculations can be made to determine the required servo motor continuous torque, peak torque, and maximum motor speed. The required amount of continuous torque must fall inside the continuous operating region of the system torque-speed curve (you can check the continuous torque at the average speed of the motion profile). The required amount of peak torque must also fall within the servo system’s intermittent operating region of the system torque-speed curve (you need to check this value at the required maximum speed or torque). If you have an iX7NH system, these values are easily captured and recorded with the Scope feature built into the Drive CM software. If you are designing the system from scratch, use VisualSizer to define the system and calculate expected inertia and required power.

Compare the application’s Continuous and Intermittent torque requirements to the torque-speed curves found in Chapter 11.3 of the iX7NH User Manual or in the system torque charts found on “iX7NH AC servo drive, motor, and cable combinations” on page tMNC-228.

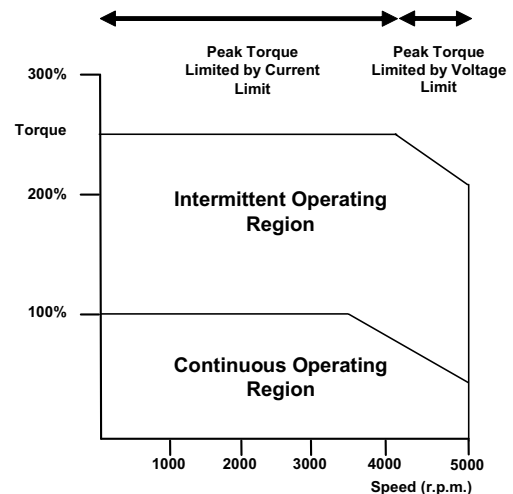

Application tip - coupling considerations

The LS Electric FBL/FCL motors have keyed shafts that can be used with keyed couplings or with clamp-on or compression style couplings. For standard keyed couplings, the servo key must be "fitted" into the keyway for optimum performance and longevity. Some minor filing and pressing of the key may be required. "Servo-grade" clamp-on or compression style couplings

are usually the best choice when you consider stiffness, torque rating, and inertia. Higher stiffness (lb-in/radian) is needed for better response but there is a trade-off between stiffness and the added inertia of the coupling. Concerning the torque rating of the coupling, use a safety factor of 1.25 over the servo's **peak** torque requirement of your application.

[Click here for Available Couplings](#)

Mechanical transmissions

Common mechanical transmissions include leadscrews, rack & pinion mechanisms, conveyors, gears, and timing belts. The use of leadscrew, rack & pinion, or conveyor are common ways to translate the rotary motion of the servo motor into linear motion of the load. Matched gearboxes are available from LS Electric that will work with the LS servo motors. Each gearbox is selected to accept the 300% maximum available torque that could be generated by the motor. Gearboxes are available in 5:1, 10:1, and 20:1 ratios. The use of a speed reducer such as a gearbox or timing belt can be very beneficial as follows:

1. Reduction of reflected load inertia

As a general rule, keep the reflected load inertia as low as possible while using the full range of servo speed. The LS Electric motors can rotate at a rated speed of 2000 or 3000 rpm (rated torque at rated speed). Their max speed (slightly less available torque) is 3000 or 5000 rpm. See the speed-torque curves for more information.

Example: A gearbox reduces the motor's required torque by a factor of the gear ratio, and reduces the reflected load inertia by a factor of the gear ratio squared. A 10:1 gearbox reduces output speed to 1/10, increases output torque 10 times, and decreases reflected inertia to 1/100.

However, when investigating the effect of different speed reduction ratios DO NOT forget to include the added inertia of couplings, gearbox, or timing belt pulleys. These added inertias can be significant, and can negate any inertia reduction due to the speed reduction.

[Here is a link to our Timing Belts and Pulleys](#)

2. Low speed and high torque applications

If the application requires low speed and high torque then it is common to introduce a speed reducer so that the servo system can operate over more of the available speed range. This could also have the added benefit of reducing the servo motor torque requirement which could allow you to use a smaller and lower cost servo system. Additional benefits are also possible with reduction in reflected inertia, increased number of motor encoder counts at the load, and increased ability to reject load disturbances due to mechanical advantage of the speed reducer.

3. Space limitations and motor orientation

LS Electric servo motors can be mounted in any orientation, but the shaft seal should not be immersed in oil (open-frame gearbox, etc.). Reducers can possibly allow the use of a smaller motor or allow the motor to be repositioned.



Motor	Brake Motor	LS Electric MSS Planetary In-Line Gearboxes		
		5:1 Gearbox	10:1 Gearbox	20:1 Gearbox
APMC-FBL01AMK-AD	APMC-FBL01AMK2-AD	96200004	96200005	96200103
APMC-FBL02AMK-AD	APMC-FBL02AMK2-AD			
APMC-FBL04AMK-AD	APMC-FBL04AMK2-AD			
APMC-FCL08AMK-AD	APMC-FCL08AMK2-AD	96200007	96200008	96200257
APMC-FCL10AMK-AD	APMC-FCL10AMK2-AD			
APM-FE15AMK-AD	APM-FE15AMK2-AD	96200373	96200378	96200393
APM-FE16DMK-AD	APM-FE16DMK2-AD	96200459	96200464	96200479
APM-FE22DMK-AD	APM-FE22DMK2-AD	96200010	96200011	96200445
APM-FF35DMK-AD	APM-FF35DMK2-AD	96200013	96200014	96200701

Ordering Guide

The following pages are your ordering guide for LS Electric iX7NH servo systems. Each system has a torque-speed curve included for reference. This is the fundamental information that you need to select the servo motor and matching drive for your application.

Each system needs:

- Drive and Motor
- Motor Power Cable
- Motor Encoder Cable
- I/O connections (either a 20-pin CN1 cable+terminals kit or a 20-pin flying lead cable (user provides terminal blocks))
- FBL/FCL brake motors require a brake cable. FE/FF brake motors have brake wiring included in the power cable.
- STO cable (APCS-STOxxA-AD) or STO bypass plug (APCS-CN6K-AD). An STO bypass plug is included with each drive.

iX7NH series drives and motors part numbering system

Drives

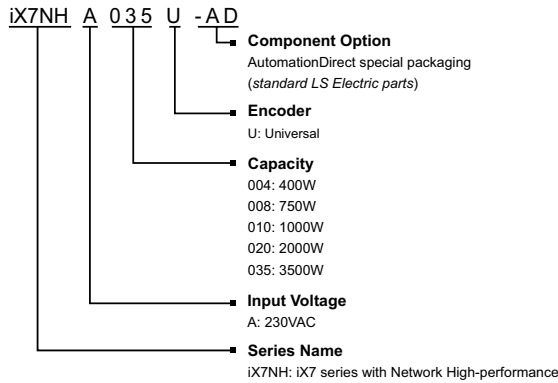

Motors

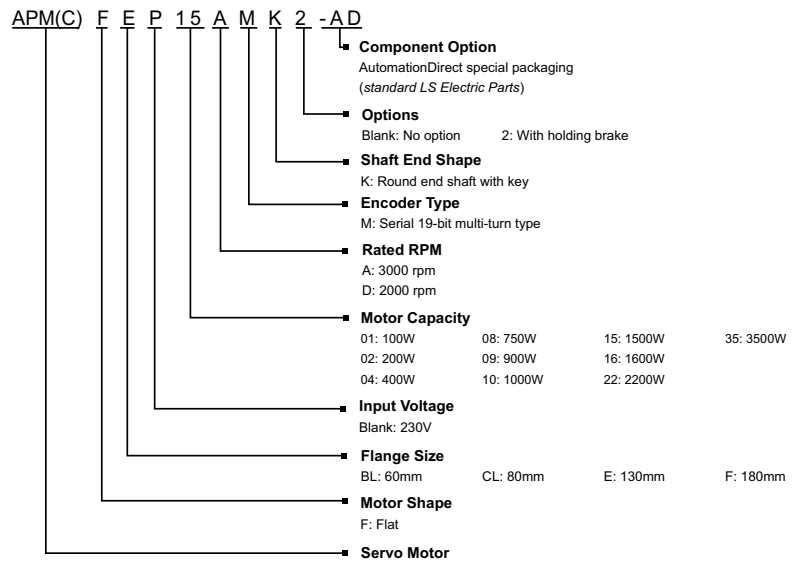

Example of what you will need to build a complete servo system:

Servo Drive



Servo Motor



Motor Power Cable



Motor Encoder Cable



I/O Interface



**Completed motor assembly
(with optional gearbox)**



NOTE: AMPC-FBL/FCL brake equipped motors will also require a separate brake power cable.



NOTE: Required programming software (free download). Use a standard USB-A to USB mini-B cable for connectivity (SV2-PGM-USB15, MOSAIC-CSU, or equivalent)



NOTE: If you need a gear box for your configuration, reference the gearbox chart on the previous page. Ratios of 5:1, 10:1, and 20:1 are available for each motor.





iX7NH Series Servo Systems

Torque to iX7NH System Quick Reference

Input Voltage	System Rated Torque (N·m)	System Maximum Torque (N·m)	Suggested Servo Motor	Required Servo Drive
120/230 VAC	0.32	0.96	APMC-FBL01AMK-AD	IX7NHA004U-AD
			APMC-FBL01AMK2-AD	
	0.64	1.91	APMC-FBL02AMK-AD	
			APMC-FBL02AMK2-AD	
	1.27	3.82	APMC-FBL04AMK-AD	
			APMC-FBL04AMK2-AD	
230VAC	2.39	7.16	APMC-FCL08AMK-AD	IX7NHA008U-AD
			APMC-FCL08AMK2-AD	
	3.10	9.55	APMC-FCL10AMK-AD	IX7NHA010U-AD
			APMC-FCL10AMK2-AD	
	4.77	14.32	APM-FE15AMK-AD	IX7NHA020U-AD
			APM-FE15AMK2-AD	
	7.63	22.92	APM-FE16DMK-AD	
			APM-FE16DMK2-AD	
	10.5	31.51	APM-FE22DMK-AD	IX7NHA035U-AD
			APM-FE22DMK2-AD	
	16.7	50.1	APM-FF35DMK-AD	
			APM-FF35DMK2-AD	

For information on using single-phase supply, please see "Drive Derating for Single-phase Usage" on page tMNC-232



iX7NH Series Servo Systems

iX7NH AC servo drive, motor, and cable combinations

xx = Cable length in meters
 BN/EN/PN = Standard cable (not continuous flex)
 BF/EF/PF = Flex-rated cable

AMK/DMK motors = no brake
 AMK2/DMK2 motors = mechanical holding brake

230V FBL/FCL Motor Systems

Type	System Torque Chart	iX7NH Drive	APM/APMC Motor	Power Cable	Encoder Cable	Brake Cable	I/O Cable and Breakout
100W Low Inertia System		IX7NHA004U-AD	APMC-FBL01AMK-AD	APCS-PNxxxLSX-AD	APCS-ENxxxES1-AD	n/a	APCS-L7NCN1Txx-AD or APCS-CN10xA-AD
				APCS-PFxxxLSX-AD	APCS-EFxxxES1-AD		
			APMC-FBL01AMK2-AD	APCS-PNxxxLSX-AD	APCS-ENxxxES1-AD	APCS-BNxxQS-AD	
				APCS-PFxxxLSX-AD	APCS-EFxxxES1-AD	APCS-BFxxQS-AD	
200W Low Inertia System		IX7NHA004U-AD	APMC-FBL02AMK-AD	APCS-PNxxxLSX-AD	APCS-ENxxxES1-AD	n/a	
				APCS-PFxxxLSX-AD	APCS-EFxxxES1-AD		
			APMC-FBL02AMK2-AD	APCS-PNxxxLSX-AD	APCS-ENxxxES1-AD	APCS-BNxxQS-AD	
				APCS-PFxxxLSX-AD	APCS-EFxxxES1-AD	APCS-BFxxQS-AD	
400W Low Inertia System		IX7NHA004U-AD	APMC-FBL04AMK-AD	APCS-PNxxxLSX-AD	APCS-ENxxxES1-AD	n/a	
				APCS-PFxxxLSX-AD	APCS-EFxxxES1-AD		
			APMC-FBL04AMK2-AD	APCS-PNxxxLSX-AD	APCS-ENxxxES1-AD	APCS-BNxxQS-AD	
				APCS-PFxxxLSX-AD	APCS-EFxxxES1-AD	APCS-BFxxQS-AD	
750W Low Inertia System		IX7NHA008U-AD	APMC-FCL08AMK-AD	APCS-PNxxxLSX-AD	APCS-ENxxxES1-AD	n/a	
				APCS-PFxxxLSX-AD	APCS-EFxxxES1-AD		
			APMC-FCL08AMK2-AD	APCS-PNxxxLSX-AD	APCS-ENxxxES1-AD	APCS-BNxxQS-AD	
				APCS-PFxxxLSX-AD	APCS-EFxxxES1-AD	APCS-BFxxQS-AD	



iX7NH Series Servo Systems

iX7NH AC servo drive, motor, and cable combinations, *continued*

xx = Cable length in meters

BN, EN, or PN = Standard cable (not continuous flex)

BF, EF, or PF = Flex-rated cable

AMK/DMK motors = no brake

AMK2/DMK2 motors = mechanical holding brake

Type	System Torque Chart	iX7NH Drive	APMC Motor	Power Cable	Encoder Cable	Brake Cable	I/O Cable and Breakout
1.0k W Low Inertia System		IX7NHA010U-AD*	APMC-FCL10AMK-AD	APCS-PNxxxLSX-AD	APCS-ENxxxES1-AD	n/a	APCS-L7NCN1Txx-AD or APCS-CN10xA-AD
				APCS-PFxxxLSX-AD	APCS-EFxxxES1-AD		
			APMC-FCL10AMK2-AD	APCS-PNxxxLSX-AD	APCS-ENxxxES1-AD	APCS-BNxxQS-AD	
				APCS-PFxxxLSX-AD	APCS-EFxxxES1-AD	APCS-BFxxQS-AD	

* Note - For 1kW drive single-phase supply, derate motor max torque to 200%, or upsize the drive to iX7NHA020U-AD for the torque curves in the graph.

230V FE Motor Systems

Type	System Torque Chart	iX7NH Drive	APM/APMC Motor	Power Cable**	Encoder Cable	I/O Cable and Breakout
1.5 kW Low Inertia System		IX7NHA020U-AD***	APM-FE15AMK-AD	APCS-PNxxHSX1-AD	APCS-ENxxxDS1-AD	APCS-L7NCN1Txx-AD or APCS-CN10xA-AD
				APCS-PFxxHSX1-AD	APCS-EFxxxDS1-AD	
			APM-FE15AMK2-AD	APCS-PNxxNBX1-AD	APCS-ENxxxDS1-AD	
				APCS-PFxxNBX1-AD	APCS-EFxxxDS1-AD	
1.6 kW Medium Inertia System		IX7NHA020U-AD***	APM-FE16DMK-AD	APCS-PNxxHSX-AD	APCS-ENxxxDS1-AD	APCS-L7NCN1Txx-AD or APCS-CN10xA-AD
				APCS-PFxxHSX-AD	APCS-EFxxxDS1-AD	
			APM-FE16DMK2-AD	APCS-PNxxNBX-AD	APCS-ENxxxDS1-AD	
				APCS-PFxxNBX-AD	APCS-EFxxxDS1-AD	
2.2 kW Medium Inertia System		IX7NHA020U-AD***	APM-FE22DMK-AD	APCS-PNxxHSX-AD	APCS-ENxxxDS1-AD	APCS-L7NCN1Txx-AD or APCS-CN10xA-AD
				APCS-PFxxHSX-AD	APCS-EFxxxDS1-AD	
			APM-FE22DMK2-AD	APCS-PNxxNBX-AD	APCS-ENxxxDS1-AD	
				APCS-PFxxNBX-AD	APCS-EFxxxDS1-AD	

** Note - Power cables with "B" in the part number are combination power/brake cables, providing power for both the motor and the brake. A brake cable is not required.

*** Note - For single-phase supply, upsize the drive to iX7NHA035U-AD (2.2 kW motor max torque limited to 150%, 1.5/1.6 kW motors limited to 200% max motor torque).



iX7NH Series Servo Systems

iX7NH AC servo drive, motor, and cable combinations, *continued*

xx = Cable length in meters

BN, EN, or PN = Standard cable (not continuous flex)

BF, EF, or PF = Flex-rated cable

AMK/DMK motors = no brake

AMK2/DMK2 motors = mechanical holding brake

230V FF Motor Systems

Type	System Torque Chart	iX7NH Drive	APM/APMC Motor	Power Cable*	Encoder Cable	I/O Cable and Breakout
3.5 kW Medium Inertia System		IX7NHA035U-AD	APM-FF35DMK-AD	APCS-PNxxISX-AD	APCS-ENxxxDS1-AD	APCS-L7NCN1Txx-AD or APCS-CN10xA-AD
				APCS-PFxxISX-AD	APCS-EFxxxDS1-AD	
			APM-FF35DMK2-AD	APCS-PNxxPBX-AD	APCS-ENxxxDS1-AD	
				APCS-PFxxPBX-AD	APCS-EFxxxDS1-AD	

*Note - Power cables with "B" in the part number are combination power/brake cables, providing power for both the motor and the brake. A brake cable is not required.



iX7NH Series Servo Systems

i7XNH Servo drive specifications

i7XNH Servo Drive Specifications						
Model		IX7NHA004U-AD	IX7NHA008U-AD	IX7NHA010U-AD	IX7NHA020U-AD	IX7NHA035U-AD
Price		\$495.00	\$610.00	\$620.00	\$700.00	\$726.00
Drawing		PDF	PDF	PDF	PDF	PDF
Power	Input Power	One phase 100–120 VAC One phase 200–240 VAC	One phase 200–240 VAC	Three phase 200–230 VAC (-15 to +10%), 50–60Hz**		
		Three phase 200–230 VAC (-15 to +10%), 50–60Hz**				
	Rated Current [Amps]	3.0	5.2	6.75	13.5	16.0
	Peak Current [Amps]	10.5	18.2	20.25	40.5	48.0
Inrush Current		34A @ 240VAC		57A @ 240VAC		
Encoder Type		Quadrature (Incremental), BiSS-B, BiSS-C (Absolute, Incremental) Tamagawa Serial (Absolute, Incremental), EnDat 2.2, Sinusoidal, Analog Hall, SSI, Nikon, Panasonic				
Encoder Decimation Output		Differential Line Drive 3 channels AO, /AO, BO, /BO, ZO, /ZO up to 6.5 Mpps on 4x interpolation				
Control Performance	Speed Control Range	Maximum 1:5000				
	Frequency Response	Maximum 1kHz (for a 19-bit serial encoder)				
	Speed Variation Ratio	± 0.01 % or lower (when load changes between 0 and 100%), ± 0.1 % or lower (temperature 25±10°C)				
	Accel/Decel Time	Straight line acceleration/deceleration (0–10,000 ms) and/or S-curve (0–1000 ms)				
	Torque Control Repetition Accuracy	± 1% or less				
Recommended Breaker (UL 489)		15A (max)		30A (max)		
Recommended Fuse***		15A (max)		30A (max)		
SCCR Rating***		5kA				
EtherCAT® Specification	Communication Standard	FoE (Firmware download), EoE (parameter setting by UDP, Tuning, Secondary function, Parameter copy) CoE (IEC 61158 Type 12, IEC 61800-7 CiA 402 Drive Profile)				
	Physical Layer	100BASE-TX (IEEE802.3)				
	Connector	RJ45 x 2				
	Communication Distance	Distance between nodes 100m or less				
	DC (Distributed Clock)	Synchronization by DC (Distributed Clock) mode. Minimum DC cycle: 125µs				
	LED Display	L/A0 & L/A1 (Link Activity) LED for EtherCAT In & Out status				
Digital I/O Specifications	Digital Input	Input voltage range: 12–24 VDC, total 6 input channels (configurable) 15 different selectable functions for assignment. (*POT, *NOT, *HOME, *STOP, *PCON, *GAIN2, P_CL, N_CL, PROBE1, PROBE2, EMG, A_RST, SV_ON, LVSF1, LVSF2)				
	Digital Output	Service rating: 24VDC ± 10%, 120mA, 3 output channels are configurable 11 different selectable functions for assignment (*BRAKE, *ALARM, *READY, ZSPD, INPOS, TLMT, VLMT, INPOS2, INSPD, WARN, TGON)				
Analog I/O	Analog Input	Input voltage range: ±10V Function: analog torque limit (1 channel, not configurable)				
	Analog Output	12-bit resolution, ±10V output range, total 2 channels (configurable): able to selectively configure 25 types of output				
Continued on next page						

* Basic allocation signal.

** See Single-phase power input section on the following page for single phase considerations.

*** Use class CC or High Speed J (JHL series) current limiting fuses to prevent nuisance tripping and to increase panel SCCR rating.

iXNH Servo drive specifications, *continued*

iXNH Servo Drive Specifications, <i>continued</i>		
<i>Continued from previous page</i>		
<i>Model</i>	<i>All iX7NH Series Drives</i>	
<i>Safety Function</i>	2 Input Channels (STO1 and STO2), 1 Output Channel (EDM)	
USB Communication	<i>Function</i>	Firmware download, tuning, test drive, monitoring, parameter duplication
	<i>Communication Standard</i>	Complies with USB 2.0 Full Speed and OTG 2.0 standards.
	<i>Accessible Device</i>	PC or USB storage device
Internal Function	<i>Dynamic Braking</i>	Standard built-in brake (activated when the servo alarm goes off or when the servo is off)
	<i>Regenerative Braking</i>	Built-in by default
	<i>Display Function</i>	7-segment display (5 digits)
	<i>Self-setting Function</i>	Drive node address setting is possible using two rotary switches
	<i>Additional Function</i>	Gain tuning, alarm history, jog operation, home searching
	<i>Protection Function</i>	Overcurrent, overload, overheat, overvoltage, insufficient voltage, overspeed, abnormal state of encoder, position following error, current detecting error
Operation Environment	<i>Operating Temperature</i>	0–50 °C [32–122 °F]
	<i>Storage Temperature</i>	-20–65 °C [-4–149 °F]
	<i>Operating Humidity</i>	Under 80% relative humidity
	<i>Storage Humidity</i>	Under 90% relative humidity (non-condensing)
	<i>Environment</i>	Keep indoors, avoid corrosive/flammable gas or liquid
Approvals	cUL _{US} (E479434), CE, UKCA, KC	

Single-phase Power Input

Although designed with 3-phase AC input power in mind, some iX7NH systems are capable of supporting single-phase AC input power. With three phase AC supply, the iX7NH motor/drive combination supplies 300% rated maximum motor torque (see the instantaneous Operation Range in the torque-speed charts on previous pages). With single phase AC supply some ratings will have limited maximum/intermittent motor torque, and/or the next larger drive size will be required.

Drive Derating for Single-phase Usage		
3-phase Motor Rating	Drive to use with Single-phase Input	Motor Torque Derating for Single-phase Input
100W/200W/400W	iX7NHA004U-AD (400W)	No upsizing/derating required. Single phase and three phase input both produce 300% max torque
750W	iX7NHA008U-AD (1kW)	No upsizing/derating required. Single phase and three phase input both produce 300% max torque
1kW	iX7NHA010U-AD (1kW) or iX7NHA020U-AD (2kW)	2kW drive produces 300% max torque. The 1kW drive can be used, but the motor can only provide 200% max torque.
1.5 kW/1.6 kW	iX7NHA035U-AD (3.5 kW)	With single phase supply, this drive only produces 150% max motor torque with a 2.2 kW motor. 3.5kW drive produces 200% max torque with 1.5 kW and 1.6 kW motors.
2.2 kW		
3.5 kW	n/a	No single phase capability

iX7NH Drive Standard Installation

iX7NH Drive Installation Spacing

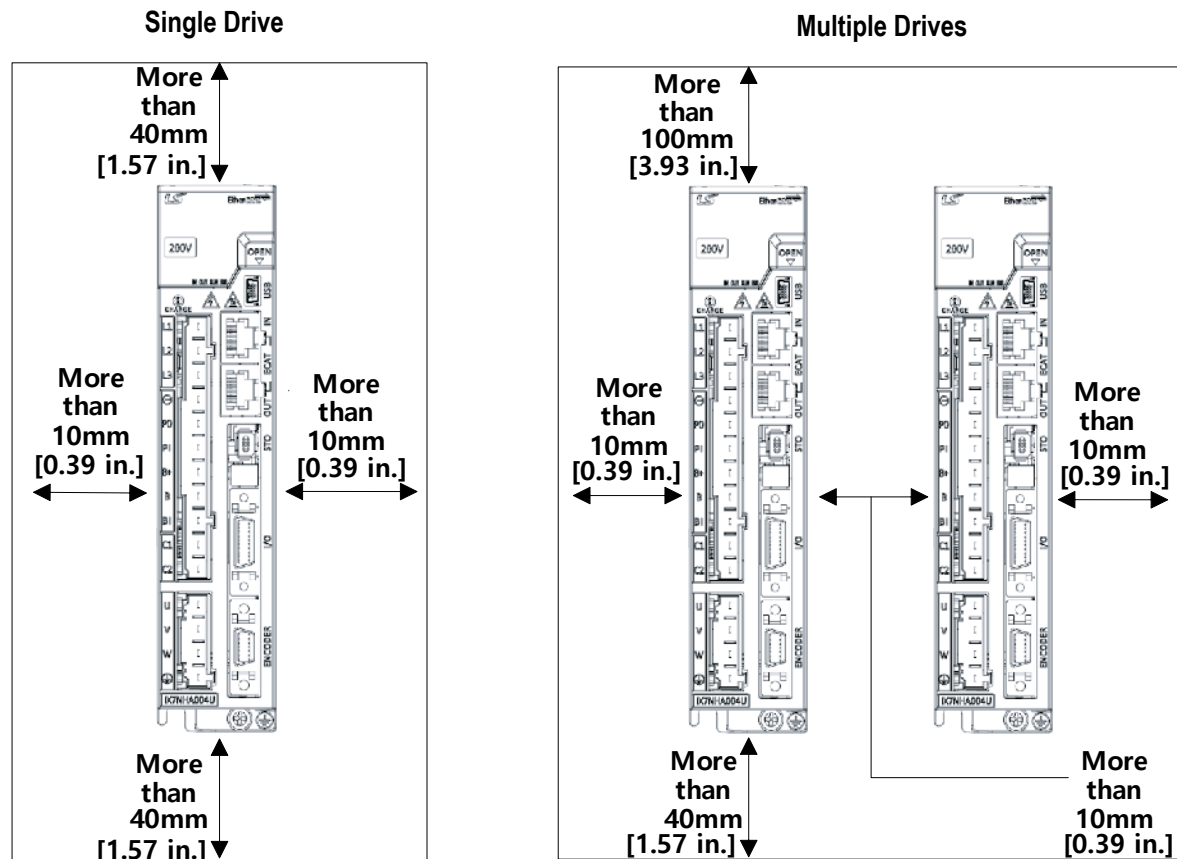

iX7NH Drive Installation Concerns:

- Install external regenerative resistors so that any heat generated does not affect the drive.
- Vertical installation only. For proper heat dissipation, ensure the back of the drive makes good contact with the subpanel.
- Protect the drive from metal chips and other falling debris during control panel assembly.
- Make sure that oil, water, or metal dust do not enter the drive.
- Protect the control panel by using an air purge system when installing it in any area where there are harmful gases or dust.

iX7NH Drive Wiring

iX7NH Power Supply Wiring



NOTE: Single-phase can use 2 of R, S, or T. See "Single-phase Power Input" on page tMNC-232 for more information.

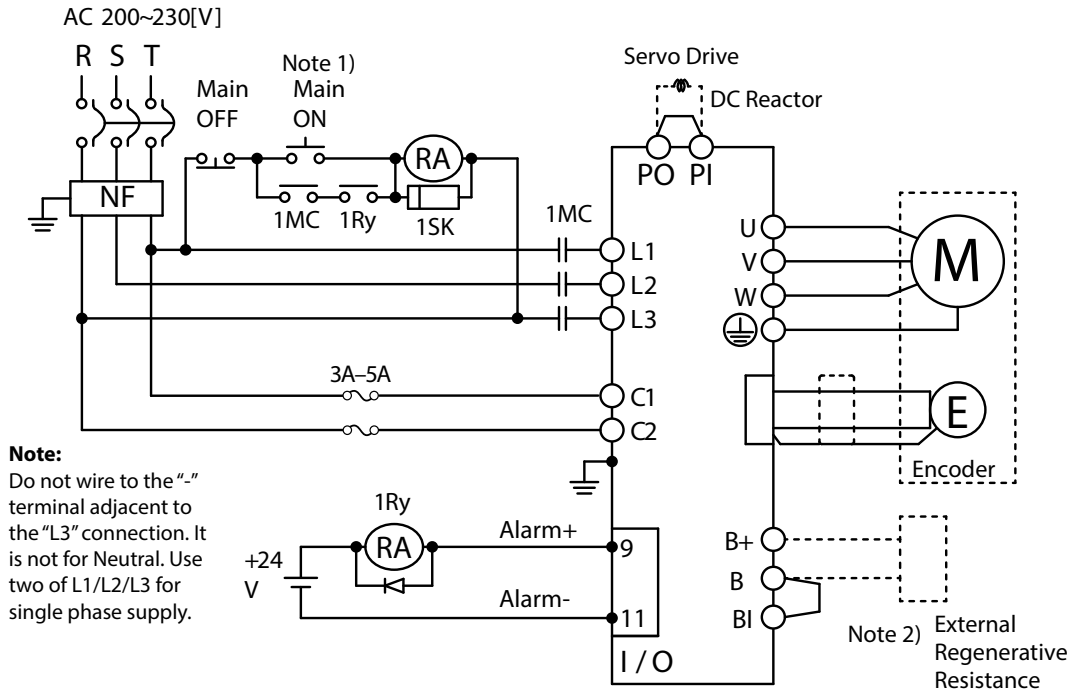

NOTE 1: About 2.5–3 seconds are required from main power supply to alarm signal output. Hold the main power on for 3 seconds until the alarm circuit ("1Ry") will latch main power ON.



NOTES 2 & 3: Remove the jumper for the internal resistor between B and BI, and connect the external resistor to the B+ and B pins. If an external regen resistor is required, see the available regen resistors under the Motion Control category at AutomationDirect.com (APCS-140R50-AD, APCS-300R30-AD, etc.).



L7P/iX7NH AC Servo Systems

60–80 mm Frame Motor Specifications

L7P/iX7NH 60–80 mm Frame Motor Specifications											
Model	APMC-FBL01AMK-AD	APMC-FBL02AMK-AD	APMC-FBL04AMK-AD	APMC-FCL08AMK-AD	APMC-FCL10AMK-AD	APMC-FBL01AMK2-AD	APMC-FBL02AMK2-AD	APMC-FBL04AMK2-AD	APMC-FCL08AMK2-AD	APMC-FCL10AMK2-AD	
Price	\$273.00	\$318.00	\$329.00	\$404.00	\$449.00	\$490.00	\$515.00	\$525.00	\$604.00	\$640.00	
Drawing	PDF	PDF	PDF	PDF	PDF	PDF	PDF	PDF	PDF	PDF	
Input Voltage	230VAC										
Drive Compatibility	L7P and iX7NH drives										
Integrated Brake	No					Yes					
Flange Size (mm)	60			80			60			80	
Rated Power [kW]	0.1	0.2	0.4	0.75	1	0.1	0.2	0.4	0.75	1	
Rated Torque [N·m] ^{Note 1}	0.32	0.64	1.27	2.39	3.18	0.32	0.64	1.27	2.39	3.18	
Max. Torque [N·m]	0.96	1.91	3.82	7.16	9.55	0.96	1.91	3.82	7.16	9.55	
Rated Speed [rpm]	3000										
Max. Speed [rpm]	5000										
Mechanical Time Constant [ms]	0.926	0.518	0.374	0.609	0.492	0.926	0.518	0.374	0.609	0.492	
Rated current [Amps] rms	0.95	1.45	2.6	5.02	5.83	0.95	1.45	2.6	5.02	5.83	
Max. Instantaneous Current [Amps] rms	2.85	4.35	7.8	15.07	17.5	2.85	4.35	7.8	15.07	17.5	
Rated Power Rate [kW/s]	11.09	27.6	27.07	45.09	62.08	11.09	27.6	27.07	45.09	62.08	
Electrical Time Constant [ms]	2.416	3.488	4.271	5.774	6.919	2.416	3.488	4.271	5.774	6.919	
Insulation Class	Class BE (CE, UL)										
Insulation Resistance	>10MΩ, 500VDC										
Insulation Strength	1.8 kVAC, 1 second										
Rotor Inertia [x10 ⁻⁴ kg m ²]	0.091	0.147	0.248	1.264	1.632	0.091	0.147	0.248	1.264	1.632	
Allowable Load Inertia Ratio	20 times motor inertia			15 times motor inertia			20 times motor inertia			15 times motor inertia	
Max Radial Loading [N]	206			255			206			255	
Max Axial Loading [N]	69			98			69			98	
Vibration Grade [μm]	V15										
Vibration Capacity	19.6 m/s ² or lower (2.5G)										
Speed/Position Detector	Serial multi-turn built-in type (19-bit)										
Weight [kg]	0.56	0.74	1.06	2.68	3.3	1.28	1.46	1.78	3.45	4.07	

Note 1—The rated torque is the continuous permissible torque between the 0°C and 40°C operating temperature which is suitable for a servo motor mounted with the following heat sink dimensions: 250mm x 250mm x 6mm made from aluminum (or mounted to equipment with an equivalent heat sinking capability).



L7P/iX7NH AC Servo Systems

130mm Frame Motor Specifications

L7P/iX7NH 130mm Frame Motor Specifications														
Model	APM-FE15AMK-AD	APM-FE16DMK-AD	APM-FE22DMK-AD	APM-FE15AMK2-AD	APM-FE16DMK2-AD	APM-FE22DMK2-AD	APM-FEP09AMK-AD	APM-FEP15AMK-AD	APM-FEP16DMK-AD	APM-FEP22DMK-AD	APM-FEP09AMK2-AD	APM-FEP15AMK2-AD	APM-FEP16DMK2-AD	APM-FEP22DMK2-AD
Price	\$644.00	\$690.00	\$635.00	\$845.00	\$893.00	\$814.00	\$590.00	\$646.00	\$698.00	\$642.00	\$793.00	\$878.00	\$930.00	\$820.00
Drawing	PDF	PDF	PDF	PDF	PDF	PDF	PDF	PDF	PDF	PDF	PDF	PDF	PDF	PDF
Input Voltage	230VAC						460VAC							
Drive Compatibility	L7P and iX7NH drives						L7P drives							
Integrated Brake	No			Yes			No				Yes			
Flange Size (mm)	130													
Rated Power [kW]	1.5	1.6	2.2	1.5	1.6	2.2	0.9	1.5	1.6	2.2	0.9	1.5	1.6	2.2
Rated Torque [N·m] Note 1	4.77	7.63	10.5	4.77	7.63	10.5	2.86	4.77	7.64	10.5	2.86	4.77	7.64	10.5
Max. Torque [N·m]	14.32	22.92	31.51	14.32	22.92	31.51	8.59	14.32	22.92	31.51	8.59	14.32	22.92	31.51
Rated Speed [rpm]	3000	2000		3000	2000		3000		2000		3000		2000	
Max. Speed [rpm]	5000	3000		5000	3000		5000		3000		5000		3000	
Mechanical Time Constant [ms]	1.520	1.278	1.176	1.520	1.278	1.176	2.428	1.609	1.337	1.261	2.428	1.609	1.337	1.261
Rated current [Amps] rms	9.15	10.98	12.97	9.15	10.98	12.97	3.47	6.68	4.97	6.8	3.47	6.68	4.97	6.8
Max. Instantaneous Current [Amps] rms	27.45	32.94	38.91	27.45	32.94	38.91	10.4	20.03	14.92	20.4	10.4	20.03	14.92	20.4
Rated Power Rate [kW/s]	22.38	39.89	57.9	22.38	39.89	57.9	14.5	22.4	39.92	57.95	14.5	22.4	39.92	57.95
Electrical Time Constant [ms]	9.819	10.352	11.284	9.819	10.352	11.284	7.763	9.761	10.656	10.623	7.763	9.761	10.656	10.623
Insulation Class	B													
Insulation Resistance	10MΩ													
Insulation Strength	1.8 kVAC, 1 second						2.2 kVAC, 1 second							
Rotor Inertia [x10 ⁻⁴ kg m ²]	10.18	14.62	19.43	10.18	14.62	19.43	5.659	10.179	14.619	19.04	5.659	10.179	14.619	19.04
Allowable Load Inertia Ratio	10 times motor inertia													
Max Radial Loading [N]	725													
Max Axial Loading [N]	362													
Vibration Grade [μm]	15													
Vibration Capacity	5G													
Speed/Position Detector	Serial type (19-bit)													
Weight [kg]	6.7	8.5	10.1	8.28	10.02	11.59	5.04	6.7	8.5	10.1	6.58	8.28	10.02	11.59

Note 1—The rated torque is the continuous permissible torque between the 0°C and 40°C operating temperature which is suitable for a servo motor mounted with the following heat sink dimensions: 250mm x 250mm x 6mm made from aluminum (or mounted to equipment with an equivalent heat sinking capability).



L7P/iX7NH AC Servo Systems

180mm Frame Motor Specifications

L7P/iX7NH 180mm Frame Motor Specifications												
Model	APM-FF35DMK-AD	APM-FF55DMK-AD	APM-FF75DMK-AD	APM-FF35DMK2-AD	APM-FF55DMK2-AD	APM-FF75DMK2-AD	APM-FFP35DMK-AD	APM-FFP55DMK-AD	APM-FFP75DMK-AD	APM-FFP35DMK2-AD	APM-FFP55DMK2-AD	APM-FFP75DMK2-AD
Price	\$834.00	\$922.00	\$1,092.00	\$1,081.00	\$1,162.00	\$1,324.00	\$834.00	\$918.00	\$1,095.00	\$1,094.00	\$1,158.00	\$1,327.00
Drawing	PDF	PDF	PDF	PDF	PDF	PDF	PDF	PDF	PDF	PDF	PDF	PDF
Input Voltage	230VAC						460VAC					
Drive Compatibility	L7P and iX7NH drives						L7P drives					
Integrated Brake	No			Yes			No			Yes		
Flange Size (mm)	180											
Rated Power [kW]	3.5	5.5	7.5	3.5	5.5	7.5	3.5	5.5	7.5	3.5	5.5	7.5
Rated Torque [N·m] ^{Note 1}	16.7	26.25	35.81	16.7	26.25	35.81	16.71	26.26	35.81	16.71	26.26	35.81
Max. Torque [N·m]	50.1	78.76	89.53	50.1	78.76	89.53	50.13	65.65	89.52	50.13	65.65	89.52
Rated Speed [rpm]	2000											
Max. Speed [rpm]	3000											
Mechanical Time Constant [ms]	1.222	0.829	0.723	1.222	0.829	0.723	1.058	0.847	0.764	1.058	0.847	0.764
Rated current [Amps] rms	16.48	28.78	32.95	16.48	28.78	32.95	9.09	14.70	18.97	9.09	14.70	18.97
Max. Instantaneous Current [Amps] rms	49.44	86.34	82.38	49.44	86.34	82.38	27.26	36.75	47.42	27.26	36.75	47.42
Rated Power Rate [kW/s]	59.89	93.27	120.15	59.89	93.27	120.15	59.98	93.38	120.15	59.98	93.38	120.15
Electrical Time Constant [ms]	15.021	19.086	20.567	15.021	19.086	20.567	14.452	23.484	20.351	14.452	23.484	20.351
Insulation Class	B											
Insulation Resistance	10MΩ											
Insulation Strength	1.8 kVAC, 1 second						2.2 kVAC, 1 second					
Rotor Inertia [x10 ⁻⁴ kg m ²]	46.56	73.85	106.7	46.56	73.85	106.7	46.56	73.85	106.73	46.56	73.85	106.73
Allowable Load Inertia Ratio	5 times motor inertia											
Max Radial Loading [N]	1548											
Max Axial Loading [N]	519											
Vibration Grade [μm]	15											
Vibration Capacity	5G											
Speed/Position Detector	Serial type (19-bit)											
Weight [kg]	17.4	25.2	34	24.6	32.4	39	17.4	25.2	34	24.6	32.4	39

Note 1—The rated torque is the continuous permissible torque between the 0°C and 40°C operating temperature which is suitable for a servo motor mounted with the following heat sink dimensions: 250mm x 250mm x 6mm made from aluminum (or mounted to equipment with an equivalent heat sinking capability).



L7P/iX7NH AC Servo Systems

Environmental Specifications

L7P/iX7NH Motor Environmental Specifications			
Model Series	APMC-FBL/FCL Motors	FE/FEP Motors	FF/FFP Motors
IP Rating	Fully closed self-cooling IP67 ¹	Fully closed self-cooling IP65 ¹	
Rated Time	Continuous		
Operating Temperature	0 to 40 °C [32 to 104 °F]		
Storage Temperature	-10 to 60 °C [14 to 140 °F]		
Operating Humidity	Below 80% RH		
Storage Humidity	Below 90% RH (non condensing)		
Atmosphere	Avoid direct sunlight and corrosive/flammable gas or liquid		
E/V	Elevation/vibration 49m/s ² (5G)		
Agency Approvals	cUR _{US} (E255738), CE		

Note 1 - Shaft connection not included. The IP rating for attached reducers/gearboxes is not guaranteed. Cables may not qualify marked IP rating if bent beyond designated specifications. Use suggested cables for maintaining IP rating.

Accessories

CN1 Accessories

For iX7NH series drives, two methods are available for creating I/O connections.

Option 1:

Terminal blocks + cables:

- [APCS-L7NCN1T-AD](#)
- [APCS-L7NCN1T01-AD](#)
- [APCS-L7NCN1T015-AD](#)
- [APCS-L7NCN1T02-AD](#)

APCS-L7NCN1T terminals ship with a universal labeling strip (A1-A10, B1-B10). A labeling template with designations specifically for the iX drive can be downloaded from any of the drive pages or the terminal block page (www.automationdirect.com/pn/apcs-l7ncn1t-ad).

Option 2:

Flying lead cables:

- [APCS-CN101A-AD](#)
- [APCS-CN102A-AD](#)
- [APCS-CN103A-AD](#)



APCS-L7NCN1T-AD



APCS-CN101A-AD

Part Number	Price	Description	Cable Length	Drawing	Compatible Drives
APCS-L7NCN1T-AD	\$56.00	LS Electric CN1 feedthrough terminal block, 20-pole, DIN rail mount. For use with all LS Electric iX7 series drives.	0.5 m [1.6 ft]	PDF	All iX7NH drives
APCS-L7NCN1T01-AD	\$59.00		1.0 m [3.2 ft]	PDF	
APCS-L7NCN1T015-AD	\$61.00		1.5 m [4.9 ft]	PDF	
APCS-L7NCN1T02-AD	\$63.00		2.0 m [6.5 ft]	PDF	
APCS-CN101A-AD	\$39.00	LS Electric CN1 control cable, 20-pin connector to pigtail.	1.0 m [3.2 ft]	PDF	
APCS-CN102A-AD	\$43.00		2.0 m [6.5 ft]	PDF	
APCS-CN103A-AD	\$45.00		3.0 m [9.8 ft]	PDF	



iX7NH Series Accessories

Accessories

iX7NH Terminal Assignment Table



CAUTION: This terminal assignment table is for use with iX7NH drives ONLY. Using this table with non-iX7NH series drives could damage your equipment as terminal assignments are different for each drive series.

APCS-L7NCN1Txxx-AD

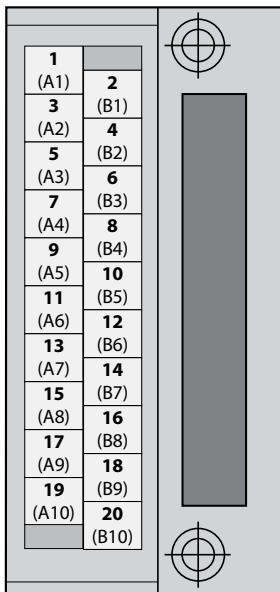

You can download a printable terminal label at
<https://www.automationdirect.com/pn/APCS-L7NCN1T-AD>

iX7NH Drive Terminal Assignments					
Terminal	Drive I/O Pin/Wire #	Description	Wire Color	Stripe Color	Number of Stripes
A1	1	DO1	Yellow	Black	1
B1	2	DOCOM	Yellow	Red	1
A2	3	DO2	Yellow	Black	2
B2	4	DO3	Yellow	Red	2
A3	5	AGND	Yellow	Black	3
B3	6	+24V	Yellow	Red	3
A4	7	DI3	Yellow	Black	4
B4	8	DI4	Yellow	Red	4
A5	9	AO	Yellow	Black	5
B5	10	/AO	Yellow	Red	5
A6	11	DI1	White	Black	1
B6	12	DI2	White	Red	1
A7	13	DI5	White	Black	2
B7	14	DI6	White	Red	2
A8	15	A-TLMT	White	Black	3
B8	16	GND	White	Red	3
A9	17	ZO	White	Black	4
B9	18	/ZO	White	Red	4
A10	19	BO	White	Black	5
B10	20	/BO	White	Red	5

Accessories, continued

NOTE: These parts available for sale to North American locations only

iX7NH System STO Cables

Use these pre-made factory cables to easily connect the drive STO connector to a safety relay.

Part Number	Price	Length	Description	Drawing	Compatible Motors
APCS-STO03A-AD	\$40.00	0.3 m [1ft]	LS Electric STO cable, 6-pin connector to pigtail,	PDF	All iX7NH series drives
APCS-STO10A-AD	\$42.00	1m [3.2 ft]		PDF	
APCS-STO30A-AD	\$45.00	3m [9.8 ft]		PDF	



APCS-STO series cable

iX7NH STO Bypass Connector

Replacement STO bypass connector. Note that each drive ships with an APCS-CN6K bypass connector included - this is only needed as a replacement.

Part Number	Price	Description	Compatible Motors
APCS-CN6K-AD	\$19.00	LS Electric STO connector, replacement, 6-pin. For use with all LS Electric iX7 series drives.	All iX7NH series drives



APCS-CN6K-AD

Accessories, continued

NOTE: These parts available for sale to North American locations only

L7C/L7P/iX7NH System Motor Encoder Cables

Part Number	Price	Flex Rated	Length	Gauge	Drawing	Compatible Motors
APCS-EN03ES-AD	\$48.00	N	3m [9.8 ft]	24AWG	PDF	APMC motors with 17-bit incremental encoders (AYK/AYK2 motors)
APCS-EN05ES-AD	\$58.00		5m [16.4 ft]		PDF	
APCS-EN10ES-AD	\$67.00		10m [32.8 ft]		PDF	
APCS-EN20ES-AD	\$79.00		20m [65.6 ft]		PDF	
APCS-EF03ES-AD	\$70.00	Y	3m [9.8 ft]		PDF	
APCS-EF05ES-AD	\$83.00		5m [16.4 ft]		PDF	
APCS-EF10ES-AD	\$116.00		10m [32.8 ft]		PDF	
APCS-EF20ES-AD	\$188.00		20m [65.6 ft]		PDF	
APCS-EN03ES1-AD	\$79.00	N	3m [9.8 ft]	24AWG	PDF	FBL/FCL series motors with 19-bit encoders
APCS-EN05ES1-AD	\$83.00		5m [16.4 ft]		PDF	
APCS-EN10ES1-AD	\$96.00		10m [32.8 ft]		PDF	
APCS-EN20ES1-AD	\$120.00		20m [65.6 ft]		PDF	
APCS-EF03ES1-AD	\$99.00	Y	3m [9.8 ft]		PDF	
APCS-EF05ES1-AD	\$117.00		5m [16.4 ft]		PDF	
APCS-EF10ES1-AD	\$159.00		10m [32.8 ft]		PDF	
APCS-EF20ES1-AD	\$244.00		20m [65.6 ft]		PDF	
APCS-EN03DS1-AD	\$83.00	N	3m [9.8 ft]	24AWG	PDF	APM-FE/APM-FF series motors
APCS-EN05DS1-AD	\$88.00		5m [16.4 ft]		PDF	
APCS-EN10DS1-AD	\$99.00		10m [32.8 ft]		PDF	
APCS-EN20DS1-AD	\$123.00		20m [65.6 ft]		PDF	
APCS-EF03DS1-AD	\$104.00	Y	3m [9.8 ft]		PDF	
APCS-EF05DS1-AD	\$120.00		5m [16.4 ft]		PDF	
APCS-EF10DS1-AD	\$159.00		10m [32.8 ft]		PDF	
APCS-EF20DS1-AD	\$246.00		20m [65.6 ft]		PDF	



APCS-EN series encoder cable



APCS-ENxxxES1 series encoder cable



APC-EF00BS-AD

L7P/iX7NH System Encoder Accessories

Part Number	Price	Description	Compatible Drives
APC-EF00BS-AD	\$20.00	17-pin motor encoder connector.	APM-FE and APM-FF series motors
APCS-BATT36-AD	\$36.00	Encoder battery. One (1) AA ER6V lithium battery with extended leads and an encoder cable connector.	All LS Electric motors with 19-bit encoders



APCS-BATT36-AD



LS Electric AC Servo Systems

Accessories, *continued*

NOTE: These parts available for sale to North American locations only

L7C/L7P/iX7NH System Motor Brake Power Cables

Part Number	Price	Flex Rated	Length	Gauge	Drawing	Compatible Motors
<u>APCS-BN03QS-AD</u>	\$52.00	N	3m [9.8 ft]	18AWG	<u>PDF</u>	APMC FBL/FCL brake motors (100W – 1kW)
<u>APCS-BN05QS-AD</u>	\$55.00		5m [16.4 ft]		<u>PDF</u>	
<u>APCS-BN10QS-AD</u>	\$61.00		10m [32.8 ft]		<u>PDF</u>	
<u>APCS-BN20QS-AD</u>	\$74.00		20m [65.6 ft]		<u>PDF</u>	
<u>APCS-BF03QS-AD</u>	\$58.00	Y	3m [9.8 ft]		<u>PDF</u>	
<u>APCS-BF05QS-AD</u>	\$63.00		5m [16.4 ft]		<u>PDF</u>	
<u>APCS-BF10QS-AD</u>	\$79.00		10m [32.8 ft]		<u>PDF</u>	
<u>APCS-BF20QS-AD</u>	\$108.00		20m [65.6 ft]		<u>PDF</u>	



APCS-BN series brake cable

iX7NH System Non-Brake Motor Power Cables

Part Number	Price	Flex Rated	Length	Gauge	Drawing	Compatible Motors
APCS-PN03LSX-AD	\$48.00	N	3m [9.8 ft]		PDF	FBL/FCL series motors
APCS-PN05LSX-AD	\$53.00		5m [16.4 ft]		PDF	
APCS-PN10LSX-AD	\$65.00		10m [32.8 ft]		PDF	
APCS-PN20LSX-AD	\$94.00		20m [65.6 ft]		PDF	
APCS-PF03LSX-AD	\$55.00	Y	3m [9.8 ft]	PDF		
APCS-PF05LSX-AD	\$65.00		5m [16.4 ft]	PDF		
APCS-PF10LSX-AD	\$93.00		10m [32.8 ft]	PDF		
APCS-PF20LSX-AD	\$146.00		20m [65.6 ft]	PDF		
APCS-PN03HSX1-AD	\$48.00	N	3m [9.8 ft]		PDF	APM-FE15A series motors without brake
APCS-PN05HSX1-AD	\$55.00		5m [16.4 ft]		PDF	
APCS-PN10HSX1-AD	\$72.00		10m [32.8 ft]		PDF	
APCS-PN20HSX1-AD	\$108.00		20m [65.6 ft]		PDF	
APCS-PF03HSX1-AD	\$56.00	Y	3m [9.8 ft]	PDF		
APCS-PF05HSX1-AD	\$68.00		5m [16.4 ft]	PDF		
APCS-PF10HSX1-AD	\$100.00		10m [32.8 ft]	PDF		
APCS-PF20HSX1-AD	\$158.00		20m [65.6 ft]	PDF		
APCS-PN03HSX-AD	\$44.00	N	3m [9.8 ft]		PDF	APM-FE16D and APM-FE22D series motors without brake
APCS-PN05HSX-AD	\$53.00		5m [16.4 ft]		PDF	
APCS-PN10HSX-AD	\$74.00		10m [32.8 ft]		PDF	
APCS-PN20HSX-AD	\$116.00		20m [65.6 ft]		PDF	
APCS-PF03HSX-AD	\$57.00	Y	3m [9.8 ft]	PDF		
APCS-PF05HSX-AD	\$74.00		5m [16.4 ft]	PDF		
APCS-PF10HSX-AD	\$116.00		10m [32.8 ft]	PDF		
APCS-PF20HSX-AD	\$200.00		20m [65.6 ft]	PDF		
APCS-PN03ISX-AD	\$49.00	N	3m [9.8 ft]		PDF	APM-FF35D motors without brake
APCS-PN05ISX-AD	\$57.00		5m [16.4 ft]		PDF	
APCS-PN10ISX-AD	\$79.00		10m [32.8 ft]		PDF	
APCS-PN20ISX-AD	\$120.00		20m [65.6 ft]		PDF	
APCS-PF03ISX-AD	\$63.00	Y	3m [9.8 ft]	PDF		
APCS-PF05ISX-AD	\$80.00		5m [16.4 ft]	PDF		
APCS-PF10ISX-AD	\$124.00		10m [32.8 ft]	PDF		
APCS-PF20ISX-AD	\$213.00		20m [65.6 ft]	PDF		

NOTE: These parts available for sale to North American locations only



APCS-PxxLSX series power cable



APCS-PxxHSX1 series power cable



APCS-PxxHSX series power cable



iX7NH Series Accessories

Accessories, continued

iX7NH System Brake Motor Power Cables

Part Number	Price	Flex Rated	Length	Gauge	Drawing	Compatible Motors
Note: For FBL/FCL 100W–1kW motors with brake, use the power cables on the previous page AND separate brake cable APCS-BxxxQS-AD from page tMNC-282. This is for FBL/FCL motors only. FE and FF motors have brake wiring incorporated into the power cable (below).						
APCS-PN03NBX1-AD	\$58.00	N	3m [9.8 ft]		PDF	APM-FE15A series motors with brakes
APCS-PN05NBX1-AD	\$68.00		5m [16.4 ft]		PDF	
APCS-PN10NBX1-AD	\$94.00		10m [32.8 ft]		PDF	
APCS-PN20NBX1-AD	\$144.00		20m [65.6 ft]		PDF	
APCS-PF03NBX1-AD	\$72.00	Y	3m [9.8 ft]		PDF	
APCS-PF05NBX1-AD	\$91.00		5m [16.4 ft]		PDF	
APCS-PF10NBX1-AD	\$139.00		10m [32.8 ft]		PDF	
APCS-PF20NBX1-AD	\$237.00		20m [65.6 ft]		PDF	
APCS-PN03NBX-AD	\$51.00	N	3m [9.8 ft]		PDF	APM-FE16D and APM-FE22D series motors with brakes
APCS-PN05NBX-AD	\$61.00		5m [16.4 ft]		PDF	
APCS-PN10NBX-AD	\$86.00		10m [32.8 ft]		PDF	
APCS-PN20NBX-AD	\$137.00		20m [65.6 ft]		PDF	
APCS-PF03NBX-AD	\$67.00	Y	3m [9.8 ft]		PDF	
APCS-PF05NBX-AD	\$89.00		5m [16.4 ft]		PDF	
APCS-PF10NBX-AD	\$137.00		10m [32.8 ft]		PDF	
APCS-PF20NBX-AD	\$243.00		20m [65.6 ft]		PDF	
APCS-PN03PBX-AD	\$70.00	Y	3m [9.8 ft]		PDF	APM-FF35D series motors with brakes
APCS-PN05PBX-AD	\$82.00		5m [16.4 ft]		PDF	
APCS-PN10PBX-AD	\$117.00		10m [32.8 ft]		PDF	
APCS-PN20PBX-AD	\$184.00		20m [65.6 ft]		PDF	
APCS-PF03PBX-AD	\$89.00	N	3m [9.8 ft]		PDF	
APCS-PF05PBX-AD	\$117.00		5m [16.4 ft]		PDF	
APCS-PF10PBX-AD	\$182.00		10m [32.8 ft]		PDF	
APCS-PF20PBX-AD	\$315.00		20m [65.6 ft]		PDF	



APCS-PxxNBX1 series power cable



APCS-PxxNBX series power cable



APCS-PxxPBX series power cable

Accessories, continued





LS Drive System Replacement Connectors

Part Number	Price	Description	Compatible Drives	Image
<u>5452573</u>	\$6.50	AutomationDirect replacement drive power connector.	All L7C drives	
<u>APC-CN1NNA-AD</u>	\$17.50	LS solder-type CN1 50-pin Electric I/O connector.	All L7C and L7P series drives	
<u>APC-CN2NNA-AD</u>	\$15.00	LS Electric I/O connector, replacement, 20-pin.	All iX7NH series drives	
<u>APC-CN3NNA-AD</u>	\$17.50	LS Electric solder-type CN2 14-pin drive encoder connector.	All L7C, L7P, and iX7NH series drives	
<u>APCS-CN6K-AD</u>	\$19.00	LS Electric STO connector, replacement, 6-pin. For use with all LS Electric iX7 series drives.	All iX7NH series drives	
<u>IX7-CON-A</u>	\$19.00	AutomationDirect drive power connector, replacement, 11-pin. Note: Do not wire to pin 4 (the "N" terminal).	iX7NH series drives, 400W, 750W, and 1kW	
<u>IX7-CON-B</u>	\$19.00	AutomationDirect drive power connector for motor power, replacement, 4-pin.	iX7NH series drives, 400W, 750W, and 1kW	
<u>IX7-CON-C</u>	\$9.00	AutomationDirect drive power connector release, replacement.	iX7NH series drives, 400W, 750W, and 1kW	
<u>IX7-CON-D</u>	\$19.00	AutomationDirect drive power connector for motor power, replacement, 4-pin	iX7NH series drives, 2kW and 3.5 kW	
<u>IX7-CON-E</u>	\$19.00	AutomationDirect drive control power connector, replacement, 5-pin.	iX7NH series drives, 2kW and 3.5 kW	
<u>IX7-CON-F</u>	\$19.00	AutomationDirect drive main power connector, replacement, 6-pin.	iX7NH series drives, 2kW and 3.5 kW	
<u>L7P-CON-A</u>	\$15.00	Replacement 11-pin drive power connector. Do not wire to pin 4 (the "N" terminal)	L7PA series 230VAC 400W and 1kW drives	
<u>L7P-CON-B</u>	\$8.00	Replacement 3-pin drive power connector.	L7PA series 230VAC 400W and 1kW drives	

Continued on next page

Accessories, *continued*

LS Drive System Replacement Connectors, *continued*

Part Number	Price	Description	Compatible Drives	Image
<u>L7P-CON-C</u>	\$20.00	Replacement 11-pin drive power connector.	L7PB series 460VAC 1kW drives, all L7P series 2kW and 3.5 kW drives	
<u>L7P-CON-D</u>	\$7.50	Replacement 3-pin drive power connector.	L7PB series 460VAC 1kW drives, all L7P series 2kW and 3.5 kW drives	
<u>L7P-CON-E</u>	\$0.50	Drive analog monitor crimp pins (24-48 AWG), package of 5.	All L7P and iX7NH drives. Requires L7P-CON-F	
<u>L7P-CON-F</u>	\$2.00	Drive analog monitor 4-pin crimp connector.	All L7P and iX7NH drives. Requires L7P-CON-E	
<u>L7P-CON-G</u>	\$2.00	Drive analog monitor 4-pin IDC connector (26AWG).	All L7P and iX7NH series drives	

Accessories, continued

L7C/L7P/iX7NH System Braking Resistors

Use external braking resistors to provide additional regenerative capacity and to dissipate heat away from the servo drive.

Part Number	Price	Description	Drawing	Compatible Drive Series	Compatible Drive Models
<u>APCS-140R50-AD</u>	\$18.50	LS Electric 140W 30Ω encapsulated braking resistor	<u>PDF</u>	All 400W LS drives	L7CA004U-AD L7PA004U-AD IX7NHA004U-AD
<u>APCS-300R30-AD</u>	\$24.00	LS Electric 300W 30Ω encapsulated braking resistor	<u>PDF</u>	All 230VAC 750W and 1kW LS drives	L7CA010U-AD L7PA010U-AD IX7NHA008U-AD IX7NHA010U-AD
<u>APC-600R30-AD</u>	\$42.00	LS Electric 600W 30Ω encapsulated braking resistor.	<u>PDF</u>	All 230VAC 2.2 kW and 3.5 kW LS drives	L7PA020U-AD L7PA035U-AD IX7NHA020U-AD IX7NHA035U-AD
<u>APC-600R28-AD</u>	\$64.00	LS Electric 600W 28Ω encapsulated braking resistor.	<u>PDF</u>	All 230VAC 5.5 kW and 7.5 kW LS drives	L7PA050U-AD L7PA075U-AD
<u>APCS-300R82-AD</u>	\$16.00	LS Electric 300W 82Ω encapsulated braking resistor.	<u>PDF</u>	All 460VAC 1kW LS drives	L7PB010U-AD
<u>APCS-600R140-AD</u>	\$42.00	LS Electric 600W 140Ω encapsulated braking resistor.	<u>PDF</u>	Alternate resistor for 460VAC 2.2 kW and 3.5 kW LS drives	Alternate resistor for L7PB020U-AD L7PB035U-AD
<u>APCS-600R75-AD</u>	\$42.00	LS Electric 600W 75Ω encapsulated braking resistor.	<u>PDF</u>	All 460VAC 2.2, 3.5, 5.5, and 7.5 kW LS drives	L7PB020U-AD L7PB035U-AD L7PB050U-AD L7PB075U-AD



NOTE: 600W resistors require customer-supplied M5-.8 bolts and cable lugs for connection.



APCS-140R50-AD

LS ELECTRIC AC Servo Systems Accessories

Servo System EMI Filters

Input EMI filters reduce electromagnetic interference or noise on the input side of the servo drive. They are required for CE compliance and recommended for installations prone to or sensitive to electromagnetic interference.

Part Number	Price	Rating	Description	Drawing	Compatible Drive Series	Compatible Drive Models
<u>TB1-10A0D0</u>	\$67.00	10A	LS Electric EMI input filter, 250 VAC, 1-phase, 10A, panel mount, EMI/RFI filtering, 2-stage, drive rated, standard performance, screw terminals. For use with 1-phase AC drives.	<u>PDF</u>	All L7C series drives	L7CA004U-AD L7CA010U-AD
<u>TB6-B010LBEI</u>	\$86.00	10A	LS Electric EMI input filter, 550VAC, 3-phase, panel mount, EMI/RFI filtering, drive rated, standard performance, screw terminals.	<u>PDF</u>	L7P and iX7NH 400W through 1kW drives	L7PA004U-AD L7PA010U-AD L7PB010U-AD IX7NHA004U-AD IX7NHA008U-AD IX7NHA010U-AD
<u>TB6-B020NBDC</u>	\$110.00	20A		<u>PDF</u>	L7P 460V 2kW and 3.5 kW drives	L7PB020U-AD L7PB035U-AD
<u>TB6-B030NBDC</u>	\$104.00	30A		<u>PDF</u>	L7P and iX7NH 230V: 2kW, 3.5 kW and L7P 460V: 5kW	L7PA020U-AD L7PA035U-AD L7PB050U-AD IX7NHA020U-AD IX7NHA035U-AD
<u>TB6-B040AS</u>	\$180.00	40A		<u>PDF</u>	L7P 230V: 5kW 460V: 7.5 kW	L7PA050U-AD L7PB075U-AD
<u>TB6-B060LAS</u>	\$313.00	50A		<u>PDF</u>	L7P 230V: 7.5 kW drives	L7PA075U-AD



TB1-10A0D0



TB6-B010LBEI

Accessories, continued

NOTE: These parts available for sale to North American locations only

L7C/L7P/iX7NH/PHOX System Planetary Gearboxes

Precision planetary gearboxes can increase the torque output of servo systems while reducing the reflected load inertia for higher response. Gearboxes offer high stiffness, high efficiency, and very quiet operation. Input motor shaft clamp, oversized output shaft key, and mounting hardware are included for mating to LS Electric motors.

Features:

- Maintenance free (no need to replace lubrication)
- IP65
- Operating temperature range of -10°C to +90°C [14°F to 194°F]
- Uses VIGO Grease RE #0



MSS Series Planetary Gearbox

MSS Series Planetary Gearbox Specifications										
Model	96200004	96200005	96200103	96200007	96200008	96200257	96200373	96200378	96200393	96200459
Manufacturer Part Number	MSS0601A-005KS-B3110103C14	MSS0601A-010KS-B3110103C14	MSS0902B-020KS-B3110103C14	MSS0901A-005KS-C3110103C19	MSS0901A-010KS-C3110103C19	MSS1152B-020KS-C4120103C19	MSS0901A-005KS-C4120103C19	MSS0901A-010KS-C4120103C19	MSS1152B-020KS-C4120103C19	MSS1151A-005KS-D3110103C22
Compatible Motors	APMC-FBL series 100, 200, 300, and 400 W motors			APMC FCL series 750W and 1kW motors			APM-FE series 900W and 1.5 kW motors			APM-FE series 1.6 kW motors
Price	\$288.00	\$296.00	\$528.00	\$387.00	\$387.00	\$762.00	\$350.00	\$350.00	\$699.00	\$499.00
Drawing	PDF	PDF	PDF	PDF	PDF	PDF	PDF	PDF	PDF	PDF
Ratio	5:1	10:1	20:1	5:1	10:1	20:1	5:1	10:1	20:1	5:1
Nominal Output Torque	54 N·m	42 N·m	143 N·m	160 N·m	121 N·m	295 N·m	160 N·m	121 N·m	295 N·m	332 N·m
Inertia	0.13 kg/cm ²	0.13 kg/cm ²	0.13 kg/cm ²	0.48 kg/cm ²	0.44 kg/cm ²	0.48 kg/cm ²	0.48 kg/cm ²	0.44 kg/cm ²	0.48 kg/cm ²	2.81 kg/cm ²
Output Shaft Diameter	16mm	16mm	22mm	22mm	22mm	32mm	22mm	22mm	32mm	32mm
Stage	1	1	2	1	1	2	1	1	2	1
Frame	60mm	60mm	90mm	90mm	90mm	115mm	90mm	90mm	115mm	115mm
Nominal Input Speed (rpm)	5,000	5,000	4,000	4,000	4,000	4,000	4,000	4,000	4,000	4,000
Max Input Speed (rpm)	10,000	10,000	8,000	8,000	8,000	8,000	8,000	8,000	8,000	8,000
Emergency Stop Torque	3 times nominal output torque									
Noise (dB)	≤54	≤54	≤56	≤56	≤56	≤59	≤56	≤56	≤59	≤59
Efficiency (%)	≥97	≥97	≥94	≥97	≥97	≥94	≥97	≥97	≥94	≥97
Backlash (Arcmin)	≤7	≤7	≤9	≤7	≤7	≤9	≤7	≤7	≤9	≤7
Max Radial Load (N)	1,280	1,280	3,200	3,200	3,200	6,800	3,200	3,200	6,800	6,800
Max Axial Load (N)	690	690	1,600	1,600	1,600	3,400	1,600	1,600	3,400	3,400
Service Life (Hours)	20,000 (10,000 under continuous operation)									
Continued on next page										



LS Electric AC Servo Systems

Accessories, continued

MSS Series Planetary Gearbox Specifications											
Model	96200464	96200479	96200010	96200011	96200445	96200013	96200014	96200701	96200016	96200017	96200862
Manufacturer Part Number	MSS1151A-010KS-D3110103C22	MSS1422B-020KS-D3110103C22	MSS1151A-005KS-D3110103C24	MSS1151A-010KS-D3110103C24	MSS1422B-020KS-D3110103C24	MSS1421A-005KS-E3110103C35	MSS1421A-010KS-E3110103C35	MSS1802B-020KS-E3110103C35	MSS1801A-005KS-F3110103C42	MSS1801A-010KS-F3110103C42	MSS1802A-015KS-F3110103C42
Compatible Motors	APM-FE series 1.6 kW motors		APM-FE series 2.2 kW motors			APM-FF series 3.5 kW and 5.5 kW motors			APM-FF series 7.5 kW motors		
Price	\$499.00	\$1,030.00	\$499.00	\$499.00	\$1,030.00	\$770.00	\$770.00	\$1,850.00	\$1,480.00	\$1,480.00	\$1,850.00
Drawing	PDF	PDF	PDF	PDF	PDF	PDF	PDF	PDF	PDF	PDF	PDF
Ratio	10:1	20:1	5:1	10:1	20:1	5:1	10:1	20:1	5:1	10:1	15:1
Nominal Output Torque	262 N·m	295 N·m	332 N·m	262 N·m	295 N·m	634 N·m	500 N·m	1060 N·m	1195 N·m	960 N·m	897 N·m
Inertia	2.59 kg/cm ²	2.81 kg/cm ²	2.81 kg/cm ²	2.59 kg/cm ²	2.81 kg/cm ²	7.52 kg/cm ²	7.05 kg/cm ²	7.52 kg/cm ²	24.29 kg/cm ²	23.51 kg/cm ²	24.29 kg/cm ²
Output Shaft Diameter	32mm	40mm	32mm	32mm	40mm	40mm	40mm	55mm	55mm	55mm	55mm
Stage	1	2	1	1	2	1	1	2	1	1	2
Frame	115mm	142mm	115mm	115mm	142mm	142mm	142mm	180mm	180mm	180mm	180mm
Nominal Input Speed (rpm)	4,000	3,000	4,000	4,000	3,000	3,000	3,000	3,000	3,000	3,000	3,000
Max Input Speed (rpm)	8,000	6,000	8,000	8,000	6,000	6,000	6,000	6,000	6,000	6,000	6,000
Emergency Stop Torque	3 times nominal output torque										
Noise (dB)	≤59	≤62	≤59	≤59	≤62	≤62	≤62	≤64	≤64	≤64	≤64
Efficiency (%)	≥97	≥94	≥97	≥97	≥94	≥97	≥97	≥94	≥97	≥97	≥94
Backlash (Arcmin)	≤7	≤9	≤7	≤7	≤9	≤7	≤7	≤9	≤7	≤7	≤9
Max Radial Load (N)	6,800	9,300	6,800	6,800	9,300	9,300	9,300	15,100	15,100	15,100	15,100
Max Axial Load (N)	3,400	4,500	3,400	3,400	4,500	4,500	4,500	7,500	7,500	7,500	7,500
Service Life (Hours)	20,000 (10,000 under continuous operation)										