



50W to 100W Hazardous Location Heaters



020100-00 and 020100-01



020110-00 and 020110-01

Applications

STEGO convection heaters are used in areas with explosion hazard to maintain minimum operating temperatures to help prevent failure of electronic components caused by condensation and corrosion.

Features

- Large convection surface
- Maintenance free
- DIN rail mountable



50W to 100W Hazardous Location Heaters Specifications	
Heating Element	High performance cartridge
Heater Body	Aluminum profile, silver anodized
Connection	Si HF – JZ 3 x 18 AWG [0.75 mm ²], length 3.3 ft [1m]
Connection PE	4mm ²
Mounting	Clip for 35mm DIN rail, EN 60715
Mounting Position	Vertical only
Storage Temperature	-49 to 158°F [-45 to 70°C]
Recommended Mounting Distance	1.97 in [50mm] all sides
Protection Class / Type	I (grounded) / IP6X
Explosion Protection (EN)	LCIE (Laboratoire Central des Industries Electriques)
Conformity Certificate	LCIE 01 ATEX 6073X / 06, IECEx LCI 07.0020 X
Approvals	CE, EAC submitted

To obtain the most current agency approval information, see the Agency Approval Checklist section on the specific part number's web page at www.AutomationDirect.com

50W to 100W Hazardous Location Heaters									
Part Number	Price	Heating Capacity	Operating Voltage	Pre-fuse T (Time Delay)	Ambient Temp ¹	Ex Protection Type		Surface Temperature	Weight (approx.)
						Gases	Dusts		
020100-01	\$157.00	50W	110-120V AC	1.0 A	-40 to 122°F [-40 to 50°C]	Ex d IIC T5 Gb	Ex tb IIIC T100°C Db IP6X	T5 = 212°F [100°C]	2.9 lb [1.3 kg]
					-40 to 185°F [-40 to 85°C]	Ex d IIC T4 Gb	Ex tb IIIC T135°C Db IP6X	T4 = 275°F [135°C]	
020100-00	\$157.00	50W	230-240V AC	0.5 A	-40 to 122°F [-40 to 50°C]	Ex d IIC T5 Gb	Ex tb IIIC T100°C Db IP6X	T5 = 212°F [100°C]	2.9 lb [1.3 kg]
					-40 to 185°F [-40 to 85°C]	Ex d IIC T4 Gb	Ex tb IIIC T135°C Db IP6X	T4 = 275°F [135°C]	
020110-01	\$192.00	100W	110-120V AC	2.0 A	-40 to 122°F [-40 to 50°C]	Ex d IIC T4 Gb	Ex tb IIIC T135°C Db IP6X	T5 = 275°F [135°C]	3.3 lb [1.5 kg]
					-40 to 185°F [-40 to 85°C]	Ex d IIC T3 Gb	Ex tb IIIC T200°C Db IP6X	T4 = 392°F [200°C]	
020110-00	\$192.00	100W	230-240V AC	1.0 A	-40 to 122°F [-40 to 50°C]	Ex d IIC T4 Gb	Ex tb IIIC T135°C Db IP6X	T5 = 275°F [135°C]	3.3 lb [1.5 kg]
					-40 to 185°F [-40 to 85°C]	Ex d IIC T3 Gb	Ex tb IIIC T200°C Db IP6X	T4 = 392°F [200°C]	

¹ Ambient temperature outside of the cabinet/enclosure



50W to 100W Hazardous Location Heaters

Dimensions: Inches [mm]

020100-00 and 020100-01

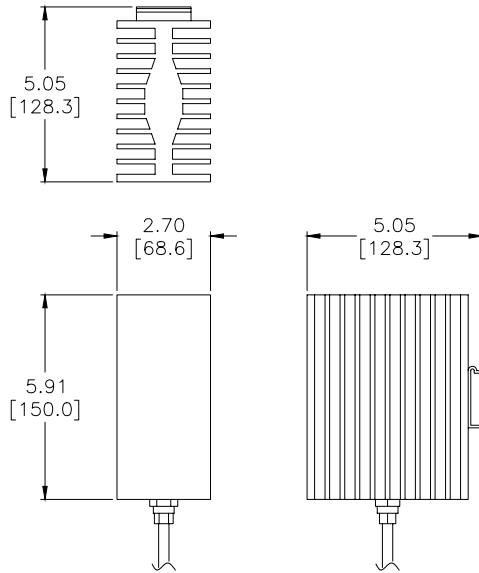

020110-00 and 020110-01

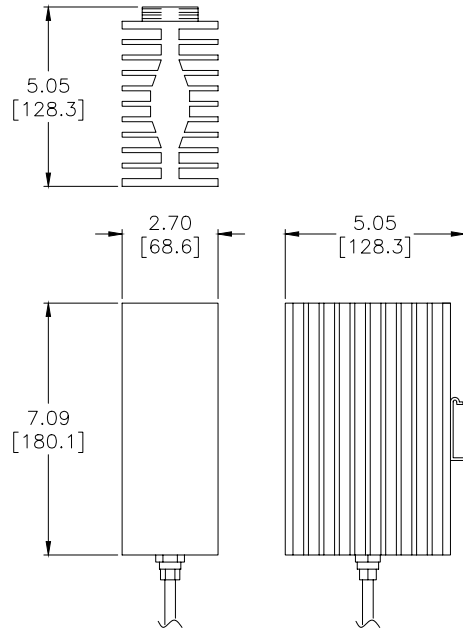

Please see our website www.AutomationDirect.com for complete engineering drawings.



50W to 200W Hazardous Location Heaters



020310-00

Applications

Compact convection heater of temperature class T3 (392°F/200°C max.) for use in hazardous areas to prevent formation of condensation, temperature fluctuations, and for protection against frost in control and switch cabinets, as well as in measuring equipment.

Features

- For use in hazardous areas
- Large convection surface
- DIN rail and screw mounting
- Ready to use with strain relief
- Maintenance free
- Temperature class T3



50W to 200W Hazardous Location Heaters Specifications	
Temperature Class	T3
Ex Protection Type	11 2 GD
Gases	Ex db IIC T3 Gb
Dusts	Ex tb IIIC T200 °C Db IP66
Ambient Temperature	-76 to 185°F [-60 to 85°C]
Surface Temperature	Max. 392°F [200°C]
Heating Element	High performance cartridge
Heating Body	Aluminum profile, silver anodized
Connection	Silicone cable (halogen-free) 3 x 18 AWG [0.82 mm ²], length 3ft [1m]
Connection PE	18 to 14 AWG [0.75 to 2.55 mm ²]
Housing	aluminum, silver anodized
Mounting	Clip for 35mm DIN rail, EN 60715 for heating body sizes 3.2 x 1.9" and 4.7 x 2.4"
Mounting Position	Vertical airflow (connection at bottom)
Storage Temperature	-76 to +185°F [-60 to 85°C]
Operating / Storage Humidity	Max. 90% RH (non-condensing)
Protection Type / Protection Class	IP66 / I (grounded)
Approvals	EPS 16 ATEX 1109X IECEx EPS 16.0048X EAC, CE 0081 Ex 11 2 GD

50W to 200W Hazardous Location Heaters						
Part Number	Price	Operating Voltage	Heating Capacity	Rec. Pre-fuse T (time-delay)	Dimensions	Weight (lb)
020310-00	\$137.00	AC 230V	50W	0.5A	4.33 x 1.89 x 3.15 [110 x 48 x 80]	1.5
020319-00	\$137.00	AC 120V	50W	1.0A	4.33 x 1.89 x 3.15 [110 x 48 x 80]	1.5
020320-00	\$157.00	AC 230V	100W	1.0A	7.09 x 1.89 x 3.15 [180 x 48 x 80]	2.2
020329-00	\$157.00	AC 120V	100W	2.0A	7.09 x 1.89 x 3.15 [180 x 48 x 80]	2.2
020340-00	\$174.00	AC 230V	200W	2.0A	9.45 x 2.36 x 4.72 [240 x 60 x 120]	3.7
020349-00	\$174.00	AC 120V	200W	4.0A	9.45 x 2.36 x 4.72 [240 x 60 x 120]	3.7

Dimensions in inches [millimeters]



50W to 200W Hazardous Location Heaters

Dimensions:

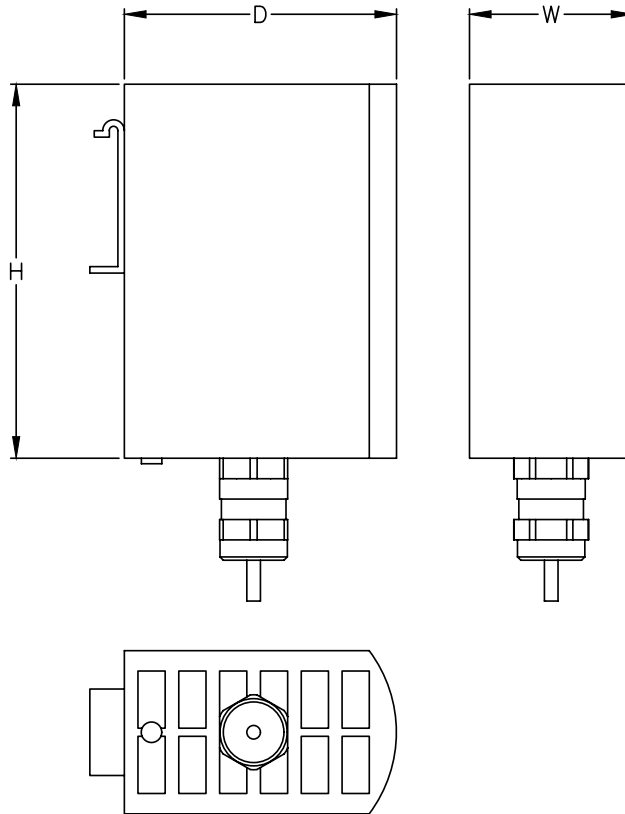

Please see our website www.AutomationDirect.com for complete engineering drawings.

Enclosure Heating and Heater Selection

Why Heat an Enclosure?

Today's miniaturization of enclosure components results in high packing densities, which in turn results in higher temperatures within the enclosure. These high temperatures are harmful to electronic components. In response, cooling systems have become standard in many applications. However, just as critical and widely underestimated, are failures caused by the formation of moisture.

Under certain climatic conditions, moisture can build up not only in outdoor or poorly insulated enclosures, but also in highly protected and well-sealed enclosures.

Moisture and Failure

Moisture, especially when combined with aggressive gases and dust, causes atmospheric corrosion and can result in the failure of components such as circuit breakers, busbars, relays, integrated circuit boards and transformers. The greatest danger lies in conditions where electronic equipment is exposed to relatively high air humidity or extreme variations in temperature, such as day-and-night operation or outdoor installation. Failure of components in such cases is usually caused by changing contact resistances, flashovers, creepage currents or reduced insulation properties.

Eliminate Moisture

Moisture and corrosion will remain low if relative air humidity stays below 60%. However, relative humidity above 65% will significantly increase moisture and corrosion problems. This can be prevented by keeping the environment inside an enclosure at a temperature as little as 9°F (5°C) higher than that of the ambient air. Constant temperatures are a necessity to guarantee optimal operating conditions. Continuous temperature changes not only create condensation but they reduce the life expectancy of electronic components significantly. Electronic components can be protected by cooling during the day and heating at night.

Thermal Management

Modern enclosure heaters are designed to protect against condensation. They heat the air inside enclosures, preventing water vapor from condensing on components while providing the greatest possible air circulation and low energy consumption.

Other heating element technology improvements include:

- Longer operating life
- Greater energy efficiencies
- Quick wiring options
- Easier mounting
- Fan heaters should be considered for larger enclosures to ensure that the entire enclosure is heated uniformly

Heater Location

Ideally, most heaters will perform optimally when mounted near the bottom of an enclosure and used in conjunction with a control device, thermostat, and/or hygrostat. The control device may be a separate device, or it may be integral to the heater. With the controller located in an area of the cabinet that is representative of the average temperature or humidity

requirement, the heater should then be placed in a position near the bottom of the enclosure. If a separate control device is used, the heater should not be located directly beneath the controller to ensure that the controller is not influenced by direct heat from the heater.

Heater Calculation

Follow Steps 1-5 to determine the heating requirement of an enclosure (US units - left column, metric - right)

STEP 1: Determine the Surface Area (A) of your enclosure which is exposed to open air.

Enclosure Dimensions:

height = _____ feet _____ meters

width = _____ feet _____ meters

depth = _____ feet _____ meters

Choose Mounting Option from next page, and calculate the surface area as indicated

$$A = \text{_____ ft}^2 \text{ or } \text{_____ m}^2$$

STEP 2: Choose the Heat Transmission Coefficient (k) for your enclosure's material of construction.

painted steel = 0.511 W/(ft²•K) 5.5 W/(m²•K)

stainless steel = 0.344 W/(ft²•K) 3.7 W/(m²•K)

aluminum = 1.115 W/(ft²•K) 12 W/(m²•K)

plastic or insulated

stainless = 0.325 W/(ft²•K) 3.5 W/(m²•K)

$$k = \text{_____ W/(ft}^2\text{•K)} \text{ or } \text{_____ W/(m}^2\text{•K)}$$

STEP 3: Determine the Temperature Differential (ΔT).

A. Desired enclosure interior temp. = _____ °F _____ °C

B. Lowest ambient (outside) temp. = _____ °F _____ °C

Subtract B from A = Temp. diff. (ΔT) = _____ °F _____ °C

For these calculations, ΔT must be in degrees Kelvin (K). Therefore, divide ΔT (°F) by 1.8. ΔT = _____ K

STEP 4: Determine Heating Power (P_V), if any (generated from existing components, i.e. transformer).

$$P_V = \text{_____ W} \text{ or } \text{_____ W}$$

STEP 5: Calculate the Required Heating Power (P_H) for your enclosure based on the above values.

If enclosure is located inside:

$$P_H = (A \times k \times \Delta T) - P_V = \text{_____ W}$$

If enclosure is located outside:

$$P_H = 2 \times (A \times k \times \Delta T) - P_V = \text{_____ W}$$

Enclosure Mounting Types and Surface Area Calculations

1. Free-Standing

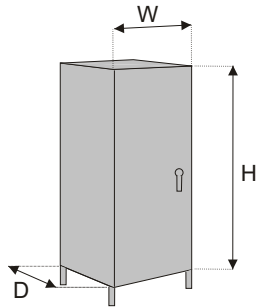

$$\text{Area (A)} = 1.8 (H \times W) + 1.8 (H \times D) + 1.8 (W \times D)$$

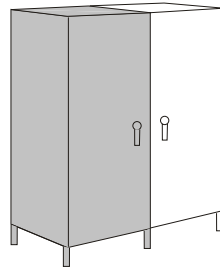

$$\text{Area (A)} = 1.8 (H \times W) + 1.4 (H \times D) + 1.8 (W \times D)$$

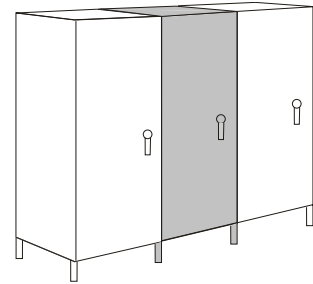

$$\text{Area (A)} = 1.8 (H \times W) + (H \times D) + 1.8 (W \times D)$$

2. Wall-Mounted

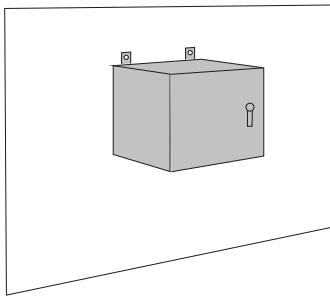

$$\text{Area (A)} = 1.4 (H \times W) + 1.8 (H \times D) + 1.8 (W \times D)$$

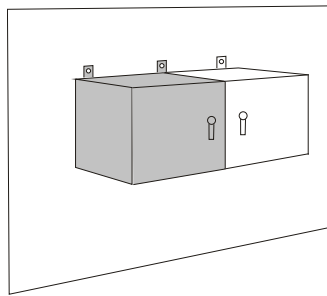

$$\text{Area (A)} = 1.4 (H \times W) + 1.4 (H \times D) + 1.8 (W \times D)$$

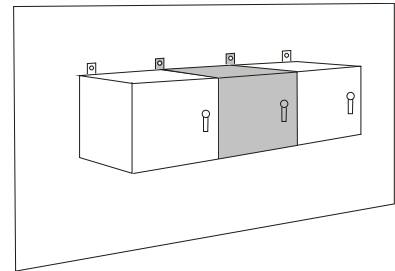

$$\text{Area (A)} = 1.4 (H \times W) + (H \times D) + 1.8 (W \times D)$$

3. Ground

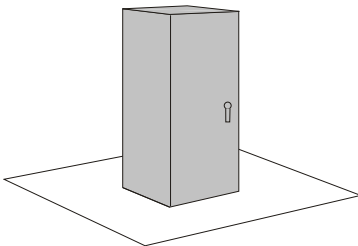

$$\text{Area (A)} = 1.8 (H \times W) + 1.8 (H \times D) + 1.4 (W \times D)$$

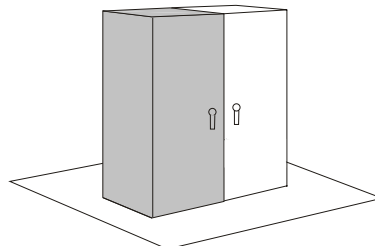

$$\text{Area (A)} = 1.8 (H \times W) + 1.4 (H \times D) + 1.4 (W \times D)$$

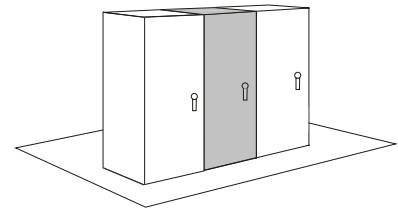

$$\text{Area (A)} = 1.8 (H \times W) + (H \times D) + 1.4 (W \times D)$$

4. Ground and Wall

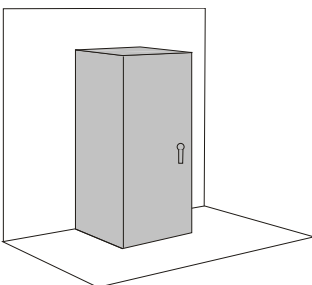

$$\text{Area (A)} = 1.4 (H \times W) + 1.8 (H \times D) + 1.4 (W \times D)$$

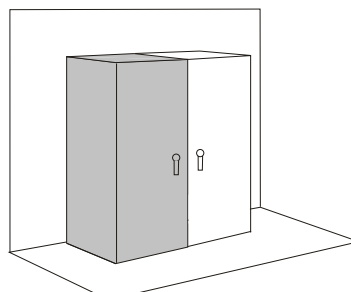

$$\text{Area (A)} = 1.4 (H \times W) + 1.4 (H \times D) + 1.4 (W \times D)$$

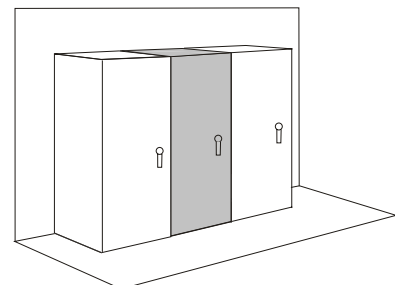

$$\text{Area (A)} = 1.4 (H \times W) + (H \times D) + 1.4 (W \times D)$$