

# GS/DURAPULSE Drives Accessories – Dynamic Braking Component Selection – GS3

## Braking Component Selection for GS3 DURApulse AC Drives

GS3 AC Drive Braking Component Selection												
Drive Voltage	Motor Power		125% Braking Torque @ 10% Duty cycle**						Max Braking Torque			
	(hp)	(kW)	AC Drive Model #	Braking Unit		Braking Resistor		Brake Torque (kg-m)	Total Brake Current (A)	Min Resistor Value (Ω)	Max Total Brake Current (A)	Peak Power (W)
				Quantity	Part # GS-	Quantity	Part # GS-					
			GS3-									
230V	1	0.7	21P0	0	n/a	1	21P0-BR	0.5	1.9	82	4.6	1.8
	2	1.5	22P0			1	22P0-BR	1.0	3.8	82	4.6	1.8
	3	2.2	23P0			1	23P0-BR	1.5	5.4	82	4.6	1.8
	5	3.7	25P0			1	25P0-BR***	2.5	9.5	33	11.5	4.4
	7.5	5.5	27P5			1	27P5-BR	3.7	12.7	30	12.7	4.8
	10	7.5	2010			1	2010-BR-ENC	5.1	19.0	20	19.0	7.2
	15	11	2015			1	2015-BR-ENC	7.5	27.9	13.6	27.9	10.6
	20	15	2020	1	2DBU	1	2020-BR-ENC	10.2	38.0*	10*	38.0*	14.4*
	25	18	2025	1	2DBU	1	2025-BR-ENC	12.2	47.5*	8*	47.5*	18.1*
	30	22	2030	1	2DBU	1	2030-BR-ENC	14.9	55.9*	6.8*	55.9*	21.2*
	40	30	2040	2	2DBU	2	2040-BR-ENC	20.3	38.0*	10*	38.0*	14.5*
50	37	2050	2	2DBU	2	2050-BR-ENC	25.1	47.5*	8*	47.5*	18.1*	
460V	1	0.7	41P0	0	n/a	1	41P0-BR	0.5	1.0	160	4.8	3.6
	2	1.5	42P0			1	42P0-BR	1.0	1.9	160	4.8	3.6
	3	2.2	43P0			1	43P0-BR	1.5	3.0	160	4.8	3.6
	5	3.7	45P0			1	45P0-BR	2.5	5.1	130	5.8	4.4
	7.5	5.5	47P5			1	47P5-BR	3.7	7.6	91	8.4	6.3
	10	7.5	4010			1	4010-BR	5.1	10.1	62	12.3	9.3
	15	11	4015			1	4015-BR-ENC	7.5	15.2	39	19.5	14.8
	20	15	4020	1	4DBU	1	4020-BR-ENC	10.2	19.0*	40*	19.0*	14.4*
	25	18	4025	1	4DBU	1	4025-BR-ENC	12.2	23.8*	32*	23.8*	18.1*
	30	22	4030	1	4DBU	1	4030-BR-ENC	14.9	27.9*	27.2*	27.9*	21.2*
	40	30	4040	1	4DBU	1	4040-BR-ENC	20.3	38.0*	20*	38.0*	28.9*
	50	40	4050	1	4DBU	1	4050-BR-ENC	25.1	47.5*	16*	47.5*	36.1*
	60	45	4060	1	4DBU	1	4060-BR-ENC	30.5	55.9*	13.6*	55.9*	42.5*
	75	55	4075	2	4DBU	2	4075-BR-ENC	37.2	38.0*	20*	38.0*	28.9*
100	75	4100	2	4DBU	2	4100-BR-ENC	50.8	55.9*	13.6*	55.9*	42.5*	

\* These values are per individual DBU, as seen between DBU terminals B1 and B2.  
 \*\* 10% Duty Cycle with maximum ON (braking) time of 10 seconds.  
 \*\*\* GS-25P0-BR can be also be used with SureServo AC Servo Drive # SVA-2040.

NOTE: For DURApulse GS3 series AC drives 20 hp and above, dynamic braking units must be used in conjunction with braking resistors.

# GS4 DURAPULSE Drives Accessories – Dynamic Braking Component Selection – GS4

## Braking Component Selection for GS4 DURApulse AC Drives

GS4 AC Drive Braking Component Selection														
Drive Voltage	Motor Power		125% Braking Torque @ 10% Duty Cycle**						Max Braking Torque					
			AC Drive Model # GS4-	Braking Unit		Braking Resistor		Brake Torque (kg-m)	Total Brake Current (A)	Min Resistor Value (Ω)	Max Total Brake Current (A)	Peak Power (kW)		
	Quantity	Part # GS-		Quantity	Part # GS-BR-									
230V	1	0.7	21P0	0	n/a	1	080W200	0.5	1.9	63.3	6	2.3		
	2	1.5	22P0			1	200W091	1.0	4.2	47.5	8	3.0		
	3	2.2	23P0			1	300W070	1.5	5.4	38.0	10	3.8		
	5	3.7	25P0			1	400W040	2.5	9.5	19.0	20	7.6		
	7.5	5.5	27P5			1	1K0W020	3.7	19	14.6	26	9.9		
	10	7.5	2010			1	1K0W020	5.1	19	14.6	26	9.9		
	15	11	2015			1	1K5W013	7.5	29	12.6	28	10.6		
	20	15	2020			2	1K0W4P3	10.2	44	8.3	46	17.5		
	25	18	2025			2	1K0W4P3	12.2	44	8.3	46	17.5		
	30	22	2030			2	1K5W3P3	14.9	58	5.8	66	25.1		
	40	30	2040			2	1DBU	4	1K0W5P1	20.3	75*	4.8*	80*	30.4*
	50	37	2050			2	2DBU	4	1K2W3P9	25.1	97*	3.2*	120*	45.6*
	60	45	2060			2	2DBU	4	1K5W3P3	30.5	118*	3.2*	120*	45.6*
	75	55	2075	3	2DBU	6	1K2W3P9	37.2	145*	2.1*	180*	68.4*		
100	75	2100	4	2DBU	8	1K2W3P9	50.8	190*	1.6*	240*	91.2*			
460V	1	0.7	41P0	0	n/a	1	080W750	0.5	1	190	4	3.0		
	2	1.5	42P0			1	200W360	1	2.1	126.7	6	4.6		
	3	2.2	43P0			1	300W250	1.5	3	108.6	7	5.3		
	5	3.7	45P0			1	400W150	2.5	5.1	84.4	9	6.8		
	7.5	5.5	47P5			1	1K0W075	3.7	10.2	54.3	14	10.6		
	10	7.5	4010			1	1K0W075	5.1	10.2	47.5	16	12.2		
	15	11	4015			1	1K5W043	7.5	17.6	42.2	18	13.7		
	20	15	4020			2	1K0W016	10.2	24	26.2	29	22.0		
	25	18	4025			2	1K0W016	12.2	24	23.0	33	25.1		
	30	22	4030			2	1K5W013	14.9	29	23.0	33	25.1		
	40	30	4040			4	1K0W016	20.3	47.5	14.1	54	41.0		
	50	40	4050			1	4DBU	4	1K2W015	25.1	50*	12.7*	60*	45.6*
	60	45	4060			1	4DBU	4	1K5W013	30.5	59*	12.7*	60*	45.6*
	75	55	4075	2	3DBU	8	1K0W5P1	37.2	76*	9.5*	80*	60.8*		
	100	75	4100	2	4DBU	8	1K2W015	50.8	100*	6.3*	120*	91.2*		
	125	90	4125	2	4DBU	8	1K5W013	60.9	117*	6.3*	120*	91.2*		
	150	110	4150	1	5DBU	10	1K2W015	74.5	126*	6.0*	126*	95.8*		
	175	132	4175	1	6DBU	12	1K5W012	89.4	190*	4.0*	190*	144.4*		
	200	160	4200	1	6DBU	12	1K5W012	108.3	190*	4.0*	190*	144.4*		
	250	185	4250	1	7DBU	14	1K5W012	125.3	225*	3.4*	225*	172.1*		
300	220	4300	2	5DBU	20	1K2W015	148.9	252*	3.0*	252*	190.5*			

\* These values are per individual DBU, as seen between DBU terminals B1 and B2.  
\*\* 10% Duty Cycle with maximum ON (braking) time of 10 seconds.

# GS/DURAPULSE Drives Accessories – Braking Unit Specifications for GS3 & GS4 DURAPULSE AC Drives

## Braking Units for GS3 & GS4 DURApulse AC Drives

### Overview

Braking units are applied to absorb the motor regeneration energy when the three-phase induction motor stops by deceleration.

GS-xDBU braking units, used with GS series braking resistors, provide optimum braking performance.



**NOTE: BRAKING UNITS ARE AVAILABLE ONLY FOR DURAPULSE DRIVES.**



**WARNING: To avoid injury or mechanical damage, please refer to user manual GS-DB\_UMP before wiring.**



Dynamic Braking Unit Specifications – for GS3 & GS4 DURAPULSE AC Drives								
Braking Unit Part Number	GS-1DBU	GS-2DBU	GS-3DBU	GS-4DBU	GS-5DBU	GS-6DBU	GS-7DBU	
Price	\$217.00	\$223.00	\$294.00	\$347.00	\$1,224.00	\$1,276.00	\$1,393.00	
Nominal Voltage (VAC)	230			460				
Max Motor Capacity (hp/[kW])	20 [15]	30 [22]	40 [30]	60 [45]	150 [110]	200 [160]	250 [185]	
Output Rating	Max Discharge Current (A) @ 10% Duty Cycle*	40	60	40	60	126	225	
	Continuous Discharge Current (A)	15	20	15	18	45	100	
	Braking Startup Voltage (VDC)	330/345/360/ 380/400/415 ±3V		600/690/720/ 760/800/830 ±6V		618/642/667/690/ 725/750 ±6V		
	Maximum On-Time (s)	10						
Input DC Voltage (VDC)	200–400		400–800		400–750			
Min Equivalent Resistor for Each Braking Unit (Ω)	10	6.8	20	13.6	6	4	3.4	
Protection	Power CHARGE Lamp/LED	Comes ON until DC bus voltage (+P – -N) drops below 50VDC			Comes ON when DC bus voltage (DC+ – DC-) rises above 300VDC. Goes OFF when DC bus voltage (DC+ – DC-) drops below 100VDC.			
	Braking ACT Lamp/LED	ON during braking						
	Fault ERR Lamp	ON if a fault has occurred				n/a		
	Overcurrent Level LED (A)	n/a				190	290	340
	Overheat LED	n/a				Comes ON > 176°F [80°C]; Goes OFF < 149°F [65°C]		
	Heat Sink Overheat Temperature	203°F [95°C]				n/a		
	Alarm Output Relay Contact	5A @ 120VAC/28VDC (RA,RB,RC)				3A @ 250VAC/28VDC (RA,RC)		
Environment	Installation Location	indoor (no corrosive gases; no metallic dust)						
	Operating Temperature	14°F to 122 °F [-10 to +50 °C]						
	Storage Temperature	-4 to +140 °F [-20 to +60 °C]						
	Humidity	less than 90% RH, non-condensing						
	Vibration	9.8 m/s <sup>2</sup> [1G] under 20Hz ; 2m/s <sup>2</sup> [0.2G] at 20–50 Hz						
Mechanical Configuration	IP50 wall-mount enclosed				IP10 wall-mount enclosed			

\* 10% Duty Cycle with maximum ON (braking) time of 10 seconds

# GS/DURAPULSE Drives Accessories – Braking Unit Basic Wiring for GS3 & GS4 DURAPULSE AC Drives

## Basic Dynamic Braking Wiring Diagram for GS3 & GS4 DURAPULSE AC Drives



**NOTE:** GS2 SERIES AC DRIVES CAN CONNECT DIRECTLY TO BRAKING RESISTORS, AND DO NOT REQUIRE DYNAMIC BRAKING UNITS FOR BRAKING.



**NOTE:** SMALLER-CAPACITY DURAPULSE AC DRIVES CAN CONNECT DIRECTLY TO BRAKING RESISTORS, AND DO NOT REQUIRE DYNAMIC BRAKING UNITS FOR BRAKING. OTHER APPLICATIONS REQUIRE MULTIPLE RESISTORS AND/OR MULTIPLE DYNAMIC BRAKING UNITS. REFER TO “DYNAMIC BRAKING COMPONENT SELECTION” TO DETERMINE WHICH BRAKING COMPONENTS ARE REQUIRED FOR YOUR APPLICATION(S), AND TO THE DURAPULSE DRIVES DYNAMIC BRAKING USER MANUAL FOR COMPLETE WIRING DIAGRAMS.

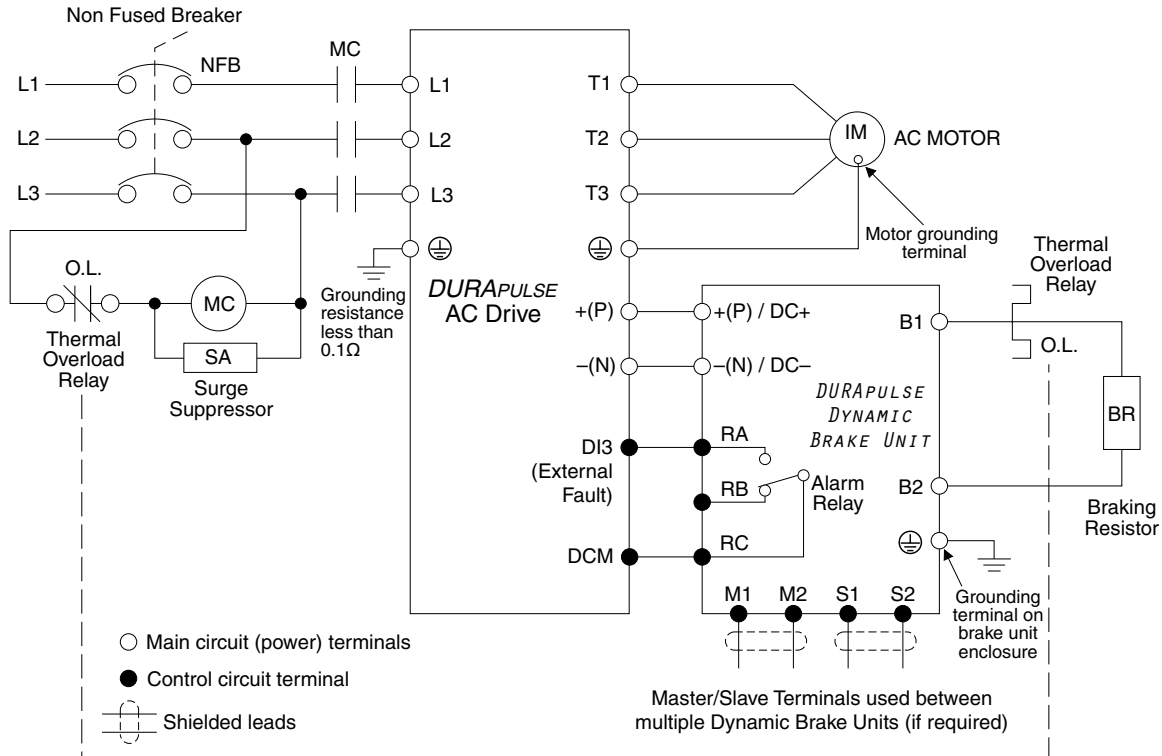

# GS/DURAPULSE Drives Accessories – Braking Unit Dimensions for GS3 & GS4 DURAPULSE AC Drives

## Braking Unit Dimensions ( Dimensions = mm [in] )

See our website: [www.AutomationDirect.com](http://www.AutomationDirect.com) for complete engineering drawings.

### A) DBU ≤ 100hp (GS-1DBU, GS-2DBU, GS-3DBU, GS-4DBU)

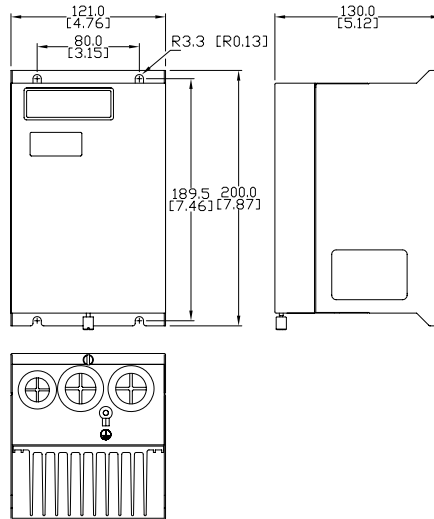

### B) DBU > 100hp (GS-5DBU, GS-6DBU, GS-7DBU)

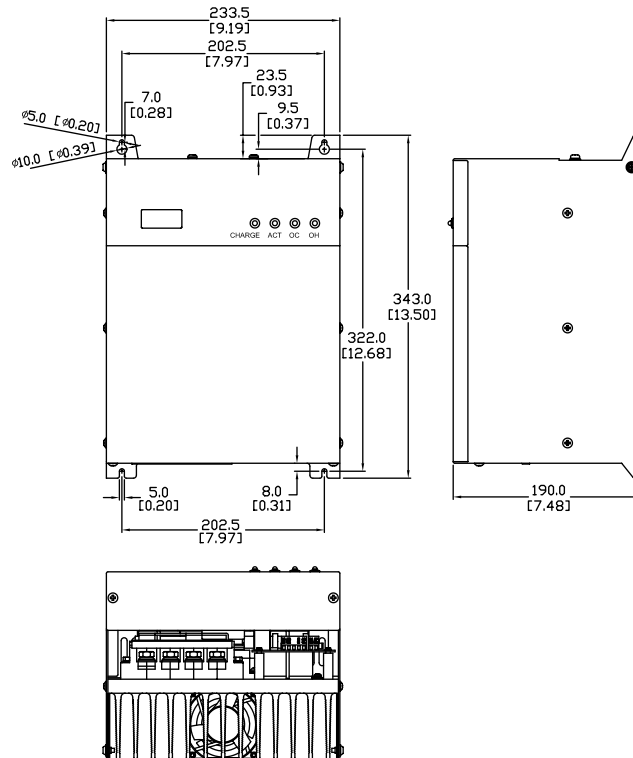

# AC Drives Optional Accessories – Overview

*Drive Accessories*  
(not all accessories are applicable for every drive model)

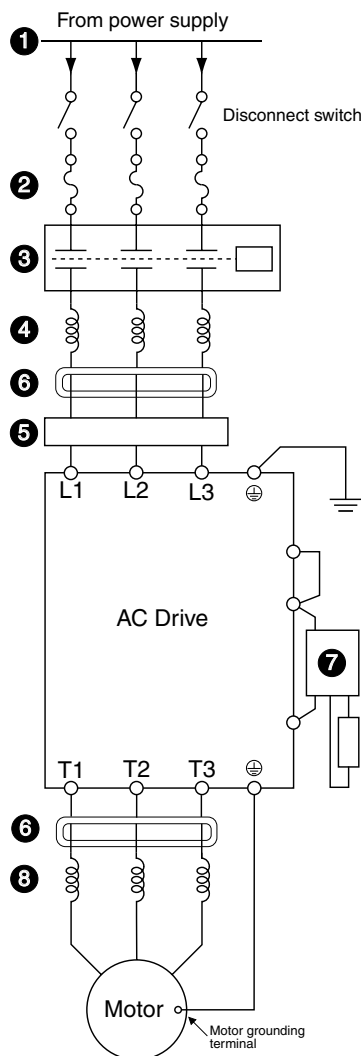

## 1 Power Supply

Please follow the specific power supply requirements as detailed in the specific drive manual.

## 2 Fuses

Input fuses protect the AC drive from excessive input current due to line surges, short circuits, and ground faults. They are recommended for all installations and may be required for UL-listed installations.

## 3 Contactor (Optional)

Do not use a contactor or disconnect switch for run/stop control of the AC drive and motor. This will reduce the operating life cycle of the AC drive. Cycling a power circuit switching device while the AC drive is in run mode should be done only in emergency situations.

## 4 Input Line Reactor (Optional)

See the Line Reactors section at [www.automationdirect.com](http://www.automationdirect.com) for more information.

Input line reactors protect the AC drive from transient overvoltage conditions, typically caused by utility capacitor switching. The input line reactor also reduces the harmonics associated with AC drives. Input line reactors are recommended for all installations.

## 5 EMI filter (Optional)

See the EMI Filters section at [www.automationdirect.com](http://www.automationdirect.com) for more information.

Input EMI filters reduce electromagnetic interference or noise on the input side of the AC drive. They are required for CE compliance and recommended for installations prone to or sensitive to electromagnetic interference.

## 6 RF filter (Optional)

RF filters reduce the radio frequency interference or noise on the input or output side of the inverter.

## 7 Braking Unit and/or Braking Resistor (Optional)

Dynamic braking allows the AC drive to produce additional braking (stopping) torque. AC drives can typically produce between 15% & 20% braking torque without the addition of any external components. The addition of optional braking may be required for applications that require rapid deceleration or high inertia loads.

## 8 Output Load Reactor or Voltage Time (dV/dT) Filter (Optional)

Output line reactors protect the motor insulation against AC drive short circuits and IGBT reflective wave damage, and also “smooth” the motor current waveform, allowing the motor to run cooler. They are **recommended for operating “non-inverter-duty” motors and when the length of wiring between the AC drive and motor is less than 100 feet.**

**Voltage Time filters provide enhanced protection for motors with distances up to 1,000 feet.**

Voltage Time filters provide even more protection against wave reflection and reduce common mode noise. They are recommended when the length of wiring between the AC drive and motor is from 100 feet up to 1,000 feet.

See [www.automationdirect.com](http://www.automationdirect.com) for specific product offerings.