

Light Duty Incremental Encoders (SAE Dimension Encoders)

TRDA-2E series

Accessories

Accessories for TRDA-2E Series Encoders		
Part Number	Price	Description
<u>F-2D</u>	\$45.50	JTEKT round mounting flange, 1.86in bolt hole circle, (1.05in height), metal. For use with JTEKT TRDA-2E series encoders. Flange and encoder mounting hardware included.
<u>F-3D</u>	\$83.00	JTEKT round mounting flange, 2.95in bolt hole circle (1.34in height), metal. For use with JTEKT TRDA-2E series encoders. Flange and encoder mounting hardware included.
<u>F-6D</u>	\$63.00	JTEKT round mounting flange, 1.86in bolt hole circle, (1.34in height), metal. For use with JTEKT TRDA-2E series encoders. Flange and encoder mounting hardware included.
<u>F-7D</u>	\$45.50	JTEKT round mounting flange, 1in bolt hole circle (0.20in height), metal. For use with JTEKT TRDA-2E series encoders. Flange and encoder mounting hardware included.
<u>F-8D</u>	\$64.00	JTEKT round mounting flange, 2.95in bolt hole circle, (1.71in height), metal. For use with JTEKT TRDA-2E series encoders. Flange and encoder mounting hardware included.
<u>2ET-035D</u>	\$68.00	JTEKT right angle bracket, metal. For use with JTEKT TRDA-2E series encoders. Bracket and encoder mounting hardware included.

Couplings

For encoders with a solid shaft, please select a coupling that fits your encoder. All couplings are in stock, ready to ship.

See the "Encoder Couplings" section for more information.



2ET-035D



F-2D



F-3D



F-6D



F-7D



F-8D

Light Duty Incremental Encoders (SAE Dimension Encoders)

Dimensions – TRDA-2E series

Dimensions = in [mm]

F-2D Mounting Flange

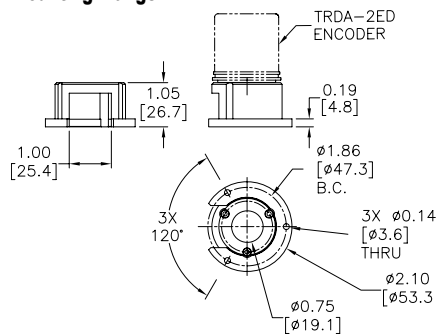

F-7D Mounting Flange

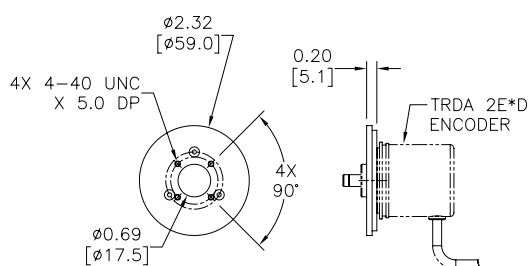

F-3D Mounting Flange

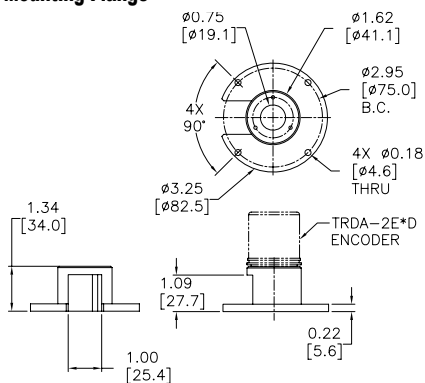

F-8D Mounting Flange

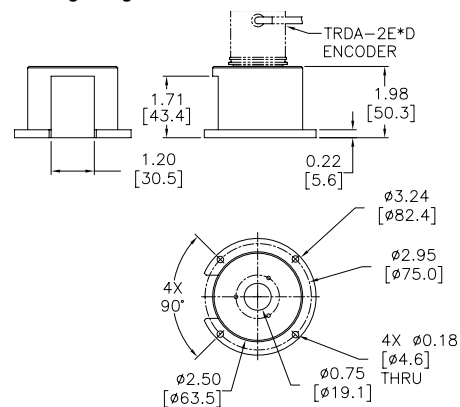

F-6D Mounting Flange

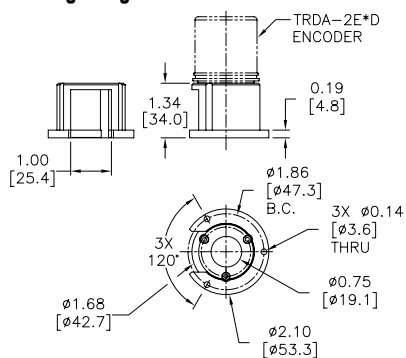

Light Duty Incremental Encoders (Metric Dimension Encoders)

TRD-MX series Features

A light duty incremental rotary encoder that is cost-effective for small applications; has the following features:

- Small body with 25mm diameter and 29mm depth
- 4 mm diameter solid shaft
- Resolution available from 100 pulses per revolution to 1024 pulses per revolution
- Open collector output (4.5–13.2 or 10.8–26.4 VDC), or line driver output (4.75–5.25 VDC)
- Up to 100 kHz response frequency
- Two-meter cable with tinned ends
- IP50 environmental rating
- Mounting bracket and couplings are available



TRD-MXxxx-AD/BD models



TRD-MXxxx-VD models

Light Duty Solid-shaft Incremental Encoders (NPN Open-collector Output, TRD-MXxxxAD/ BD)					
Part Number	Price	Pulses per Revolution	Input Voltage	Output	Body Dia.
TRD-MX100AD	Retired	100	4.5–13.2 VDC	NPN Open Collector	25 mm
TRD-MX360AD	Retired	360			
TRD-MX500BD	Retired	500	10.8–26.4 VDC		

Light Duty Solid-shaft Incremental Encoders (Line Driver Output, TRD-MXxxxVD)					
Part Number	Price	Pulses per Revolution	Input Voltage	Output	Body Dia.
TRD-MX100VD	Retired	100	4.75–5.25 VDC	Line Driver	25mm
TRD-MX360VD	Retired	360			
TRD-MX500VD	Retired	500			

Accessories

Accessories for TRD-MX Series Encoders		
Part Number	Price	Description
MM-4D	Retired	Servo mounting clamp for TRD-MX series encoders
MT-030D	\$43.00	Right-angle mounting bracket for TRD-MX series encoders



MM-4D



MT-030D

Couplings

For encoders with a solid shaft, please select a coupling that fits your encoder. All couplings are typically in stock, and ready to ship.

See the “Encoder Couplings” section for more information.



Couplings

Light Duty Incremental Encoders (Metric Dimension Encoders)

Specifications – TRD-MX series

Electrical Specifications (Metric Dimension Light Duty TRD-MX)					
Model		TRD-MXxxxAD (open collector)	TRD-MXxxxBD (open collector)	TRD-MXxxxVD (line driver)	
Power Supply	Operating Voltage *	5–12 VDC (nominal) * 4.5–13.2 VDC	12–24 VDC (nominal) * 10.8–26.4 VDC	5VDC (nominal) * 4.75–5.25 VDC	
	Allowable Ripple	3% rms max			
	Current Consumption	50 mA max (no load)			
	Circuit Protection Required	Limit current to 100 mA or less		–	
Output Waveform	Signal Waveform	Quadrature + home position			
	Max. Response Frequency	100 kHz			
	Operating Speed	(max response frequency / resolution) x 60 Hz			
	Duty Ratio (Symmetry)	50% ±25%			
	Index Signal Width (at Home Position)	100% ±50%			
Output	Rise/Fall Time **	2µs ** (sink current < 30 mA)		0.1 µs max ** (source current < 20 mA)	
	Output Type	Open collector (NPN sinking)		Line driver (26C31 or equivalent)	
	Output Logic	Negative logic (active low)		Positive logic (active high)	
	Output Current	Inflow	30 mA max		20 mA max
		Outflow	–		
	Output Voltage	H	–		2.5V min (source current < 20 mA)
		L	0.4V max (sink current < 30 mA)		0.5V max (source current < 20 mA)
	Load Power Voltage	30 VDC max		–	
Short-circuit Protection	–		–		
* To be supplied by Class II source. ** Cable length ≤2m or less. Maximum load.					
Mechanical Specifications (Metric Dimension Light Duty TRD-MX)					
Starting Torque	0.001 N m [0.009 lb in] max @ 20 °C [68 °F]				
Max. Allowable Shaft Load	Axial: 5N [1.1 lb]; Radial: 10N [2.2 lb]				
Max. Allowable Speed	6000 rpm (highest speed that can support the mechanical integrity of encoder)				
Wire Size	26 AWG, shielded, oil-resistant PVC				
Weight	approx 120g [0.3 lb]				
Environmental Specifications (Metric Dimension Light Duty TRD-MX)					
Ambient Temperature	-10 to +70 °C [14 to +158 °F]				
Storage Temperature	-25 to +85 °C [-13 to +185 °F]				
Operating Humidity	35–85% RH (non-condensing)				
Withstand Voltage *	630V grounded through capacitor (a 630V cap is connected between 0V & FG lines)				
Insulation Resistance	20 MΩ min				
Vibration Resistance	durable for one hour along three axes @ 10 to 55 Hz with 0.75mm half-amplitude				
Shock Resistance	490 m/s ² (11 ms applied 3-times, each X, Y, Z)				
Mounting Orientation	can be mounted in any orientation				
Protection	IP50				
Agency Approvals	CE, RoHS, cUL- _{US} (E189395)				
* Withstand voltage is good for power supply, signal, and case; not good for shield wire.					

Light Duty Incremental Encoders (Metric Dimension Encoders)

Specifications – TRD-MX series

Wiring Diagrams

Open Collector Connections

Cable shield is connected to the encoder body (frame ground)

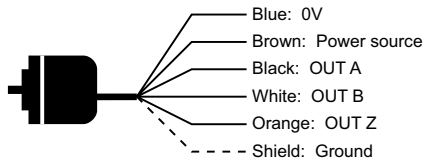

Line Driver Connections

Cable shield is connected to the encoder body (frame ground)

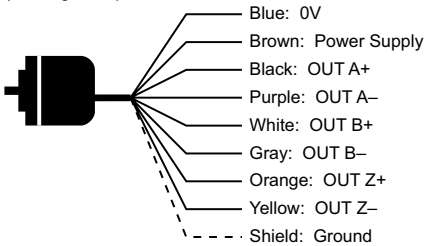

How to read the timing charts

Open Collector Models

Out A and Out B are 90 degrees out of phase. Like any quadrature encoder, four unique logic states are created internally to the encoder. This is based on the rising edge to rising edge (one cycle) on channel A or B that indicates one set of bars on the internal encoder disk has passed by the optical sensor.

OUT Z is the absolute reference added to an incremental encoder and is also known as home position. It signifies a full rotation of the encoder shaft. It pulses once per revolution.

Line Driver Models

Channel A (OUT A and A-not) and Channel B (OUT B and B-not) are also 90 degrees out of phase on line driver encoders. OUT Z is the same as on open collector models, and is the absolute reference (home position). It signifies one full rotation of the encoder shaft. It pulses once per revolution.

Channel Timing Charts

Open Collector Models (TRD-MXxxxAD/BD)

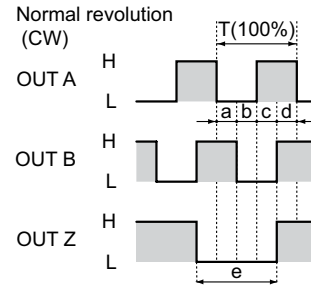

a, b, c, d = $0.25T \pm 0.125T$; e = $1T \pm 0.125T$
"Normal" means clockwise revolution viewed from the shaft

Line Driver Models (TRD-MXxxxVD)

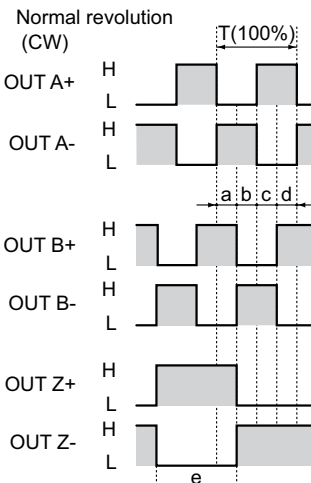

a, b, c, d = $0.25T \pm 0.125T$; e = $1T \pm 0.125T$
"Normal" means clockwise revolution viewed from the shaft

Dimensions – TRD-MX series

Dimensions = mm [in]

TRD-MXxxxD

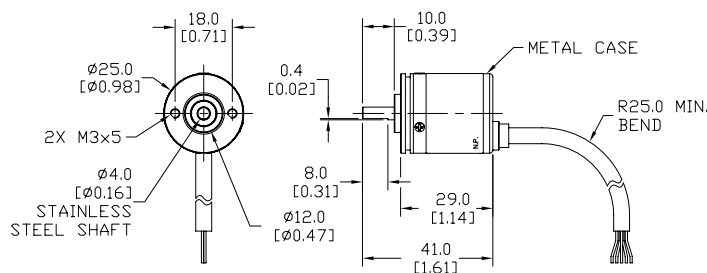

MM-4D Mounting Clamp

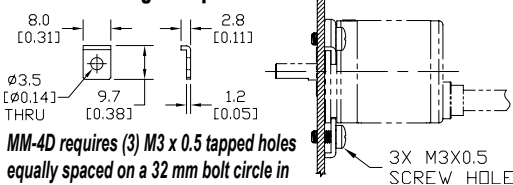

MM-4D requires (3) M3 x 0.5 tapped holes equally spaced on a 32 mm bolt circle in the mounting surface.

MT-030D Mounting Bracket

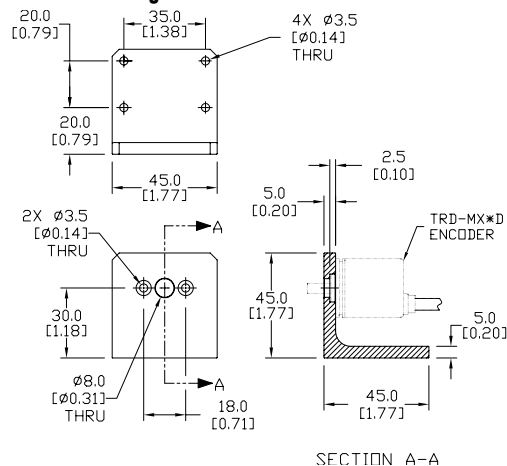

SECTION A-A

Light Duty Incremental Encoders (Metric Dimension Encoders)

TRD-S(H) series

Features

A light duty encoder that is cost-effective for small applications and has the following features:

- Small body with 38mm diameter and 30mm depth
- Dust proof (IP40 rating)
- 6mm solid shaft or 8mm hollow shaft
- Resolution available from 100 pulses per revolution to 2500 pulses per revolution
- Open collector or line driver output
- Up to 200 kHz response frequency
- Two-meter cable, tinned ends



Solid-shaft (TRD-S) model



Hollow-shaft (TRD-SH) model

Light Duty Solid Shaft Incremental Encoders (NPN Open Collector and Line Driver models)					
Part Number	Price	Pulses per Revolution	Input Voltage	Output	Body Diameter
TRD-S100AD	Retired	100	5-12 VDC	NPN open collector	38mm
TRD-S360AD	Retired	360			
TRD-S500AD	Retired	500			
TRD-S1000AD	Retired	1000			
TRD-S1024AD	Retired	1024			
TRD-S2500AD	Retired	2500			
TRD-S250BD	Retired	250	12-24 VDC	NPN open collector	
TRD-S300BD	Retired	300			
TRD-S600BD	Retired	600			
TRD-S1000-BD	Retired	1000			
TRD-S1024-BD	Retired	1024			
TRD-S1200BD	Retired	1200			
TRD-S100-VD	Retired	100	5 VDC	Line driver (differential)	
TRD-S250VD	Retired	250			
TRD-S300VD	Retired	300			
TRD-S400VD	Retired	400			
TRD-S800VD	Retired	800			
TRD-S1000-VD	Retired	1000			
TRD-S1200VD	Retired	1200			
TRD-S2500-VD	Retired	2500			

Light Duty Hollow Shaft Incremental Encoders (NPN Open Collector and Line Driver models)					
Part Number	Price	Pulses per Revolution	Input Voltage	Output	Body Diameter
TRD-SH100AD	Retired	100	5-12 VDC	NPN open collector	38mm
TRD-SH360AD	Retired	360			
TRD-SH500AD	Retired	500			
TRD-SH1000AD	Retired	1000			
TRD-SH1024AD	Retired	1024			
TRD-SH2500AD	Retired	2500			
TRD-SH400BD	Retired	400	12-24 VDC	NPN open collector	
TRD-SH500-BD	Retired	500			
TRD-SH600BD	Retired	600			
TRD-SH1000-BD	Retired	1000			
TRD-SH1200BD	Retired	1200			
TRD-SH2000BD	Retired	2000			
TRD-SH2500-BD	Retired	2500	5 VDC	Line driver (differential)	
TRD-SH100-VD	Retired	100			
TRD-SH200VD	Retired	200			
TRD-SH250VD	Retired	250			
TRD-SH300VD	Retired	300			
TRD-SH360-VD	Retired	360			
TRD-SH400VD	Retired	400			
TRD-SH500-VD	Retired	500			
TRD-SH600VD	Retired	600			
TRD-SH800VD	Retired	800			
TRD-SH1000-VD	Retired	1000			
TRD-SH1200VD	Retired	1200			
TRD-SH2000VD	Retired	2000			
TRD-SH2500-VD	Retired	2500			

Light Duty Incremental Encoders (Metric Dimension Encoders)

Specifications – TRD-S(H) series

Electrical Specifications					
Model		TRD-SxxxxAD TRD-SHxxxxAD (open collector)	TRD-Sxxxx-BD TRD-SHxxxxBD (open collector)	TRD-Sxxxx-VD TRD-SHxxxxVD (line driver)	
Power Supply	Operating Voltage *	5–12 VDC (nominal) * Range: 4.75–13.2 VDC	12–24 VDC (nominal) * Range: 10.8–26.4 VDC	5VDC (nominal) * Range: 4.75–5.25 VDC	
	Allowable Ripple	3% max.			
	Current Consumption	50 mA max.			
Signal Waveform		Quadrature + home position			
Max. Response Frequency		200 kHz			
Operating Speed		(max response frequency / resolution) x 60			
Duty Ratio		50% ±25%			
Phase Difference Width		25% ±12.5%			
Signal Width at Home Position		100 ±50%			
Output	Rise/Fall Time	1 µs max. (when cable length is 1m)		–	
	Output Type	NPN open collector output, sinking		Line driver output (26C31 or equivalent)	
	Output Logic	Negative logic (active low)		Negative logic (active high)	
	Output Voltage	H	–		2.5 V min.
		L	0.4 V max.		0.5 V max.
	Current	30 mA max.		20 mA max.	
	Load Power Voltage	35 VDC max.		–	
Short-Circuit Protection	Between output and power supply		–		
* To be supplied by Class II source					
Mechanical Specifications					
Starting Torque	0.001 Nm (0.00074 ft/lb) max				
Max. Allowable Shaft Load	Radial: 20N (4.5 lb); Axial: 10N (2.25 lb)				
Max. Allowable Speed	6000 rpm (highest speed that can support the mechanical integrity of encoder)				
Wire Size	AWG26				
Mounting Orientation	can be mounted in any orientation				
Weight	approx. 150g (5.3 oz) with 2m cable				
Environmental Specifications					
Ambient Temperature	-10 to +70 °C; 14 to 158 °F				
Storage Temperature	-25 to +85 °C; -13 to +185 °F				
Operating Humidity	35–85% RH				
Withstand Voltage	500 VAC (50/60Hz) for one minute				
Insulation Resistance	50 MΩ min.				
Vibration Resistance	durable for one hour along three axes at 10 to 55 Hz with 0.75 amplitude				
Shock Resistance	11 ms with 490 m/s ² applied three times along three axes				
Protection	IP40				

Light Duty Incremental Encoders (Metric Dimension Encoders)

Dimensions – TRD-S(H) series

Solid-shaft models

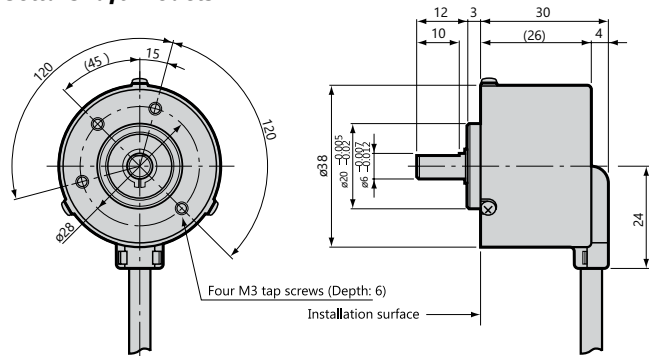

Hollow-shaft models

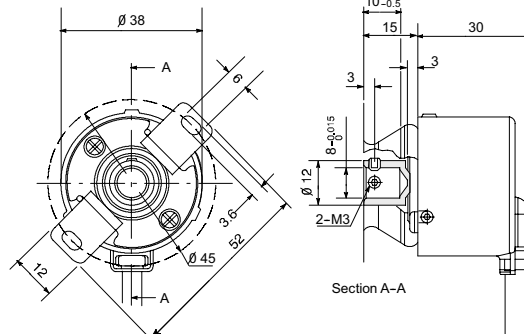

All dimensions in mm
1mm = 0.03937in

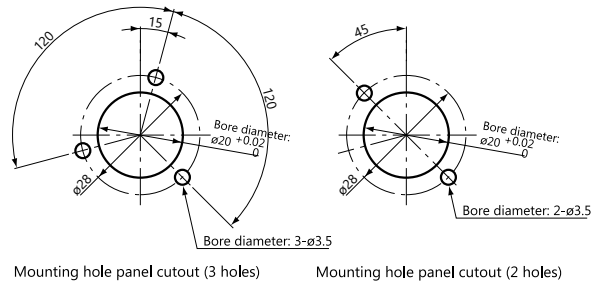

TRD-SH-BKT (bracket)

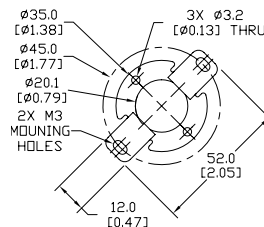

Mounting Accessories		
Part #	Price	Description
TRD-SH-BKT	\$7.00	JTEKT flexible mounting bracket, replacement, metal. For use with JTEKT TRD-SH series hollow shaft encoders.

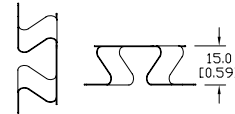

Wiring diagrams

Open collector connections

Cable shield is not connected to the encoder body; enclosure is grounded through the 0V wire

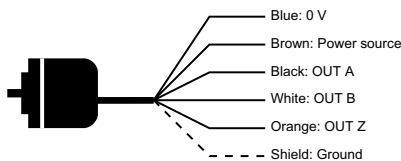

Line driver connections

Cable shield is not connected to the encoder body; enclosure is grounded through the 0V wire

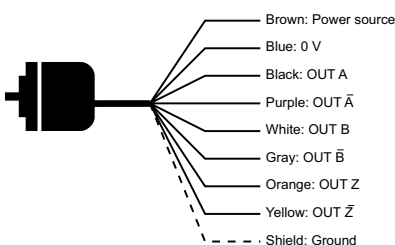

Channel timing charts

Open Collector Models

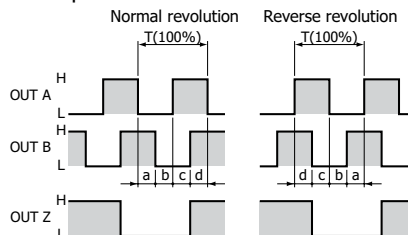

Line Driver Models

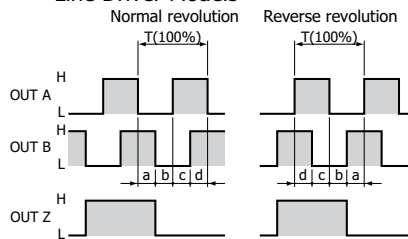

a, b, c, = $1/4T \pm 1/8T$
"Normal" means clockwise revolution viewed from the shaft.

How to read the timing charts

Open Collector Models

OUT A and Out B are 90 degrees out of phase. Like any quadrature encoder, four unique logic states are created internally to the encoder. This is based on the rising edge to rising edge (one cycle) on channel A or B that indicates one set of bars on the internal encoder disk has passed by the optical sensor.

OUT Z is the absolute reference added to an incremental encoder and is also known as home position. It signifies a full rotation of the encoder shaft.

Line Driver Models

Channel A (OUT A and A-not) and Channel B (OUT B and B-not) are also 90 degrees out of phase on line driver encoders. OUT Z is the same as on open collector models, and is the absolute reference (home position). It signifies one full rotation of the encoder shaft.

Encoder Accessories – Couplings

Encoder Couplings

Couplings provide a connection between solid-shaft encoders and solid shafts. We offer aluminum, fiberglass, and polymer couplings for metric, S.A.E. and metric-to-S.A.E. applications.

Misalignment compensation

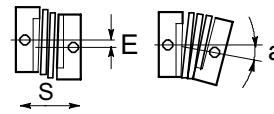

Couplings Selection Guide and Dimensions																
Type	Part Number	Price	Applicable Encoders (shaft size)	Shaft Diameter		D	L	F	C	M	a	E	S	Working Torque (N-m)	Torsional Rigidity	Material
				d1	d2	(mm [in])					max					
				(mm [in])												
Fiberglass (metric)	GJ-4D	\$13.00	TRD-MX (4mm)	4mm	4mm	13 [0.51]	21 [0.83]	5.3 [0.21]	3 [0.12]	M3 set screw	5°	0.4 [0.02]	0.4 [0.02]	0.6 N m	6 N m/rad	Glass-fiber reinforced resin
	GJ-6D	\$10.00	TRD-S/SR (6mm)	6mm	6mm	15 [0.59]	22 [0.87]	5.2 [0.20]	3 [0.12]	M3 set screw	6°	0.5 [0.02]	0.12 [0.005]	0.8 N m	10 N m/rad	
	GJ-8D	\$12.00	TRD-N/NA (8mm)	8mm	8mm	19 [0.75]	24 [0.94]	6.8 [0.27]	3.5 [0.14]	M4 set screw	5°	0.5 [0.02]	0.4 [0.016]	1.5 N m	20 N m/rad	
	GJ-10D	\$13.00	TRD-GK (10mm)	10mm	10mm	22 [0.87]	26 [1.02]	7.1 [0.28]	4 [0.16]	M4 set screw	5°	0.5 [0.02]	0.12 [0.005]	2.0 N m	32 N m/rad	
Fiberglass (SAE)	GJ-635D	\$24.00	TRDA-2E (0.25in)	0.25 in	0.25in	15 [0.59]	22 [0.87]	5.2 [0.20]	3 [0.12]	M3 set screw	5°	0.5 [0.02]	0.12 [0.005]	0.8 N m	10 N m/rad	Glass-fiber reinforced resin
	GJK-953D	\$30.00	TRDA-20/25 (0.375in)	0.375 in	0.375in	25 [0.98]	32 [1.26]	7.3 [0.29]	3.5 [0.14]	M4 set screw	5°	0.5 [0.02]	0.12 [0.005]	2.0 N m	32 N m/rad	
Polymer (SAE)	STP-MTRA-SC-1412	\$32.50	TRDA-2E (0.25in)	0.25 in	0.50in	25 [0.98]	38 [1.50]	9.9 [0.39]	5.4 [0.21]	M3 cap screw	5°	0.3 [0.01]	0.12 [0.005]	3.7 N m	0.36 °/lb in	Engineered polymer
	STP-MTRA-SC-3812	\$32.50	TRDA-20/25 (0.375in)	0.375in	0.50in	25 [0.98]	38 [1.50]	9.9 [0.39]	5.4 [0.21]	M3 cap screw	5°	0.3 [0.01]	0.12 [0.005]	3.7 N m	0.36 °/lb in	
Aluminum (metric)	ARM-075-5-4D	\$58.00	TRD-MX (4mm)	4mm	5mm	19.1 [0.75]	19.1 [0.75]	4.6 [0.18]	2.4 [0.09]	M3 set screw	5°	0.25 [0.01]	0.25 [0.01]	2.3 N m	8.2 N m/rad	Aluminum alloy
	RU-075D	\$66.00	TRD-S/SR (6mm)	6mm	6mm	19.1 [0.75]	19.1 [0.75]	4.6 [0.18]	2.4 [0.09]	M3 set screw	5°	0.25 [0.01]	0.12 [0.005]	1.0 N m	8.2 N m/rad	
	JU-100D	\$58.00	TRD-N/NA (8mm)	8mm	8mm	25.4 [1.00]	25.4 [1.00]	6.6 [0.26]	3.8 [0.15]	M5 set screw	5°	0.25 [0.01]	0.25 [0.01]	1.6 N m	14.3 N m/rad	
	RU-100D	\$68.00	TRD-GK (10mm)	10mm	10mm	25.4 [1.00]	25.4 [1.00]	6.6 [0.26]	3.8 [0.15]	M5 set screw	5°	0.25 [0.01]	0.12 [0.005]	1.6 N m	14.3 N m/rad	
Aluminum (metric-to-SAE)	ML13P-4-476D	\$57.00	TRD-MX (4mm)	4mm	0.1875in	13 [0.51]	19 [0.75]	5.5 [0.22]	2.5 [0.10]	M2 set screw	5°	0.4 [0.02]	0.2 [0.01]	0.25 N m	44 N m/rad	Aluminum alloy (Bent plate: Polyimide)
	ML16P-4-635D	\$56.00	TRD-MX (4mm) TRDA-2E (0.25in)	4mm	0.25in	16 [0.63]	23 [0.91]	7 [0.28]	3 [0.12]	M3 set screw	5°	0.6 [0.02]	0.3 [0.01]	0.4 N m	70 N m/rad	
	MCGL16-6-635	\$36.00	TRD-S/SR (6mm) TRDA-2E (0.25in)	6mm	0.25in	16 [0.63]	23.2 [0.91]	7 [0.28]	3 [0.12]	M3 set screw	3.5°	0.3 [0.01]	0.3 [0.01]	0.4 N m	70 N m/rad	
	MCGL20-8-635	\$47.50	TRD-N/NA (8mm) TRDA-2E (0.25in)	8mm	0.25in	20 [0.79]	26 [1.02]	7.5 [0.30]	3.7 [0.15]	M3 set screw	3.5°	0.3 [0.01]	0.4 [0.02]	0.6 N m	130 N m/rad	
	MCGL20-8-952	\$49.50	TRD-N/NA (8mm) TRDA-20/25 (0.375in)	8mm	0.375in	20 [0.79]	26 [1.02]	7.5 [0.30]	3.7 [0.15]	M3 set screw	3.5°	0.3 [0.01]	0.4 [0.02]	0.6 N m	130 N m/rad	
	MCGL25-10-635	\$60.00	TRD-GK (10 mm) TRDA-2E (0.25in)	10mm	0.25in	25 [0.98]	30.2 [1.19]	9 [0.35]	4 [0.16]	M4 set screw	3.5°	0.3 [0.01]	0.5 [0.02]	1.4 N m	240 N m/rad	
	MCGL25-10-952	\$61.00	TRD-GK (10 mm) TRDA-20/25 (0.375in)	10mm	0.375in	25 [0.98]	30.2 [1.19]	9 [0.35]	4 [0.16]	M4 set screw	3.5°	0.3 [0.01]	0.5 [0.02]	1.4 N m	240 N m/rad	
Aluminum (SAE)	ARM-075-635-635D	\$59.00	TRDA-2E (0.25in)	0.25in	0.25in	19.1 [0.75]	19.1 [0.75]	4.6 [0.18]	2.4 [0.09]	M3 set screw	5°	0.25 [0.01]	0.25 [0.01]	1.0 N m	8.2 N m/rad	Aluminum alloy
	ARM-100-9525-9525D	\$57.00	TRDA-20/25 (0.375in)	0.375in	0.375in	25.4 [1.00]	25.4 [1.00]	6.6 [0.26]	3.8 [0.15]	M5 set screw	5°	0.25 [0.01]	0.25 [0.01]	1.6 N m	14.3 N m/rad	

* mm ÷ 25.4 = inches

Encoder Accessories – Couplings

Encoder Couplings – Dimensions

GJ-xxD Fiberglass Couplings (metric) & GJx-xxxD Fiberglass Couplings (SAE)

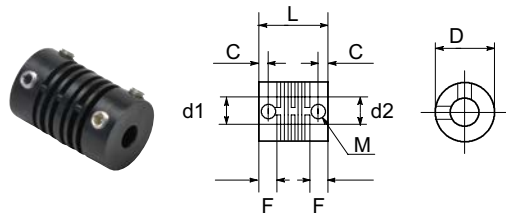

STP-MTRA-SC-xxxx Polymer Couplings

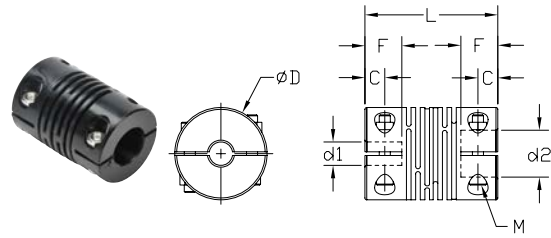

ARM-xxxxxxD Aluminum Couplings (metric & SAE)

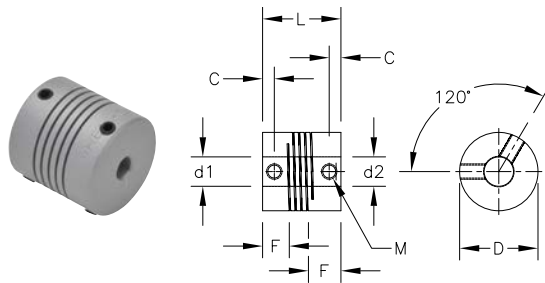

MCGLxx Aluminum Couplings & ML1xP-4-xxxD Aluminum Couplings

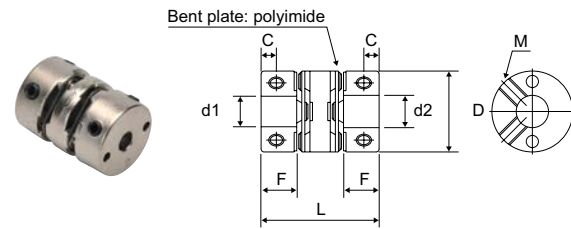

RU-075D, RU-100D, and JU-100D Aluminum Couplings

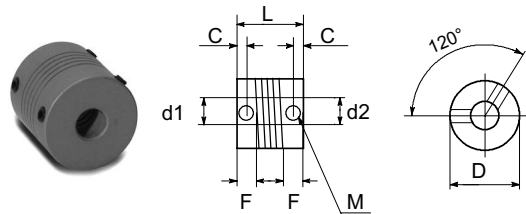

Encoder Selection Guide

SAE Dimension Encoders & Metric Dimension Encoders

Encoder Selection Guide												
Type	Duty	Series	Encoder Diameter	Shaft Diameter	Shaft Type	Operating Voltage (VDC) and Electrical Output	IP Rating	Cable	Max Radial Load (N)	Max Axial Load (N)	Available Resolutions (PPR)	Brand
Incremental	Modular Kit	AMT	28mm, 42mm	2, 3, 4, 5, 6, 8 mm 3/16, 1/4, 3/8, 1/2, 5/8 inch	Hollow	5V Line Driver (TTL) or 5V Push-Pull (Totem Pole)	IP20	Custom cables sold separately	N/A	N/A	Programmable up to 4096	Same Sky
		MTRA	31mm	5mm 1/4", 3/8"	Hollow	5V Line Driver (TTL) or 5V Push-Pull (Totem Pole)	IP20	Custom cables sold separately	N/A	N/A	400, 1000	SureStep
	Light Duty	TRD-S(H)R	38mm, 40mm	8mm	Solid or Hollow	5-30 VDC Universal output circuit: Push-Pull (Totem Pole), or NPN/PNP Open Collector (HTL), or Line Driver (TTL)	IP50 or IP65	Integral 2m pigtail cable	20	10	100, 200, 360, 500, 600, 1000, 1024, 2000, 2500	JTEKT
		A41	41mm	1/4"	Solid or Hollow		IP64	Integral 2m pigtail cable	20	20	100, 200, 360, 500, 1000, 1024, 200, 2048, 3600, 4096	Lika
	A50	50mm	1/4", 3/8"	Hollow	IP65		M12 cables sold separately	20	20	360, 1000, 1024, 2048		
	A80	80mm	30mm (reducer bushings available for 19 & 20mm, 5/8", 7/8", 1, and 1 1/8")	Hollow	IP64		M23 cables sold separately	30	30	1024		
	AQ58/59	58mm, 59mm	3/8" solid, 15mm hollow (reducer bushings available for 6, 8, 10, 11, 12 mm; 1/4, 3/8, 1/2 inch)	Solid or Hollow	IP65		M12 cables sold separately	100	100	Programmable from 1 to 16,384 (default 1024)		
	AR01	58mm	15mm	Solid Dual-shaft	IP65		M12 cables sold separately	50	50	250 (linear res: 0.36 deg/cts) 1250 (linear res: 0.072 deg/cts)		
	Medium Duty	TRDA-20	2"	3/8"	Solid	5VDC Line Driver (TTL) or 5-30 VDC Push-Pull (Totem Pole)	IP50	Integral 2m pigtail cable	50	30	100, 360, 500, 1000, 1024, 2500	JTEKT
		TRDA-25	2.5" flange (w/2.0" body)	3/8"	Solid		IP65	Military Spec (MS) cables sold separately	50	30	100, 360, 500, 1000, 1014, 2500	
		TRD-N(H)	50mm	8mm	Solid or Hollow		IP65	Integral 2m pigtail cable	50	30	3, 4, 5, 10, 30, 40, 50, 60, 100, 120, 200, 240, 250, 300, 360, 400, 480, 500, 600, 750, 1000, 1024, 1200, 2000, 2500	
		TRD-GK	78mm	10mm	Solid		10-30 VDC Push-Pull (Totem Pole)	IP65	Integral 2m pigtail cable	100	50	30, 100, 120, 200, 240, 250, 300, 360, 400, 500, 600, 1000, 1200, 2000, 2500, 3600, 5000
Absolute	Medium Duty	TRD-NA	50mm	8mm	Solid	10-30V NPN/PNP Open Collector (HTL)	IP65	Integral 2m pigtail cable	50	30	32, 64, 128, 180, 256, 360, 512, 720, 1024 (Gray code)	Lika
		AM5x ¹	58mm	6-15mm, 3/8"	Solid or Hollow	5-30 VDC, 10-30 VDC	IP65	M12 cables sold separately	40	40	Programmable up to 8192 ppr (13 bit), up to 16384 turns (14 bit)	

1 - AM5x encoders have different versions supporting 4 different outputs - Ethernet/IP, Modbus TCP, EtherCAT, and Modbus RTU (RS485).