

Drive Couplings

Drive Couplings Overview

Rotating shaft-driven mechanical components are commonly used in all forms of machinery that perform the various processes and functions of modern industry. Perfect alignment of shafts and rotating components is desired, but it is nearly impossible to build a real-world machine in which adjacent shaft ends align perfectly.

Adjacent shafts can be misaligned in 3 orientations, angular, parallel and axial, see figure below. Misalignment will place stresses on shafts and related parts of the assembly such as bearings, which can result in early failure of both.

Drive couplings can be used to compensate for shaft misalignment, whether the misalignment is an intentional or an unintentional part of the design. When designing or modifying a system, there are essential factors to consider for choosing the correct couplings for the application.

Design/Selection Factors:

(Refer to the specification tables herein for the particular specifications of each type of drive coupling.)

- **RPM:** For higher rpm applications, choose Jaw/Spider or Beam-Style Servo couplings. For lower rpm, consider Double-Loop or Oldham couplings.
- **Torque:** Consider the torque requirements of the application, and the torque specifications of the different drive coupling types. peak torque generally occurs at start-up, operating torque at steady-state operation, and reversing or braking torque during rapid acceleration or deceleration or direction changes.
- **Backlash:** Backlash is a measurement of the positional accuracy of the coupling, which is important for reversing and/or motion control applications. Zero backlash is ultimately desirable, but more expensive than necessary for low-precision applications.

For high-precision applications, choose Beam-Style Servo or Oldham couplings. For applications requiring less precision, consider Jaw/Spider or Double-Loop couplings.

- **Misalignment:** Some degree of angular, axial, or radial misalignment/displacement between shafts is almost unavoidable. Drive couplings can compensate for this misalignment.

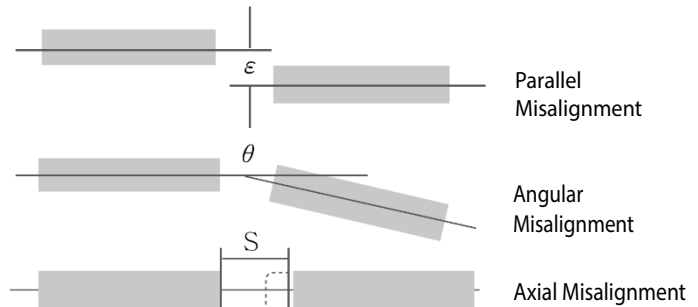

Coupling Type Comparisons				
Coupling Type	Jaw / Spider	Double Loop	Oldham	Beam-Style Servo
Representative Photo				
Purpose	most common	light duty	general purpose	high performance & torque
Hub Material	aluminum	stainless steel	aluminum	416 stainless steel
Center Material	polyurethane	Hytrel™	Delrin™	420 stainless steel
Mounting Method	clamp	set screw	clamp	set screw
Electrical Isolation	yes	yes	yes	no
Backlash	varies	varies	zero	zero
Misalignment Capacity	++ (axial)	+++	++	+
Breakable "Mechanical Fuse"	no (fail safe)	no	yes	no
Relative Price	\$\$	\$\$	\$	\$\$\$

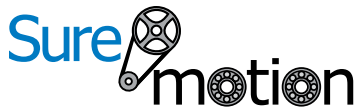

Drive Couplings

Jaw/Spider Clamp-Style Couplings



Features

- Most commonly specified coupling type
- Aluminum hubs available with different bore diameters in same coupling
- Polyurethane center “spiders” available in different durometers for different degrees of shock and vibration reduction
- Fail-safe operation
- Electrical isolation
- Wide torque range
- High axial misalignment range
- Cost effective
- Wide operating temperature range: -40 to 100 °C (-40 to 212 °F)

Applications

- General applications
- High-speed applications
- Applications with high axial misalignment
- Applications in which inertia is NOT a factor

Jaw / Spider Aluminum Clamp-Style Drive Coupling Hubs*															
Part Number*	Price	Size (mm)	Bore	Max RPM	Torque	Torsional Stiffness	Max Misalignment			Weight (lb)					
							Parallel (in [mm])	Axial (in [mm])	Angular						
DC-JAC14-03	\$12.50	14	3/16in	27,280	The torque and torsional stiffness of the assembly varies depending upon which center “spider” is used. Refer to the “Jaw / Spider Drive Coupling Spiders” table (page tPTR-52) for torque and torsional stiffness specifications.	0.002 [0.05]	0.030 [0.76]	1.0°	0.039						
DC-JAC14-05M	\$12.50		5mm												
DC-JAC14-06M	\$12.50		6mm												
DC-JAC14-04	\$12.50		1/4in												
DC-JAC20-04	\$16.00	20	1/4in	19,040					0.008 [0.2]	0.050 [1.27]	1.2°	0.058			
DC-JAC20-05	\$16.00		5/16in												
DC-JAC30-05	\$23.50	30	5/16in	12,720								0.009 [0.23]	0.060 [1.52]	0.9°	0.070
DC-JAC30-08M	\$23.50		8mm												
DC-JAC30-06	\$23.50		3/8in												
DC-JAC30-10M	\$23.50		10mm												
DC-JAC30-12M	\$23.50		12mm												
DC-JAC30-08	\$23.50	1/2in													
DC-JAC40-08M	\$27.50	40	8mm	11,200		0.009 [0.23]	0.060 [1.52]	0.9°							0.145
DC-JAC40-06	\$27.50		3/8in												
DC-JAC40-10M	\$27.50		10mm												
DC-JAC40-12M	\$27.50		12mm												
DC-JAC40-08	\$27.50		1/2in												
DC-JAC40-14M	\$27.50		14mm												
DC-JAC40-10	\$27.50		5/8in												
DC-JAC40-16M	\$27.50		16mm												
DC-JAC40-12	\$27.50	3/4in													
DC-JAC55-10	\$32.00	55	5/8in	8,480	0.009 [0.23]				0.060 [1.52]	0.9°	0.383				
DC-JAC55-19M	\$30.50		19mm												
DC-JAC55-12	\$32.00		3/4in												
DC-JAC55-22M	\$32.00		22mm												
DC-JAC55-14	\$32.00	7/8in													
DC-JAC65-20	\$52.00	65	1-1/4in	6,800		0.009 [0.23]	0.060 [1.52]	0.9°			0.683				
DC-JAC65-32M	\$52.00		32mm												

* A complete jaw/spider coupling assembly consists of two hubs and one spider, each of the same “size” and each purchased separately. The two hubs can be of different “bore” diameters, if needed for the application.



Drive Couplings

Jaw/Spider Clamp-Style Coupling Spiders



Jaw / Spider Drive Coupling Spiders*								
Part Number*	Price	Size	Durometer	Color	Torque (lb-in [N-m])			Torsional Stiffness (lb-in/rad [Nm/rad])
					Rated	Max	Reversing**	
DC-JS14-80A	\$7.25	14	80A	blue	6 [0.7]	12 [1.4]	2 [0.2]	71 [8]
DC-JS14-92A	\$7.25		92A	white	11 [1.2]	21 [2.4]		124 [14]
DC-JS14-98A	\$7.25		98A	red	18 [2.0]	35 [4.0]		195 [22]
DC-JS20-80A	\$10.50	20	80A	blue	16 [1.8]	32 [3.6]	4 [0.5]	142 [16]
DC-JS20-92A	\$10.50		92A	white	27 [3.1]	53 [6.0]		257 [29]
DC-JS20-98A	\$10.50		98A	red	44 [5.0]	89 [10.1]		487 [55]
DC-JS30-80A	\$12.00	30	80A	blue	35 [4.0]	71 [8.0]	9 [1.0]	407 [46]
DC-JS30-92A	\$12.00		92A	white	66 [7.5]	133 [15.0]		646 [73]
DC-JS30-98A	\$12.00		98A	red	111 [12.5]	221 [25.0]		1151 [130]
DC-JS40-80A	\$13.00	40	80A	blue	43 [4.9]	86 [9.7]	11 [1.2]	3363 [380]
DC-JS40-92A	\$13.00		92A	white	88 [9.9]	177 [20.0]		5045 [570]
DC-JS40-98A	\$13.00		98A	red	150 [16.9]	300 [33.9]		10621 [1200]
DC-JS55-80A	\$14.50	55	80A	blue	151 [17.1]	301 [34.0]	39 [4.4]	12391 [1400]
DC-JS55-92A	\$14.50		92A	white	310 [35.0]	620 [70.1]		14161 [1600]
DC-JS55-98A	\$14.50		98A	red	530 [59.9]	1060 [119.8]		23012 [2600]
DC-JS65-80A	\$18.50	65	80A	blue	407 [46.0]	814 [92.0]	106 [12.0]	24782 [2800]
DC-JS65-92A	\$18.50		92A	white	840 [94.9]	1680 [189.8]		26552 [3000]
DC-JS65-98A	\$18.50		98A	red	1415 [159.9]	2830 [319.7]		43369 [4900]

* A complete jaw/spider coupling assembly consists of two hubs and one spider, each of the same "size" and each purchased separately. The two hubs can be of different "bore" diameters, if needed for the application.

** Reversing Torque is the rapid reversal of rotation and has a lower value to account for stopping inertia and driving in the opposite rotation. For slow direction reversals, Nominal Torque applies.

Dimensions (in [mm])

Jaw / Spider Drive Coupling Hub Bore Dimensions

Hubs	Sizes	ØB
DC-JACxx-03	14	3/16 in
DC-JACxx-05M	14	5mm
DC-JACxx-06M	14	6mm
DC-JACxx-04	14, 20	1/4 in
DC-JACxx-05	20, 30	5/16 in
DC-JACxx-08M	30, 40	8mm
DC-JACxx-06	30, 40	3/8 in
DC-JACxx-10M	30, 40	10mm
DC-JACxx-12M	30, 40	12mm
DC-JACxx-08	30, 40	1/2 in
DC-JACxx-14M	40	14mm
DC-JACxx-10	40, 55	5/8 in
DC-JACxx-16M	40	16mm
DC-JACxx-12	40, 55	3/4 in
DC-JACxx-19M	55	19mm
DC-JACxx-22M	55	22mm
DC-JACxx-14	55	7/8 in
DC-JACxx-20	65	1-1/4 in
DC-JACxx-32M	65	32mm

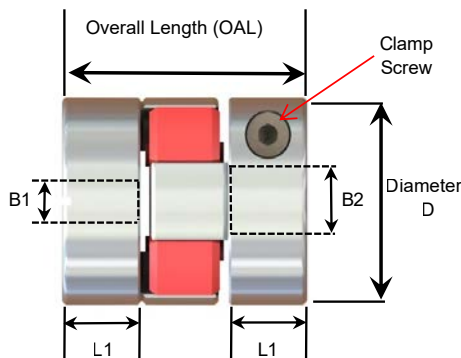

Jaw / Spider Aluminum Clamp-Style Drive Coupling Assembly Dimensions*

Size	Components	Clamp Screw	L1	OAL	D
			in [mm]		
14	(2) DC-JAC14-xxx + (1) DC-JS14-xxx	#4-40	0.28 [7.1]	0.86 [21.8]	0.55 [14.0]
20	(2) DC-JAC20-xxx + (1) DC-JS20-xxx	#5-40	0.39 [9.9]	1.20 [30.5]	0.78 [19.8]
30	(2) DC-JAC30-xxx + (1) DC-JS30-xxx	#6-32	0.43 [10.9]	1.35 [34.3]	1.18 [30.0]
40	(2) DC-JAC40-xxx + (1) DC-JS40-xxx	#10-24	0.98 [24.9]	2.55 [64.8]	1.57 [39.9]
55	(2) DC-JAC55-xxx + (1) DC-JS55-xxx	1/4-20	1.16 [29.5]	2.97 [75.4]	2.17 [55.1]
65	(2) DC-JAC65-xxx + (1) DC-JS65-xxx	5/16-18	1.40 [35.6]	3.53 [89.7]	2.55 [64.8]

* Assembly dimensions are for any (2) hubs + (1) spider of the same "size" as assembled. B1 & B2 are the Bore sizes for the selected DC-JACxx Jaw/Hub.

See our website: www.AutomationDirect.com for complete Engineering drawings.

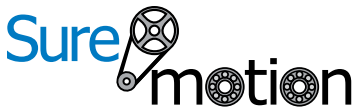

Drive Couplings

Double Loop Couplings

Features

- High torsional rigidity
- One-piece design
- Hubs made of series 300 stainless steel
- Double loop made of DuPont Hytrel™
- Corrosion protection
- Outstanding resistance to acids, alkalis, solvents, oils, grease, ozone
- Wide operating temperature range: -40 to 100 °C (-40 to 212 °F)
- Electrical isolation
- Damping of shock and vibration
- Speeds up to 3,000rpm

Applications

- Light-duty applications
- Medium-speed applications
- Applications in which inertia is NOT a factor



Double Loop Stainless Steel Drive Couplings									
Part Number	Price	Size	Bore	Max rpm	Max Torque @ Max Displacement ([lb-in] N-m)	Max Misalignment			Weight (lb)
						Radial ([in] mm)	Axial ([in] mm)	Angular (°)	
DC-DLSS10-02	\$40.00	10	1/8 in	3,000	[4.4] 0.5	[0.10] 2.6	[0.18] 4.5	10	0.06
DC-DLSS10-03	\$40.00		3/16 in						
DC-DLSS10-06M	\$40.00		6mm						
DC-DLSS10-04	\$40.00		1/4 in						
DC-DLSS10-05	\$40.00		5/16 in						
DC-DLSS10-08M	\$40.00		8mm						
DC-DLSS20-04	\$44.50	20	1/4 in	3,000	[15.9] 1.8	[0.30] 7.5	15	0.20	
DC-DLSS20-05	\$44.50		5/16 in						
DC-DLSS20-08M	\$44.50		8mm						
DC-DLSS20-06	\$44.50		3/8 in						
DC-DLSS20-12M	\$44.50		12mm						
DC-DLSS20-08	\$44.50		1/2 in						
DC-DLSS30-12M	\$49.50	30	12mm	3,000	[44.3] 5.0	[0.13] 3.2	15	0.27	
DC-DLSS30-08	\$49.50		1/2 in						
DC-DLSS30-14M	\$49.50		14mm						
DC-DLSS30-10	\$49.50		5/8 in						
DC-DLSS40-08	\$55.00	40	1/2 in	3,000	[88.5] 10.0	[0.43] 11.0	15	0.30	
DC-DLSS40-14M	\$55.00		14mm						
DC-DLSS40-10	\$55.00		5/8 in						
DC-DLSS40-16M	\$55.00		16mm						

Dimensions (in [mm])

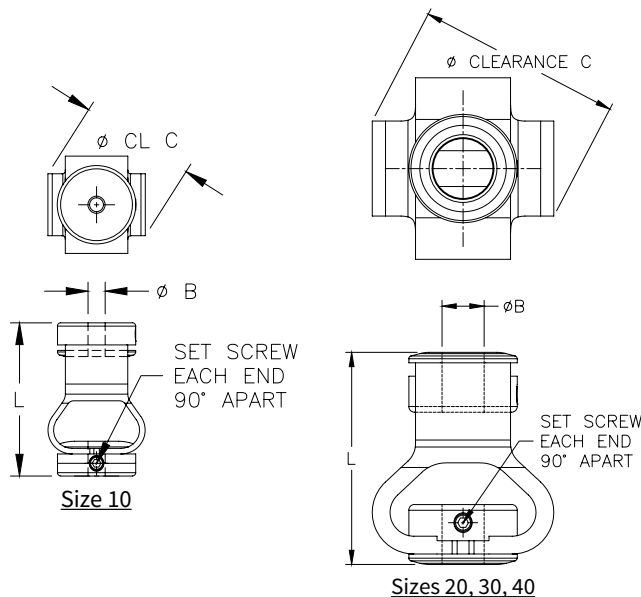

Double Loop Stainless Steel Drive Coupling Dimensions					
Part Number	Size	Set Screw	ØB	ØC L	
				(in [mm])	
DC-DLSS10-02	10	M3	1/8 in	1.06 [26.9]	
DC-DLSS10-03			3/16 in		
DC-DLSS10-06M			6mm		
DC-DLSS10-04			1/4 in		
DC-DLSS10-05			5/16 in		
DC-DLSS10-08M			8mm		
DC-DLSS20-04	20	M4	1/4 in	1.89 [48.0]	
DC-DLSS20-05			5/16 in		
DC-DLSS20-08M			8mm		
DC-DLSS20-06			3/8 in		
DC-DLSS20-12M			12mm		
DC-DLSS20-08			1/2 in		
DC-DLSS30-12M	30	M5	12mm	2.13 [54.1]	2.17 [55.1]
DC-DLSS30-08			1/2 in		
DC-DLSS30-14M			14mm		
DC-DLSS30-10			5/8 in		
DC-DLSS40-08	40	M6	1/2 in	2.20 [55.9]	2.20 [55.9]
DC-DLSS40-14M			14mm		
DC-DLSS40-10			5/8 in		
DC-DLSS40-16M			16mm		

See our website: www.AutomationDirect.com for complete Engineering drawings.

Suremotion Drive Couplings

Oldham Drive Couplings



Features

- Large radial misalignment capability
- Hubs made of aluminum 2011 T8
- Center discs made of Delrin™
- Mechanical 'fuse' prevents damage to other components in over-torque conditions
- Zero backlash
- Corrosion-resistant
- Non-magnetic
- Operating temperature range: -20 to 60 °C (-4 to 140 °F)

- Electrical isolation
- Absorbs shock and isolates vibration
- Dampens resonance
- Speeds up to 3,000rpm
- Low inertia

Applications

- General-purpose applications
- Medium-speed applications

Oldham Aluminum Clamp-Style Drive Coupling Hubs*

Part Number*	Price	Size	Bore	Max rpm	Torque (lb-in [N·m])		Max Offset			Moment of Inertia (lb-in·s ² ×10 ⁻⁵)	Weight (lb)
					Peak	Static Break	Radial (in [mm])	Axial (in [mm])	Angular (°)		
DC-DAC19-05M	\$17.50	19	5mm	3,000	15 [1.7]	71 [8.0]	0.016 [0.41]	0.004 [0.1]	1.5	0.518	0.032
DC-DAC19-04	\$17.50		1/4 in								0.032
DC-DAC19-08M	\$17.50		8mm								0.033
DC-DAC25-04	\$24.00	25	1/4 in	3,000	35 [4.0]	115 [13.0]	0.016 [0.41]	0.004 [0.1]	2.23	0.055	
DC-DAC25-08M	\$24.00		8mm							0.054	
DC-DAC25-06	\$24.00		3/8 in							0.050	
DC-DAC25-10M	\$24.00		10mm							0.050	
DC-DAC25-12M	\$24.00		12mm							0.051	
DC-DAC33-06	\$34.50	33	3/8 in	3,000	80 [9.0]	465 [52.5]	0.016 [0.41]	0.006 [0.15]	10.0	0.097	
DC-DAC33-10M	\$28.00		10mm							0.095	
DC-DAC33-12M	\$34.50		12mm							0.095	
DC-DAC33-08	\$34.50		1/2 in							0.093	
DC-DAC33-14M	\$34.50		14mm							0.091	
DC-DAC33-10	\$30.00		5/8 in							0.088	
DC-DAC33-16M	\$18.50		16mm							0.087	
DC-DAC41-08	\$38.00	41	1/2 in	3,000	150 [16.9]	500 [56.5]	0.020 [0.51]	0.006 [0.15]	3	0.186	
DC-DAC41-14M	\$38.00		14mm							0.181	
DC-DAC41-10	\$38.00		5/8 in							0.177	
DC-DAC41-16M	\$38.00		16mm							0.172	
DC-DAC41-19M	\$38.00		19mm							0.168	
DC-DAC41-12	\$38.00	3/4 in	0.163								
DC-DAC50-08	\$78.00	50	1/2 in	3,000	265 [29.9]	840 [94.9]	0.020 [0.51]	0.008 [0.2]	66.7	0.260	
DC-DAC50-14M	\$78.00		14mm							0.255	
DC-DAC50-10	\$78.00		5/8 in							0.249	
DC-DAC50-16M	\$78.00		16mm							0.244	
DC-DAC50-19M	\$78.00		19mm							0.238	
DC-DAC50-12	\$78.00		3/4 in							0.233	
DC-DAC50-16	\$78.00	1 in	0.227								
DC-DAC57-10	\$85.00	57	5/8 in	3,000	390 [44.1]	1325 [149.7]	0.020 [0.51]	0.008 [0.2]	109.7	0.457	
DC-DAC57-16M	\$85.00		16mm							0.439	
DC-DAC57-19M	\$85.00		19mm							0.422	
DC-DAC57-12	\$85.00		3/4 in							0.404	
DC-DAC57-16	\$85.00	1 in	0.386								

* A complete Oldham coupling assembly consists of two hubs and one torque disc, each of the same "size" and each purchased separately. The two hubs can be of different "bore" diameters, if needed for the application.

Suremotion Drive Couplings

Oldham Drive Couplings



Oldham Aluminum Clamp-Style Drive Coupling Torque Discs*			
Part Number *	Price	Size	Color
DC-DDS19	\$2.00	19	black
DC-DDS25	\$4.25	25	
DC-DDS33	\$8.50	33	
DC-DDS41	\$9.25	41	
DC-DDS50	\$21.00	50	
DC-DDS57	\$29.00	57	

* A complete Oldham coupling assembly consists of two hubs and one torque disc, each of the same "size" and each purchased separately. The two hubs can be of different "bore" diameters, if needed for the application.

Dimensions (in [mm])

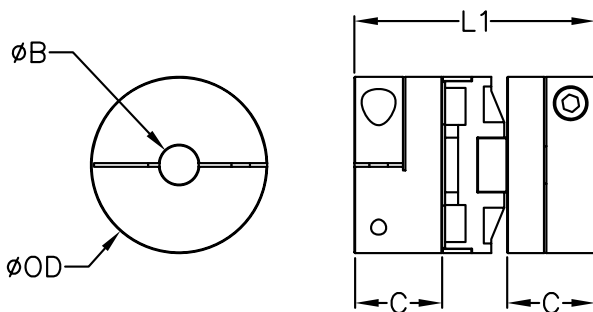

Oldham Aluminum Drive Coupling Hub Bore Dimensions		
Hubs	Sizes	ØB
DC-DACxx-05M	19	5mm
DC-DACxx-04	19, 25	1/4 in
DC-DACxx-08M	19, 25	8mm
DC-DACxx-06	25, 33	3/8 in
DC-DACxx-10M	25, 33	10mm
DC-DACxx-12M	25, 33	12mm
DC-DACxx-08	33, 41, 50	1/2 in
DC-DACxx-14M	33, 41, 50	14mm
DC-DACxx-10	33, 41, 50, 57	5/8 in
DC-DACxx-16M	33, 41, 50, 57	16mm
DC-DACxx-12	41, 50, 57	3/4 in
DC-DACxx-19M	41, 50, 57	19mm
DC-DACxx-16	50, 57	1in

Oldham Aluminum Clamp-Style Drive Coupling Assembly Dimensions*					
Size	Components	Cap Screw	C	L1**	ØOD
			(in [mm])		
19	(2) DC-DAC19-xxx + (1) DC-DDS19	#4-40	0.37 [9.4]	1.02 [25.9]	0.75 [19.1]
25	(2) DC-DAC25-xxx + (1) DC-DDS25	M3	0.46 [11.7]	1.28 [32.5]	1.00 [25.4]
33**	(2) DC-DAC33-xxx + (1) DC-DDS33	M4	0.59 [15.0]	1.89 [48.0]	1.31 [33.3]
41	(2) DC-DAC41-xxx + (1) DC-DDS41	M4	0.70 [17.8]	2.00 [50.8]	1.63 [41.4]
50	(2) DC-DAC50-xxx + (1) DC-DDS50	M5	0.81 [20.6]	2.35 [59.7]	1.97 [50.0]
57	(2) DC-DAC57-xxx + (1) DC-DDS57	M6	1.12 [28.4]	3.07 [78.0]	2.25 [57.2]

* Assembly dimensions are for any (2) hubs + (1) torque disc of the same "size" as assembled. Among components of the same "size," the only dimension that varies is the hub bore diameter (ØB), which is shown separately.

** When DC-DAC33-08 is used with another DC-DAC33-xx bore size, L1 = 45. When 2 DC-DAC33-08 are used together, L1 = 42

See our website: www.AutomationDirect.com for complete Engineering drawings.



Drive Couplings

Beam-Style Servo Stainless Steel Set-Screw Couplings



Features

- Flexibility of bellows coupling plus torsional stiffness and strength of disc coupling
- Hubs made of 416 stainless steel
- Flex beams made of 420 stainless steel
- Zero backlash
- Corrosion-resistant
- Bore reducers available to fit a wide variety of bore combinations
- Very wide operating temperature range:
 - for 24/7 applications: -73 to 191 °C (-100 to 375 °F)
 - for intermittent applications (<8hr): -73 to 232 °C (-100 to 450 °F)

- Speeds up to 10,000rpm
- Torque up to 300 lb-in

Applications

- High performance applications
- High-speed applications
- High-torque applications

Beam-Style Servo Stainless Steel* Set-Screw Drive Coupling Hubs											
Part Number	Price	Size	Bore**	Max rpm	Torsional Stiffness (lb-in/°)	Max Torque (lb-in [N-m])	Max Misalignment			Moment of Inertia (lb-in-s ² x10 ⁻⁵)	Weight (oz)
							Radial (in [mm])	Axial (in [mm])	Angular (°)		
DC-SBS19-0404	\$49.50	19	1/4 in	10,000	11	12 [1.4]	0.010 [0.25]	0.020 [0.51]	7	0.86	0.84
DC-SBS25-0808	\$61.00	25	1/2 in	7,500	27	24 [2.7]				0.015 [0.38]	0.025 [0.64]
DC-SBS32-1010	\$67.00	32	5/8 in		5,000	51	48 [5.4]	0.020 [0.51]	0.030 [0.76]		
DC-SBS38-1212	\$77.00	38	3/4 in	89		75 [8.5]	0.040 [1.02]			0.050 [1.27]	28.2
DC-SBS44-1414	\$132.00	44	7/8 in	135	135 [15.3]	0.025 [0.64]		0.060 [1.52]	59.2		7.59
DC-SBS51-1616	\$154.00	51	1 in	205	180 [20.3]		349		115	11.26	
DC-SBS63-2020	\$177.00	63	1-1/4 in	3,750	395	300 [33.9]		349	18.67		

* Hubs are 416 stainless; flex beams are 420 stainless.

** Bore Reducers can be purchased separately from AutomationDirect and installed in DC-SBSxx-xxxx hubs if different bore sizes are needed. (See page tPTR-57 for Bore Reducers.)

Dimensions (in [mm])

Beam-Style Servo Stainless Steel Drive Coupling Dimensions						
Size	Set Screw	L	L1	ØB1*	ØB2*	ØOD
(in [mm])						
19	M3x0.5	0.75 [19.1]	0.240 [6.10]	0.250 [6.35]	0.75 [19.1]	0.75 [19.1]
25		1.00 [25.4]	0.345 [8.76]	0.500 [12.70]	1.00 [25.4]	1.00 [25.4]
32	M5x0.8	1.25 [31.6]	0.386 [9.80]	0.625 [15.88]	1.25 [31.6]	1.25 [31.6]
38		1.50 [38.1]	0.505 [12.83]	0.750 [19.05]	1.50 [38.1]	1.50 [38.1]
44		1.75 [44.5]	0.550 [13.97]	0.875 [22.23]	1.75 [44.5]	1.75 [44.5]
51		2.00 [50.8]	0.555 [14.10]	1.000 [25.40]	2.00 [50.8]	2.00 [50.8]
63	M6x1.0	2.50 [63.5]	0.615 [15.62]	1.250 [31.75]	2.50 [63.5]	2.50 [63.5]

* Use bore reducers for additional bore sizes and bore combinations.

See our website: www.AutomationDirect.com for complete Engineering drawings.

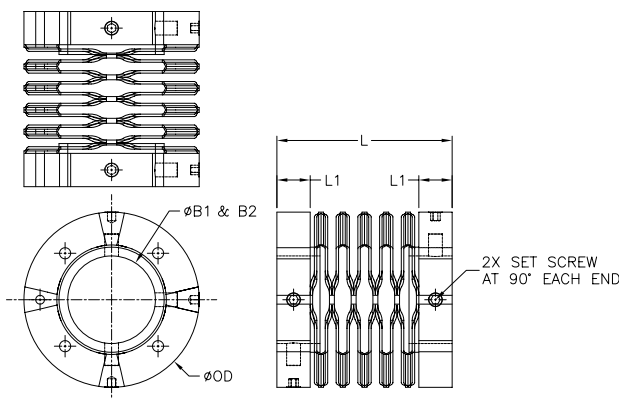

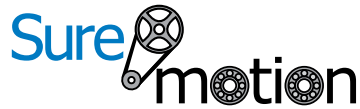

Drive Couplings

Accessories – Bore Reducers



Features

- For use in all SureMotion drive coupling hubs to reduce bore size
- Split-collar design with 2 set screw flats will not mark shaft
- 25% greater holding power than standard split collar
- Hardened stainless steel

Bore Reducers – Stainless Steel Clamping Type						
Part Number	Price	Outside Diameter		Inside Diameter		Length
		Nominal	Actual	Nominal	Actual	
DC-BRS04-02	\$8.25	1/4 in	0.250 in	1/8 in	0.125 in	0.221 in
DC-BRS04-04M	\$8.25			4mm	4mm	
DC-BRS04-03	\$8.25			3/16 in	0.1875 in	
DC-BRS04-05M	\$8.25			5mm	5mm	
DC-BRS08-06M	\$11.00	1/2 in	0.500 in	6mm	6mm	0.449 in
DC-BRS08-04	\$11.00			1/4 in	0.25 in	
DC-BRS08-05	\$11.00			5/16 in	0.3125 in	
DC-BRS08-08M	\$11.00			8mm	8mm	
DC-BRS08-06	\$11.00			3/8 in	0.375 in	
DC-BRS08-10M	\$11.00			10mm	10mm	
DC-BRS10-10M	\$12.50	5/8 in	0.625 in	10mm	10mm	0.460 in
DC-BRS10-07	\$12.50			7/16 in	0.4375 in	
DC-BRS10-12M	\$12.50			12mm	12mm	
DC-BRS10-08	\$12.50			1/2 in	0.5 in	
DC-BRS10-14M	\$12.50			14mm	14mm	
DC-BRS10-09	\$12.50			9/16 in	0.5625 in	
DC-BRS12-06	\$15.00	3/4 in	0.750 in	3/8 in	0.375 in	0.646 in
DC-BRS12-12M	\$15.00			12mm	12mm	
DC-BRS12-08	\$15.00			1/2 in	0.5 in	
DC-BRS12-10	\$15.00			5/8 in	0.625 in	
DC-BRS12-16M	\$15.00			16mm	16mm	
DC-BRS12-11	\$15.00			11/16 in	0.6875 in	
DC-BRS14-14M	\$16.00	7/8 in	0.875 in	14mm	14mm	0.755 in
DC-BRS14-10	\$16.00			5/8 in	0.625 in	
DC-BRS14-16M	\$16.00			16mm	16mm	
DC-BRS14-11	\$16.00			11/16 in	0.6875 in	
DC-BRS14-18M	\$16.00			18mm	18mm	
DC-BRS14-12	\$16.00			3/4 in	0.75 in	
DC-BRS16-10	\$16.50	1 in	1.000 in	5/8 in	0.625 in	0.773 in
DC-BRS16-18M	\$16.50			18mm	18mm	
DC-BRS16-12	\$16.50			3/4 in	0.75 in	
DC-BRS16-20M	\$16.50			20mm	20mm	
DC-BRS16-13	\$16.50			13/16 in	0.8125 in	
DC-BRS16-14	\$16.50			7/8 in	0.875 in	
DC-BRS20-22M	\$17.00	1-1/4 in	1.250 in	22mm	22mm	0.793 in
DC-BRS20-24M	\$17.00			24mm	24mm	
DC-BRS20-25M	\$17.00			25mm	25mm	
DC-BRS20-16	\$17.00			1 in	1.0 in	
DC-BRS20-17	\$17.00			1-1/16 in	1.0625 in	
DC-BRS20-18	\$17.00			1-1/8 in	1.125 in	