

Relay Output Modules

F3-08TRS-1 Relay Output \$298.00	
Outputs per Module	8
Commons per Module	8 (isolated)
Operating Voltage*	12-125 VAC 125-250 VAC (requires external fuses) 12-30 VDC
Output Type	6 Form A (SPST), 2 Form C (SPDT)
Max Current (resistive)	10A/point AC/DC, 32A/module AC/DC*
Max leakage Current	N/A
Max Inrush Current	10A inductive
Minimum Load	100 mA @ 12 VDC
Base Power Required	9V 37 mA/ON pt., (296 mA max), 24V N/A
OFF to ON Response	13 ms max
ON to OFF Response	9 ms max
Terminal Type	Removable
Status Indicators	Logic side
Weight	8.9 oz. (252g)
Fuses	8 fuses (10A, 125V), Non-replaceable
Peak Voltage	265 VAC/120 VDC
AC Frequency	47-63 Hz
ON Voltage Drop	N/A

Typical Relay Life			
Max. Resistive or Inductive Inrush Load Current	Operating Voltage		
	28 VDC	120 VAC	240 VAC
1/4HP		25K	
10.0 A	50K	50K	
5.0 A	200K	100K	
3.0 A	325K	125K	50K
0.5 A	> 50M		

See page tDL3-26 for part numbers of ZIPLink cables and connection modules compatible with this I/O module.



Note: When used with the ZIPLink wiring system, relay outputs are derated not to exceed 2 Amps per point max.

* Caution: the ZIPLink wiring system is rated at 2 Amps per I/O point and 4 Amps per common, therefore the F3-08TRS-1 relay outputs are derated to 2 Amps per point and 4 Amps per common when used with the ZIPLink wiring system.
 Note: Maximum DC voltage rating is 120 VDC at 0.5 Amp, 30,000 cycles typical.
 Motor starters up to and including NEMA size 4 can be used with this module.

Derating Chart

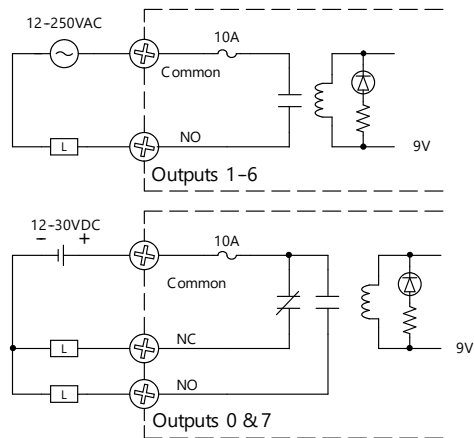
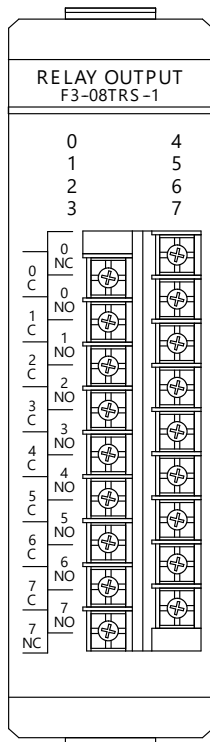
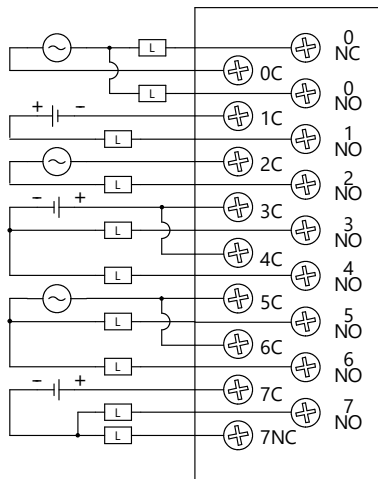
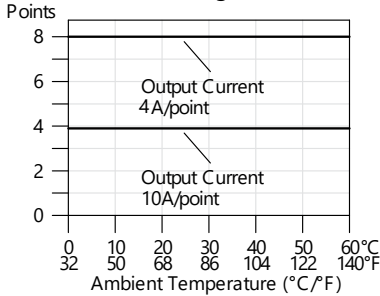

* Caution: the ZIPLink wiring system is rated at 2 Amps per I/O point and 4 Amps per common, therefore the D3-08TRS-1 relay outputs are derated to 2 Amps per point and 4 Amps per common when used with the ZIPLink wiring system.

Power Budget

Managing your power resource

The I/O configuration depends on your choice of I/O modules, bases and I/O location. When determining the types and quantity of I/O modules you will be using, it's important to remember there is a limited amount of power available from the power supply.

The chart on the next page indicates the power supplied and used by each DL305

device. The adjacent chart shows an example of how to calculate the power used by your particular system. These two charts should make it easy for you to determine if the devices you have chosen fit within the power budget of your system configuration.

If the I/O you have chosen exceeds the maximum power available from the power

supply, you can resolve the problem by shifting some of the modules to an expansion base.

WARNING: IT IS EXTREMELY IMPORTANT TO CALCULATE THE POWER BUDGET CORRECTLY. IF YOU EXCEED THE POWER BUDGET, THE SYSTEM MAY OPERATE IN AN UNPREDICTABLE MANNER, WHICH MAY RESULT IN A RISK OF PERSONAL INJURY OR EQUIPMENT DAMAGE.

Example: How to calculate your power usage

The following example shows how to calculate the power budget for the DL305 system. The examples are constructed around a single 5-slot base using the devices shown. It is recommended you construct a similar table for each base in your DL305 system.

- Using a chart similar to the one below, fill in column 2.
- Using the tables on the opposite page, enter the current supplied and used by each device (columns 3, 4, and 5). Devices which fall into the "Other" category (Row D) are devices such as the Handheld Programmer or a Data Communication Unit, which also have power requirements, but do not directly plug into the base.
- Add the current used by the system devices (columns 3, 4, and 5), starting with Slot 1, then put the total in the row labeled "Maximum Current Required" (Row E).
- Subtract the row labeled "Maximum Current Required" (Row E), from the row labeled "Current Supplied" (Row B). Place the difference in the row labeled "Remaining Current" (Row F).
- If "Maximum Current Required" is greater than "Current Supplied" in columns 3, 4 or 5, the power budget will be exceeded. It will be unsafe to use this configuration and you will need to restructure your I/O configuration.

Use ZIPLinks to reduce power requirements

If your application requires a lot of relay outputs, consider using the ZIPLink AC or DC relay output modules. These modules can switch high current (10A) loads without putting a load on your base power budget. Refer to the Wiring Solutions section in this catalog for more information.

This logo is placed next to I/O modules that are supported by the ZipLink connection systems. See the I/O module specifications at the end of this section.



Example of System Power Requirements Calculation

A	Column 1	Column 2	Column 3	Column 4	Column 5
	Base # 0	Device Type	5 VDC (mA)	9VDC (mA)	24V(mA)
B	Current Supplied				
	5-slot Base	D3-05BDC	1400	800	500
C	Current Required				
	CPU Slot	D3-350	500	0	0
	Slot 0	D3-16NE3	0	130	0
	Slot 1	D3-16NE3	0	130	0
	Slot 2	F3-08TRS-1	0	296	0
	Slot 3	F3-04DAS	0	183	0
D	Other				
	Handheld prog D2-HPP		200	0	0
E	Maximum Current Required		700	739	0
F	Remaining Current		700	61	500

DL305 Power Requirements

This section shows the amount of power supplied by the base power supplies and the amount of power used by each DL305 device. **Note** the base power supplies provide three internal voltages (5V, 9V, 24V). The chart shows how much power from each of these power sources is required for each DL305 device. Use this information when calculating the power budget for your system.

In addition to the three internal power sources, the DL305 bases provide an external power connection. There is 24 VDC available from the 24 VDC output terminals on the bases (except D3-05BDC and D3-10BDC).

The 24 VDC can be used to power external devices or DL305 modules that require external 24 VDC. The power used from this external 24 VDC output reduces the internal system 24 VDC that is available to the modules by an equal amount. When using the 24 VDC output at the base terminal, do not exceed 100 mA current draw.

Power Consumed				
Device	5V (mA)	9V (mA)	24V (mA)	Ext req.
CPUs				
D3-350	500	0	0	0
DC Input Modules				
F3-16ND3F	0	148	68	0
AC/DC Input Modules				
D3-16NE3	0	130	0	0

Power Supplied				
Device	5V (mA)	9V (mA)	24V (mA)	24V (mA)
D3-05BDC	900	2000	500	None
D3-10BDC	900	2000	500	None
Power Consumed				
Device	5V (mA)	9V (mA)	24V (mA)	External required
Relay Output Modules				
F3-08TRS-1	0	296	0	0
F3-08TRS-2	0	296	0	0
Programming				
D2-HPP	200	0	0	0
Specialty CPUs				
F3-0MUX-2	262	0	150	0
Operator Interface				
C-more Micro-Graphic	210	0	0	0



Wiring Solutions



Wiring Solutions using the ZIPLink Wiring System

ZIPLinks eliminate the normally tedious process of wiring between devices by utilizing prewired cables and DIN rail mount connector modules. It's as simple as plugging in a cable connector at either end or terminating wires at only one end. Prewired cables keep installation clean and efficient, using half the space at a fraction of the cost of standard terminal blocks.

There are several wiring solutions available when using the ZIPLink System ranging from PLC I/O-to-ZIPLink Connector Modules that are ready for field termination, options for connecting to third party devices, GS, DuraPulse and SureServo Drives, and specialty relay, transorb and communications modules. Pre-printed I/O specific, adhesive label strips for quick marking of ZIPLink modules are provided with ZIPLink cables. See the following solutions to help determine the best ZIPLink system for your application.

Solution 1: DirectLOGIC I/O Modules to ZIPLink Connector Modules

When looking for quick and easy I/O-to-field termination, a ZIPLink connector module used in conjunction with a prewired ZIPLink cable, consisting of an I/O terminal block at one end and a multi-pin connector at the other end, is the best solution.

Using the PLC I/O Modules to ZIPLink Connector Modules selector tables located in this section,

1. Locate your I/O module/PLC.
2. Select a ZIPLink Module.
3. Select a corresponding ZIPLink Cable.



Solution 2: DirectLOGIC I/O Modules to 3rd Party Devices

When wanting to connect I/O to another device within close proximity of the I/O modules, no extra terminal blocks are necessary when using the ZIPLink Pigtail Cables. ZIPLink Pigtail Cables are prewired to an I/O terminal block with color-coded pigtail with soldered-tip wires on the other end.

Using the I/O Modules to 3rd Party Devices selector tables located in this section,

1. Locate your PLC I/O module.
2. Select a ZIPLink Pigtail Cable that is compatible with your 3rd party device.



Solution 3: GS Series and DuraPulse Drives Communication Cables

Need to communicate via Modbus RTU to a drive or a network of drives?

ZIPLink cables are available in a wide range of configurations for connecting to PLCs and SureServo, SureStep, Stellar Soft Starter and AC drives. Add a ZIPLink communications module to quickly and easily set up a multi-device network.

Using the Drives Communication selector tables located in this section,

1. Locate your Drive and type of communications.
2. Select a ZIPLink cable and other associated hardware.





Wiring Solutions



Solution 4: Serial Communications Cables

ZIPLink offers communications cables for use with DirectLOGIC, CLICK, and Productivity3000 CPUs, that can also be used with other communications devices. Connections include a 6-pin RJ12 or 9-pin, 15-pin and 25-pin D-sub connectors which can be used in conjunction with the RJ12 or D-Sub Feedthrough modules.

Using the Serial Communications Cables selector table located in this section,

1. Locate your connector type
2. Select a cable.



Solution 5: Specialty ZIPLink Modules

For additional application solutions, ZIPLink modules are available in a variety of configurations including stand-alone relays, 24 VDC and 120VAC transorb modules, D-sub and RJ12 feedthrough modules, communication port adapter and distribution modules, and SureServo 50-pin I/O interface connection.

Using the ZIPLink Specialty Modules selector table located in this section,

1. Locate the type of application.
2. Select a ZIPLink module.



Solution 6: ZIPLink Connector Modules to 3rd Party Devices

If you need a way to connect your device to terminal blocks without all that wiring time, then our pigtail cables with color-coded soldered-tip wires are a good solution. Used in conjunction with any compatible ZIPLink Connector Modules, a pigtail cable keeps wiring clean and easy and reduces troubleshooting time.

Using the Universal Connector Modules and Pigtail Cables table located in this section,

1. Select module type.
2. Select the number of pins.
3. Select cable.





PLC I/O Modules to ZIPLink Connector Modules - DL305

DL305 PLC Input Module ZIPLink Selector				
PLC		ZIPLink		
Input Module	# of Terms	Component	Module Part No.	Cable Part No.
F3-16ND3F	18	See Note 1		

DL305 PLC Output Module ZIPLink Selector				
PLC		ZIPLink		
Output Module	# of Terms	Component	Module Part No.	Cable Part No.
F3-08TRS-1	18	See Note 2		
F3-08TRS-2	18			



Note: See the Compatibility Matrix tables under the ZIPLink Connector Modules catalog section.

*1*These I/O modules have non-removable terminal blocks which can be terminated using the [ZL-CBL24-1P](#) or 2P pigtail cable and the [ZL-RTB20](#) module of the ZIPLink wiring system.

2 Module is not supported by the ZIPLink wiring system



DL305 System with ZIPLink Module and ZIPLink Cable



[ZL-CBL24-1P](#)