

Relay Output Modules

D2-04TRS Relay Output \$133.00	
Outputs per Module	4
Outputs Points Consumed	8 (only 1st 4pts. are used)
Commons per Module	4 (isolated)
Output Type	Relay, form A (SPST)
Operating Voltage	5-30 VDC / 5-240 VAC
Peak Voltage	30 VDC, 264 VAC
ON Voltage Drop	0.72 VDC maximum
AC Frequency	47 to 63 Hz
Minimum Load Current	10 mA
Max Load Current (resistive)	4A / point; 8A / module (resistive)
Max Leakage Current	0.1 mA @ 264 VAC
Max Inrush Current	5A for < 10 ms
Base Power Required 5VDC	250 mA
OFF to ON Response	10 ms
ON to OFF Response	10 ms
Terminal Type (included)	Removable; D2-8IOCON
Status Indicator	Logic side
Weight	2.8 oz. (80g)
Fuses	1 per point 6.3A slow blow, replaceable Order D2-FUSE-3 (5 per pack)

Typical Relay Life (Operations)				
Type of Load	Voltage & Load Current			
	1A	2A	3A	4A
24 VDC Resistive	500K	200K	100K	50K
24 VDC Solenoid	100K	40K	-	-
110 VAC Resistive	500K	250K	150K	100K
110 VAC Solenoid	200K	100K	50K	-
220 VAC Resistive	350K	150K	100K	50K
220 VAC Solenoid	100K	50K	-	-

At 24 VDC, solenoid (inductive) loads over 2A cannot be used.
 At 100 VAC, solenoid (inductive) loads over 3A cannot be used.
 At 220 VAC, solenoid (inductive) loads over 2A cannot be used.



See Wiring Solutions for part numbers of ZIP Link cables and connection modules compatible with this I/O module.

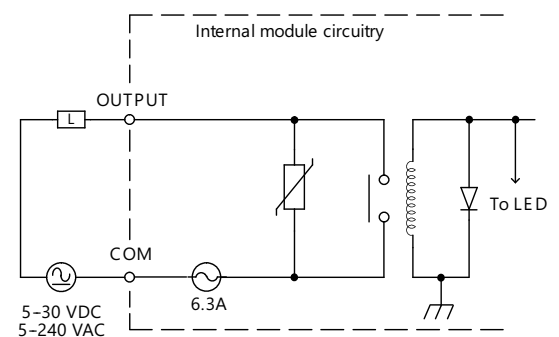
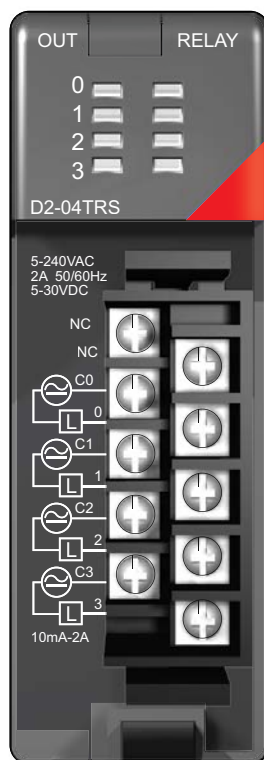
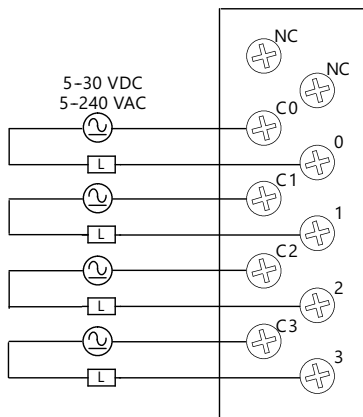
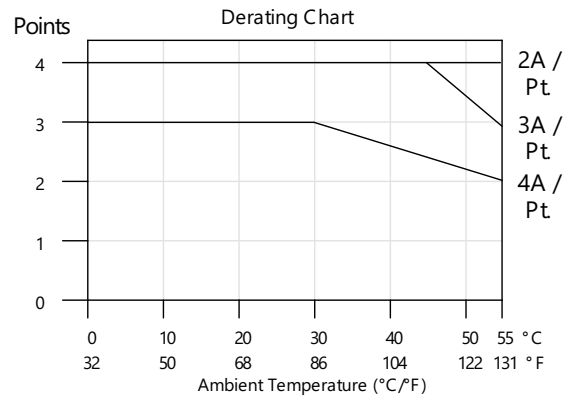

Relay Output Modules

D2-08TR Relay Output \$111.00	
Outputs per Module	8
Outputs Points Consumed	8
Commons per Module	1 (2 I/O terminals)
Output Type	Relay, form A (SPST)
Operating Voltage	5-30 VDC; 5-240 VAC
Peak Voltage	30 VDC, 264 VAC
ON Voltage Drop	N/A
AC Frequency	47 to 60 Hz
Minimum Load Current	5 mA @ 5 VDC
Max Load Current (resistive)	1A / point; 4A / common
Max Leakage Current	0.1 mA @ 265 VAC
Max Inrush Current	Output: 3A for 10 ms Common: 10A for 10 ms
Base Power Required 5VDC	250 mA
OFF to ON Response	12 ms
ON to OFF Response	10 ms
Terminal Type (included)	Removable; D2-8I/OCON
Status Indicator	Logic side
Weight	3.9 oz. (110g)
Fuses	One 6.3 A slow blow, replaceable Order D2-FUSE-3 (5 per pack)

Typical Relay Life (Operations)		
Voltage/Load	Current	Closures
24 VDC Resistive	1A	500K
24 VDC Solenoid	1A	100K
110 VAC Resistive	1A	500K
110 VAC Solenoid	1A	200K
220 VAC Resistive	1A	350K
220 VAC Solenoid	1A	100K

See Wiring Solutions for part numbers of ZIPLink cables and connection modules compatible with this I/O module.



Note: When used with the ZIPLink wiring system, relay outputs are derated not to exceed 2 Amps per point max.

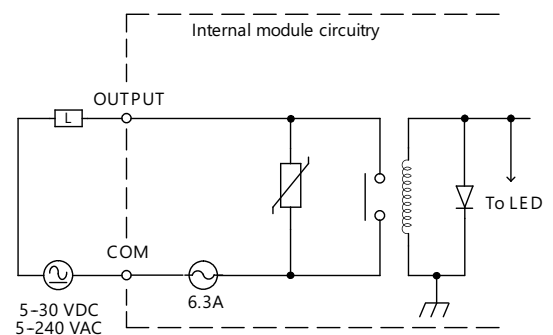
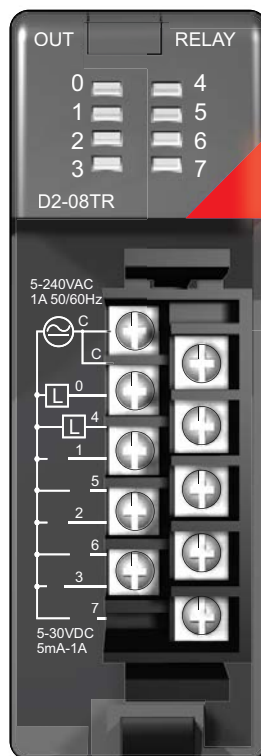
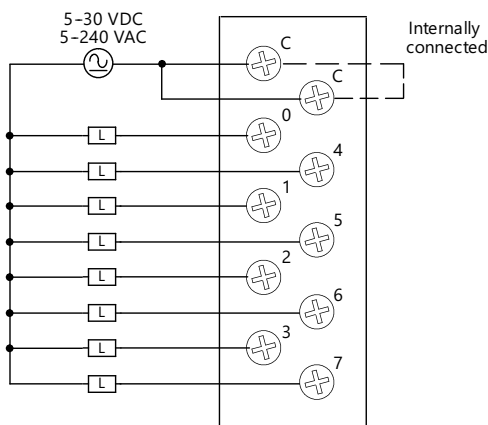
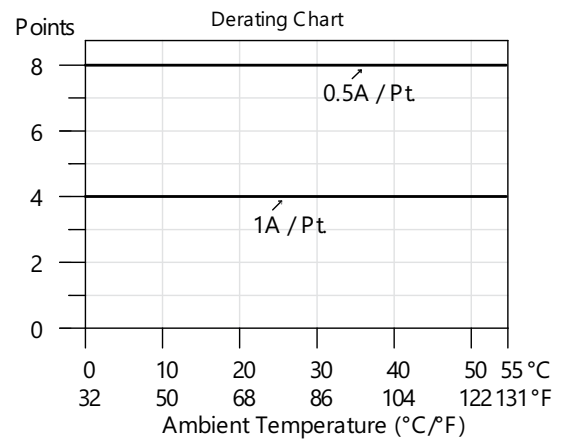

Relay Output Modules

F2-08TRS Relay Output \$204.00	
Outputs per Module	8
Outputs Points Consumed	8
Commons per Module	8 (isolated)
Output Type	3, Form C (SPDT) 5, Form A (SPST normally open)
Operating Voltage	7A @ 12-28 VDC, 12-250 VAC 0.5A @ 120 VDC
Peak Voltage	150 VDC, 265 VAC
ON Voltage Drop	N/A
AC Frequency	47 to 63 Hz
Minimum Load Current	10 mA @ 12 VDC
Max Load Current (resistive)	7A / point ³ (subject to derating)
Max Leakage Current	N/A
Max Inrush Current	12A
Base Power Required 5VDC	670 mA
OFF to ON Response	15 ms (typical)
ON to OFF Response	5 ms (typical)
Terminal Type (included)	Removable; D2-8IOCON
Status Indicator	Logic side
Weight	5.5 oz. (156g)
Fuses	None

Typical Relay Life (Operations) at Room Temperature			
Type of Load	Voltage & Load Current		
	50 mA	5A	7A
24 VDC Resistive	10M	600K	300K
24 VDC Solenoid	-	150K	75K
110 VAC Resistive	-	600K	300K
110 VAC Solenoid	-	500K	200K
220 VAC Resistive	-	300K	150K
220 VAC Solenoid	-	250K	100K

1) Contact life may be extended beyond those values shown with the use of arc suppression techniques described in the DL205 User Manual. Since these modules have no leakage current, they do not have built-in snubber. For example, if you place a diode across a 24 VDC inductive load, you can significantly increase the life of the relay.

2) At 120 VDC 0.5A resistive load, contact life cycle is 200K cycles.

3) Normally closed contacts have 1/2 the current handling capability of the normally open contacts.



See Wiring Solutions for part numbers of **ZIPLink** cables and connection modules compatible with this I/O module.

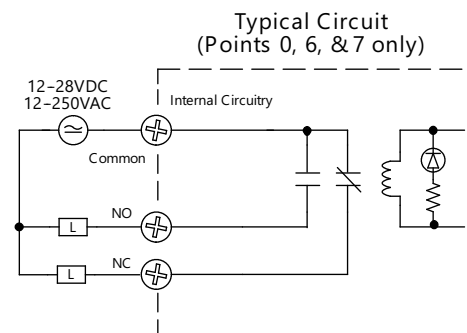
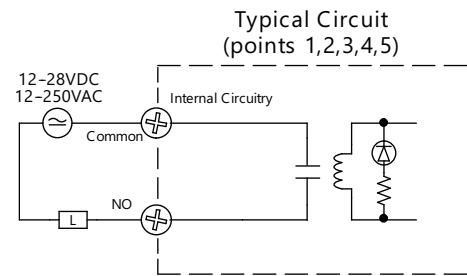
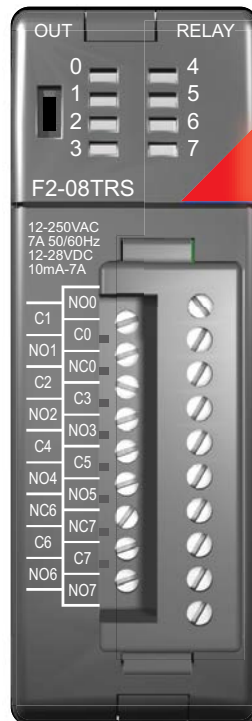
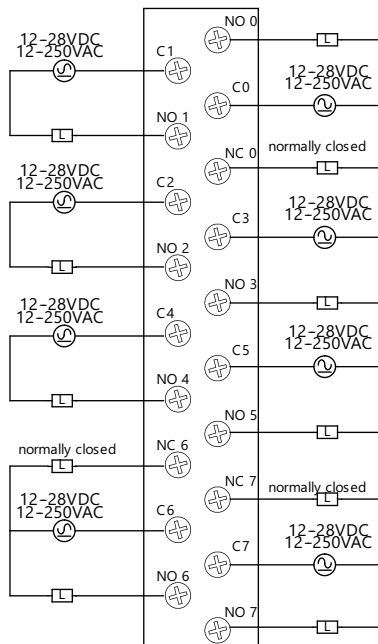
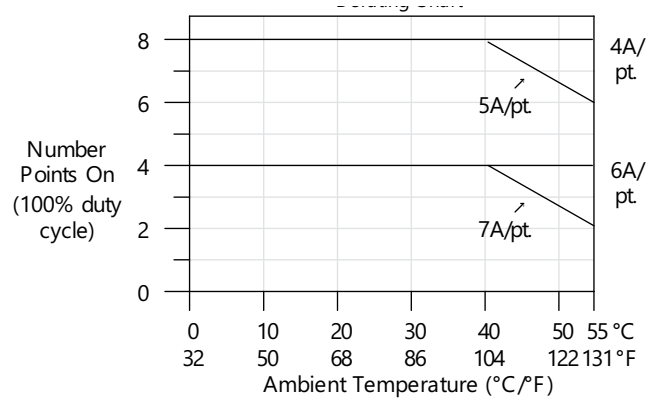

Relay Output Modules

F2-08TR Relay Output \$152.00	
Outputs per Module	8
Outputs Points Consumed	8
Commons per Module	2 (isolated), 4-pts. per common
Output Type	8, Form A (SPST normally open)
Operating Voltage	7A @ 12-28 VDC, 12-250 VAC; 0.5A @ 120 VDC
Peak Voltage	150 VDC, 265 VAC
ON Voltage Drop	N/A
AC Frequency	47 to 63 Hz
Minimum Load Current	10 mA @ 12 VDC
Max Load Current (resistive)	10A / point ³ (subject to derating) Max of 10A/common
Max Leakage Current	N/A
Max Inrush Current	12A
Base Power Required 5VDC	670 mA
OFF to ON Response	15 ms (typical)
ON to OFF Response	5 ms (typical)
Terminal Type (included)	Removable; D2-8IOCON
Status Indicator	Logic side
Weight	5.5 oz. (156g)
Fuses	None

Typical Relay Life (Operations) at Room Temperature			
Type of Load	Voltage & Load Current		
	50 mA	5A	7A
24 VDC Resistive	10M	600K	300K
24 VDC Solenoid	-	150K	75K
110 VAC Resistive	-	600K	300K
110 VAC Solenoid	-	500K	200K
220 VAC Resistive	-	300K	150K
220 VAC Solenoid	-	250K	100K

1) Contact life may be extended beyond those values shown with the use of arc suppression techniques described in the DL205 User Manual. Since these modules have no leakage current, they do not have built-in snubber. For example, if you place a diode across a 24 VDC inductive load, you can significantly increase the life of the relay.

2) At 120 VDC 0.5A resistive load, contact life cycle is 200K cycles.

3) Normally closed contacts have 1/2 the current handling capability of the normally open contacts.

See Wiring Solutions for part numbers of **ZIPLink** cables and connection modules compatible with this I/O module.



Number Points On (100% duty cycle)

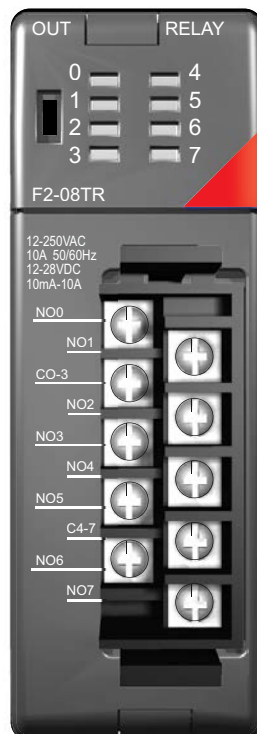
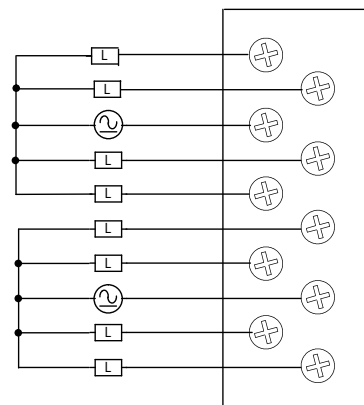
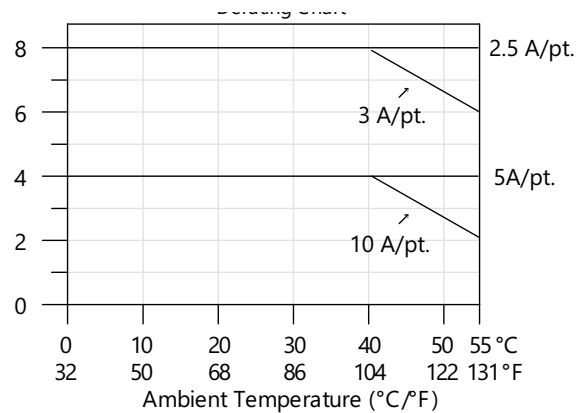

Typical Circuit

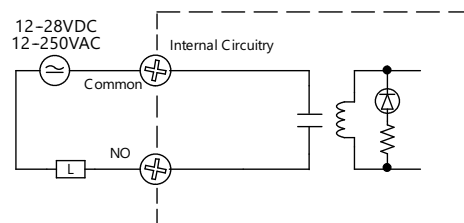

Relay Output Modules

D2-12TR Relay Output \$184.00	
Outputs per Module	12
Outputs Points Consumed	16 (four unused, see chart below)
Commons per Module	2 (6-pts. per common)
Output Type	Relay, form A (SPST)
Operating Voltage	5-30 VDC; 5-240 VAC
Peak Voltage	30 VDC; 264 VAC
ON Voltage Drop	N/A
AC Frequency	47 to 60 Hz
Minimum Load Current	5 mA @ 5VDC
Max Load Current (resistive)	1.5A / point; Max of 3A / common
Max Leakage Current	0.1 mA @ 265 VAC
Max Inrush Current	Output: 3A for 10 ms Common: 10A for 10 ms
Base Power Required 5VDC	450 mA
OFF to ON Response	10 ms
ON to OFF Response	10 ms
Terminal Type (included)	Removable; D2-8IOCON
Status Indicator	Logic side
Weight	4.6 oz. (130g)
Fuses	(2) 4A slow blow, replaceable Order D2-FUSE-4 (5 per pack)

See Wiring Solutions for part numbers of **ZIPlink** cables and connection modules compatible with this I/O module.



Typical Relay Life (Operations)		
Voltage/Load	Current	Closures
24 VDC Resistive	1A	500K
24 VDC Solenoid	1A	100K
110 VAC Resistive	1A	500K
110 VAC Solenoid	1A	200K
220 VAC Resistive	1A	350K
220 VAC Solenoid	1A	100K

Addresses Used			
Points	Used?	Points	Used?
Yn+0	Yes	Yn+10	Yes
Yn+1	Yes	Yn+11	Yes
Yn+2	Yes	Yn+12	Yes
Yn+3	Yes	Yn+13	Yes
Yn+4	Yes	Yn+14	Yes
Yn+5	Yes	Yn+15	Yes
Yn+6	No	Yn+16	No
Yn+7	No	Yn+17	No

n is the starting address

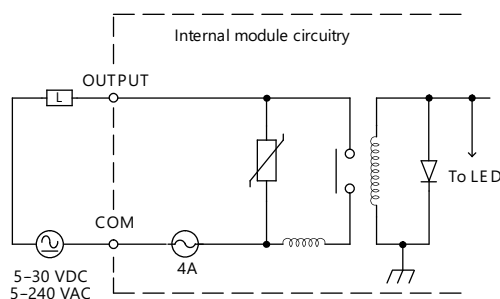
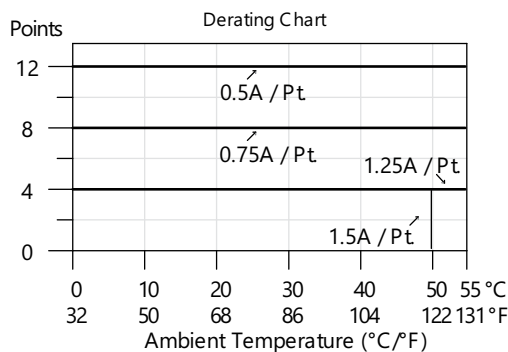
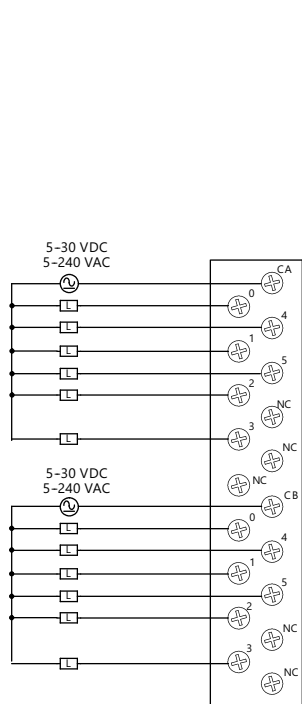

DC Input/Relay Output Module

D2-08CDR 4-pt. DC In / 4pt. Relay Out \$98.00	
General Specifications	
Base Power Required 5VDC	200 mA
Terminal Type (included)	Removable; D2-8IOCON
Status Indicator	Logic side
Weight	3.5 oz. (100g)
Input Specifications	
Inputs per Module	4 (sink/source)
Input Points Consumed	8 (only first 4-pts. are used)
Commons per Module	1
Input Voltage Range	20–28 VDC
Peak Voltage	30 VDC
ON Voltage Level	19 VDC minimum
OFF Voltage Level	7 VDC maximum
AC Frequency	N/A
Input Impedance	4.7 kΩ
Input Current	5 mA @ 24 VDC
Maximum Current	8 mA @ 30 VDC
Minimum ON Current	4.5 mA
Maximum OFF Current	1.5 mA
OFF to ON Response	1 to 10 ms
ON to OFF Response	1 to 10 ms
Fuses (input circuits)	None

Output Specifications	
Outputs per Module	4
Outputs Points Consumed	8 (only first 4-pts. are used)
Commons per Module	1
Output Type	Relay, form A (SPST)
Operating Voltage	5–30 VDC; 5–240 VAC
Peak Voltage	30 VDC; 264 VAC
ON Voltage Drop	N/A
AC Frequency	47 to 63 Hz
Minimum Load Current	5 mA @ 5VDC
Max Load Current (resistive)	1A / point ; 4A / module
Max Leakage Current	0.1 mA @ 264 VAC
Max Inrush Current	3A for < 100 ms 10A for < 10 ms (common)
OFF to ON Response	12 ms
ON to OFF Response	10 ms
Fuses (output circuits)	1 (6.3A slow blow, replaceable); Order D2-FUSE-3 (5 per pack)

See Wiring Solutions for part numbers of **ZIPLink** cables and connection modules compatible with this I/O module.



Typical Relay Life (Operations)		
Voltage/Load	Current	Closures
24 VDC Resistive	1A	500K
24 VDC Solenoid	1A	100K
110 VAC Resistive	1A	500K
110 VAC Solenoid	1A	200K
220 VAC Resistive	1A	350K
220 VAC Solenoid	1A	100K

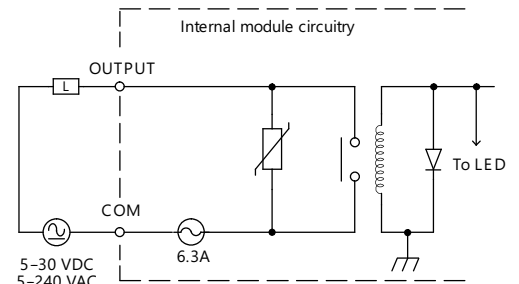
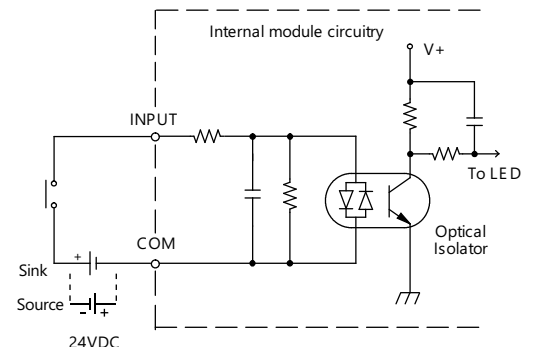
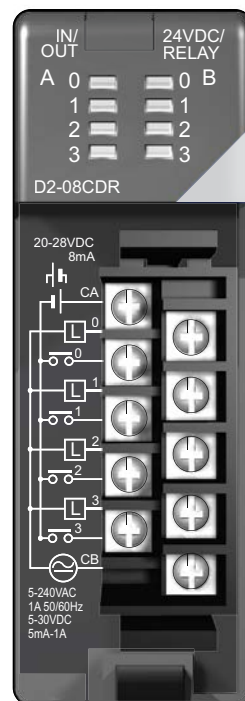
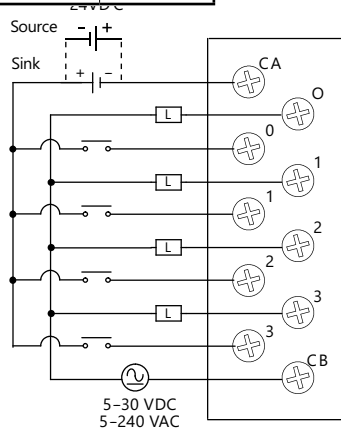
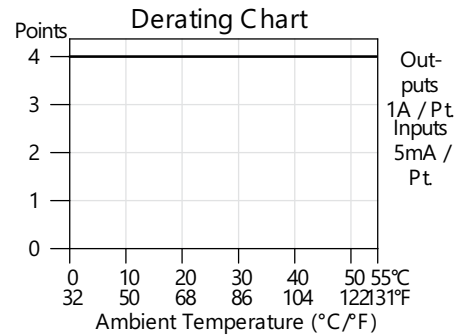

For "Sinking and Sourcing Concepts", see the Appendix section in this catalog.

ZIPLINK™ Wiring Solutions

AUTOMATIONDIRECT

Wiring Solutions using the ZIPLink Wiring System

ZIPLinks eliminate the normally tedious process of wiring between devices by utilizing prewired cables and DIN rail mount connector modules. It's as simple as plugging in a cable connector at either end or terminating wires at only one end.

Prewired cables keep

installation clean and efficient, using half the space at a fraction of the cost of standard terminal blocks. There are several wiring

solutions available when using the ZIPLink System ranging from PLC I/O-to-ZIPLink Connector Modules that are ready for field

termination, options for connecting to third party devices, GS, DuraPulse and SureServo Drives, as well as special relay, transorb and communications modules. Pre-printed I/O-specific adhesive label strips for quick marking of ZIPLink modules are provided with ZIPLink cables. See the following solutions to help determine the best ZIPLink system for your application.

Solution 1: Do-more, DirectLOGIC, CLICK and Productivity Series I/O Modules to ZIPLink Connector Modules

When looking for quick and easy I/O-to-field termination, a ZIPLink connector module used in conjunction with a prewired ZIPLink cable, consisting of an I/O terminal block at one end and a multi-pin connector at the other end, is the best solution.



Using the PLC I/O Modules to ZIPLink Connector Modules selector tables located in this section,

1. Locate your I/O module/PLC
2. Select a ZIPLink Module
3. Select a corresponding ZIPLink Cable.

Solution 2: Do-more, DirectLOGIC, CLICK and Productivity Series I/O Modules to 3rd Party Devices

When wanting to connect I/O to another device within proximity of the I/O modules, no extra terminal blocks are necessary when using the ZIPLink Pigtail Cables. ZIPLink Pigtail Cables are prewired to an I/O terminal block with color-coded pigtail with soldered-tip wires on the other end.



Using the I/O Modules to 3rd Party Devices selector tables located in this section,

1. Locate your PLC I/O module
2. Select a ZIPLink Pigtail Cable that is compatible with your 3rd party device.

Solution 3: GS Series and DuraPulse Drives Communication Cables

Need to communicate via Modbus RTU to a drive or a network of drives?

ZIPLink cables are available in a wide range of configurations for connecting to PLCs and SureServo, SureStep, Stellar Soft Starter and AC drives. Add a ZIPLink communications module to quickly and easily set up a multi-device network.

Using the Drives Communication selector tables located in this section,

1. Locate your Drive and type of communications
2. Select a ZIPLink cable and other associated hardware.



ZIPLINK™ Wiring Solutions

AUTOMATIONDIRECT

Solution 4: Serial Communications Cables

ZIPLink offers communications cables for use with **DirectLOGIC**, CLICK, and Productivity CPUs, that can also be used with other communications devices. Connections include a 6-pin RJ12 or 9-pin, 15-pin and 25-pin D-sub connectors which can be used in conjunction with the RJ12 or D-Sub feedthrough modules.

Using the Serial Communications Cables selector table located in this section,

1. Locate your connector type
2. Select a cable.



Solution 5: Specialty ZIPLink Modules

For additional application solutions, **ZIPLink** modules are available in a variety of configurations including stand-alone relays, 24 VDC and 120 VAC transorb modules, D-sub, RJ12 and RJ45 feedthrough modules, communication port adapter and distribution modules, and SureServo 50-pin I/O interface connection.

Using the **ZIPLink** Specialty Modules selector table located in this section,

1. Locate the type of application
2. Select a **ZIPLink** module.



Solution 6: ZIPLink Connector Modules to 3rd Party Devices

If you need a way to connect your device to terminal blocks without all that wiring time, then our pigtail cables with color-coded soldered-tip wires are a good solution. Used in conjunction with any compatible **ZIPLink** Connector Modules, a pigtail cable keeps wiring clean and easy and reduces troubleshooting time.

Using the Universal Connector Modules and Pigtail Cables table located in this section,

1. Select module type
2. Select the number of pins
3. Select cable.





PLC I/O Modules to ZIPLink Connector Modules – Do-more!/DL205

Do-more / DL205 PLC Input Module ZIPLink Selector				
PLC	ZIPLink			
Input Module	# of Terms	Component	Module Part No.	Cable Part No. †
D2-08ND3	10	Feedthrough	ZL-RTB20 (-1)	ZL-D2-CBL10 *
D2-16ND3-2	19	Feedthrough		ZL-D2-CBL19
		Sensor	ZL-LTB16-24-1	ZL-D2-CBL19-1 ZL-D2-CBL19-2
D2-32ND3 1	40	Feedthrough	ZL-RTB40 (-1)	180 deg conn: ZL-D24-CBL40
		Sensor	ZL-LTB32-24-1	ZL-D24-CBL40-1 ZL-D24-CBL40-2
D2-32ND3-2 1	40	Feedthrough	ZL-RTB40(-1)	45 deg conn: ZL-D24-CBL40-X ZL-D24-CBL40-1X ZL-D24-CBL40-2X
		Sensor	ZL-LTB32-24-1	
D2-08NA-1	10	Feedthrough	ZL-RTB20 (-1)	ZL-D2-CBL10
D2-08NA-2	10			ZL-D2-CBL10-1
D2-16NA	19			ZL-D2-CBL10-2
				ZL-D2-CBL19 *

† X in the part number represents a 45° angle.

Do-more/DL205 PLC Combo In/Out Module ZIPLink Selector				
PLC	ZIPLink			
Combo Module	# of Terms	Component	Module Part No.	Cable Part No.
D2-08CDR	10	Feedthrough	ZL-RTB20 (-1)	ZL-D2-CBL10 *

Do-more/DL205 PLC Analog Module ZIPLink Selector							
PLC	ZIPLink						
Analog Module	# of Terms	Component	Module	Cable			
F2-04AD-1	10	Feedthrough	ZL-RTB20 (-1)	ZL-D2-CBL10 ZL-D2-CBL10-1 ZL-D2-CBL10-2			
F2-08AD-1							
F2-04AD-2							
F2-08AD-2							
F2-02DA-1							
F2-02DAS-1							
F2-08DA-1				ZL-D2-CBL19 ZL-D2-CBL19-1 ZL-D2-CBL19-2			
F2-02DA-2							
F2-02DAS-2							
F2-08DA-2							
F2-4AD2DA				19			ZL-D2-CBL10 ZL-D2-CBL10-1 ZL-D2-CBL10-2
F2-8AD4DA-1							
F2-8AD4DA-2							
F2-04RTD				Matched Only	These modules are not supported by the ZIPLink wiring system		
F2-04THM							

Do-more/ DL205 PLC Output Module ZIPLink Selector				
PLC	ZIPLink			
Output Module	# of Terms	Component	Module Part No.	Cable Part No. †
D2-04TD1 2	10	Feedthrough	ZL-RTB20 (-1)	ZL-D2-CBL10
D2-08TD1				ZL-D2-CBL10-1
D2-08TD2				ZL-D2-CBL10-2
D2-16TD1-2	19	Feedthrough	ZL-RTB20 (-1)	ZL-D2-CBL19 ZL-D2-CBL19-1 ZL-D2-CBL19-2
		Fuse		
Feedthrough		ZL-RTB20 (-1)		
Fuse		ZL-RFU20 4		
D2-16TD2-2		Relay	ZL-RRL16-24-2 ZL-RRL16W-24-2 ZL-RRL16F-24-2 ZL-RRL16HDF-24-2	
		Feedthrough	ZL-RTB20 (-1)	
F2-16TD1P				
F2-16TD2P				
D2-32TD1 1	40	Feedthrough	ZL-RTB40 (-1)	180 deg conn: ZL-D24-CBL40 ZL-D24-CBL40-1 ZL-D24-CBL40-2
		Fuse	ZL-RFU40 4	
		Feedthrough	ZL-RTB40 (-1)	
Fuse		ZL-RFU40 4		
D2-32TD2 1				45 deg conn: ZL-D24-CBL40-X ZL-D24-CBL40-1X ZL-D24-CBL40-2X
D2-08TA	10	Feedthrough	ZL-RTB20 (-1)	ZL-D2-CBL10 ZL-D2-CBL10-1 ZL-D2-CBL10-2
F2-08TA				
D2-12TA	19	Feedthrough	ZL-RFU20 4	ZL-D2-CBL19 ZL-D2-CBL19-1 ZL-D2-CBL19-2
		Fuse		
D2-04TRS 2	10	Feedthrough	ZL-RTB20 (-1)	ZL-D2-CBL10 ZL-D2-CBL10-1 ZL-D2-CBL10-2
D2-08TR				
F2-08TRS 2				
F2-08TR 3	10			ZL-D2-CBL19 *
D2-12TR	19	Feedthrough	ZL-RFU20 4	ZL-D2-CBL19 ZL-D2-CBL19-1 ZL-D2-CBL19-2
		Fuse		

† X in the part number represents a 45° angle plug

* Select the cable length by replacing the * with: Blank = 0.5m, -1 = 1.0m, or -2 = 2.0m.

1 To make a custom cable for the 32-point modules, use: Solder-style 180° connector ZL-D24-CON or Solder-style 45° connector ZL-D24-CON-X

2 Caution: The D2-04TD1, D2-04TRS, and F2-08TRS outputs are derated not to exceed module specs 2A per point and 2A per common when used with the ZIPLink wiring system.

3 The F2-08TR outputs are derated not to exceed 2A per point and 4A per common when used with the ZIPLink wiring system.

4 Fuses (5 x 20mm) are not included. See Edison Electronic Fuse section for (5 x 20mm) fuse. S506 and GMA electronic circuit protection for fast-acting maximum protection. S506 and GMC electronic circuit protection for time-delay performance. Ideal for inductive circuits. To ensure proper operation, do not exceed the voltage and current rating of ZIPLink module. ZL-RFU20 = 2A per circuit; ZL-RFU40 = 400 mA per circuit.



Note: ZIPLink Connector Module specifications follow the Compatibility Matrix tables. ZIPLink Cables specifications are at the end of this ZIPLink section.



Dimensions and Installation

Understanding the installation requirements for your DL205 system will help ensure that the DL205 products operate within their environmental and electrical limits.

Plan for safety

This catalog should never be used as a replacement for the user manual. The user manual, D2-USER-M (downloadable online), contains important safety information that must be followed. The system installation should comply with all appropriate electrical codes and standards.

Environmental specifications

The Environmental Specifications table at the right lists specifications that apply globally to the DL205 system (CPUs, bases, and I/O modules). Be sure that the DL205 system is operated within these environmental specifications.

Base dimensions and mounting

Use the diagrams below to make sure the DL205 system can be installed in your application. To ensure proper airflow for cooling purposes, DL205 bases must be mounted horizontally. It is important to check these dimensions against the conditions required for your application. For example, it is recommended that approximately 3" of space is left in front PLC surface for ease of access and cable clearances. Also, check the installation guidelines for recommended cabinet clearances.

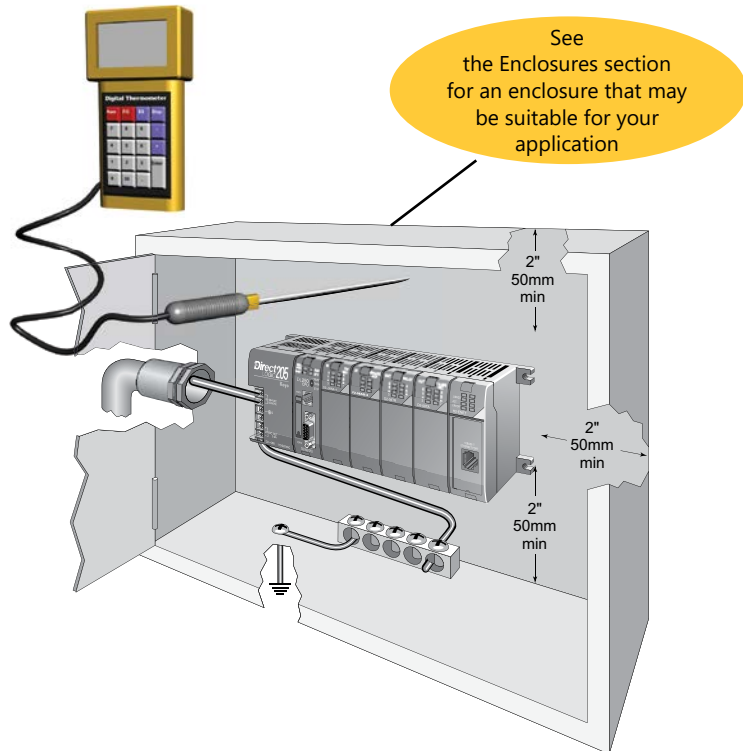

Environmental Specification	Rating
Storage Temperature	-4 to +158 °F (-20 to +70 °C)
Ambient Operating Temperature	32 to 131 °F (0 to 55 °C)
Ambient Humidity	30% to 95% relative humidity (non-condensing)
Vibration Resistance	MIL STD 810C, Method 514.2
Shock Resistance	MIL STD 810C, Method 516.2
Noise Immunity	NEMA (ICS3-304)
Atmosphere	No corrosive gases

Base	A	B	C	D
D2-03B-1, D2-03BDC1-1	6.77" 172mm	6.41" 163mm	5.8" 148mm	7.24" 184mm
D2-04B-1, D2-04BDC1-1	7.99" 203mm	7.63" 194mm	7.04" 179mm	8.46" 215mm
D2-06B-1, D2-06BDC1-1, D2-06BDC2-1	10.43" 265mm	10.07" 256mm	9.48" 241mm	10.90" 277mm
D2-09B-1, D2-09BDC1-1, D2-09BDC2-1	14.09" 358mm	13.74" 349mm	13.14" 334mm	14.56" 370mm

