

Analog Current Input Modules

F2-04AD-1 4-Channel 4-20mA Analog In \$403.00	
This module can be powered by either a 12 VDC or 24 VDC power supply, and is a direct replacement for F2-04AD-1L modules.	
Number of Channels	4, single ended (1 common)
Input Ranges	4 to 20 mA current
Resolution	12-bit (1 in 4096)
Active Low-pass Filtering	-3 dB at 120 Hz, 2 poles (-12 dB per octave)
Input Impedance	250Ω ±0.1%, 1/2W current input
Absolute Maximum Ratings	-40 to +40 mA, current input
Converter Type	Successive approximation
Conversion Time (PLC Update Rate)	4 channels per scan maximum (D2-262 CPU)
Linearity Error (End to End)	±1 count (0.025% of full scale) maximum
Input Stability	±1 count
Full Scale Calibration Error (offset error not included)	±12 counts max., @ 20 mA current input
Offset Calibration Error	±7 counts max., @ 4 mA current input
Step Response	4.9 ms to 95% of F.S. change

Maximum Inaccuracy	±.5% @ 77 °F (25 °C) ±.65% 32 to 140 °F (0 to 60 °C)
Accuracy vs. Temperature	±50 ppm / °C maximum full scale (including max. offset change)
Recommended Fuse	0.032A, Series 217 fast-acting, current inputs
Digital Input Points Required	16 (X) input points (12 binary data bits, 2 channel ID bits, 2 diagnostic bits)
Base Power Required 5 VDC	100 mA
External Power Supply	5 mA maximum, +10 to +30 VDC
Operating Temperature	32 to 140 °F (0 to 60 °C)
Storage Temperature	-4° to +158 °F (-20 to +70 °C)
Relative Humidity	5 to 95% (non-condensing)
Environmental Air	No corrosive gases permitted
Vibration	MIL STD 810C 514.2
Shock	MIL STD 810C 516.2
Noise Immunity	NEMA ICS3-304
Terminal Type (included)	Removable; D2-8IOCON

See Wiring Solutions for part numbers of ZIPLink cables and connection modules compatible with this I/O module.



Note 1: Shields should be grounded at the signal source

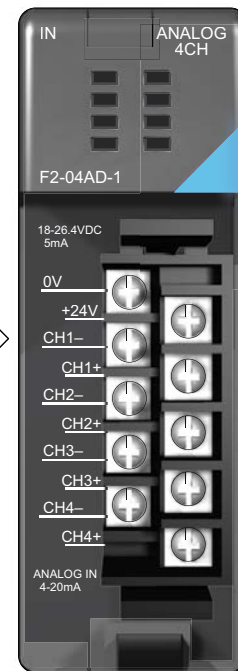
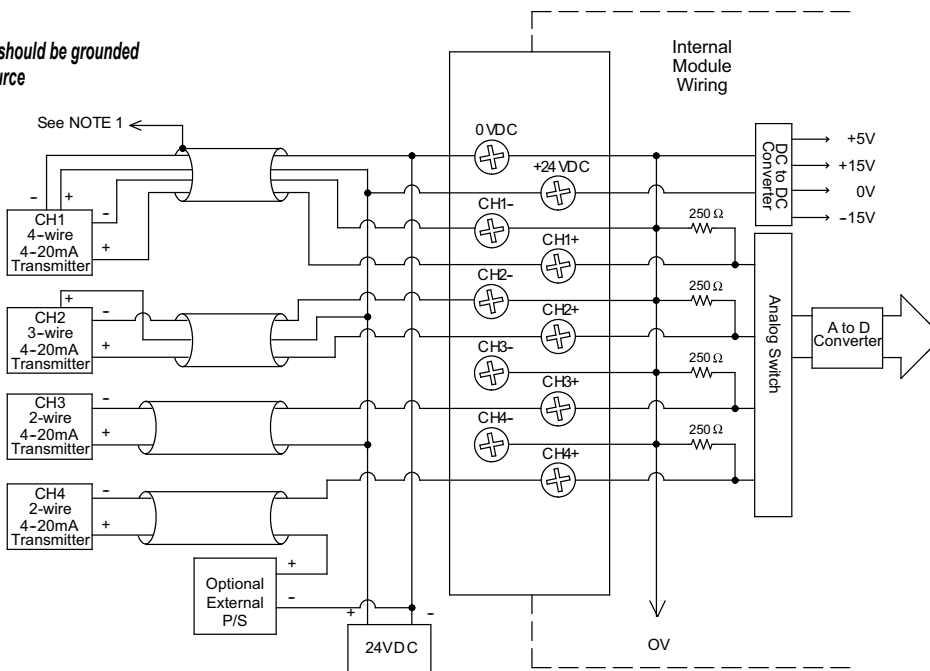

More than one external power supply can be used provided all the power supply commons are connected. A Series 217, 0.032 A, fast-acting fuse is recommended for 4-20 mA current loops. If the power supply common of an external power supply is not connected to 0 VDC on the module, then the output of the external transmitter must be isolated. To avoid "ground loop" errors, recommended 4-20 mA transmitter types are:

- 2 or 3 wire: Isolation between input signal and power supply.
- 4 wire: Isolation between input signal, power supply, and 4-20 mA output

Analog Current Input Modules

F2-08AD-1 8-Channel 4-20mA Analog In \$495.00	
Number of Channels	8, single ended (1 common)
Input Ranges	4 to 20 mA current
Resolution	12 bit (1 in 4096)
Low-pass Filtering	-3 dB at 200 Hz, (-6 dB per octave)
Input Impedance	250Ω ±0.1%, 1/2W current input
Absolute Maximum Ratings	-45 to +45 mA
Converter Type	Successive approximation
Conversion Time (PLC Update Rate)	8 channels per scan maximum (D2-250-1 and D2-262 CPUs)
Linearity Error (End to End)	±1 count (0.025% of full scale) maximum
Input Stability	±1 count
Full Scale Calibration Error (offset error not included)	±5 counts max., @ 20 mA current input
Offset Calibration Error	±2 counts max., @ 4 mA current input
Step Response	1ms to 95% of F.S. change

Maximum Inaccuracy	±.1% @ 77 °F (25 °C) ±.25% 32 to 140 °F (0 to 60 °C)
Accuracy vs. Temperature	±50 ppm / °C maximum full scale (including max. offset change of two counts)
Recommended Fuse	0.032A, Series 217 fast-acting, current inputs
Digital Input Points Required	16 (X) input points (12 binary data bits, 3 channel ID bits, 1 broken transmitter bit)
Base Power Required 5VDC	100 mA
External Power Supply	5 mA maximum, 10 to 30 VDC
Operating Temperature	32 to 140 °F (0 to 60 °C)
Storage Temperature	-4 to +158 °F (-20 to +70 °C)
Relative Humidity	5 to 95% (non-condensing)
Environmental Air	No corrosive gases permitted
Vibration	MIL STD 810C 514.2
Shock	MIL STD 810C 516.2
Noise Immunity	NEMA ICS3-304
Terminal Type (included)	Removable; D2-8IOCON

See Wiring Solutions for part numbers of **ZIPLink** cables and connection modules compatible with this I/O module.



Note 1: Shields should be grounded at the signal source.

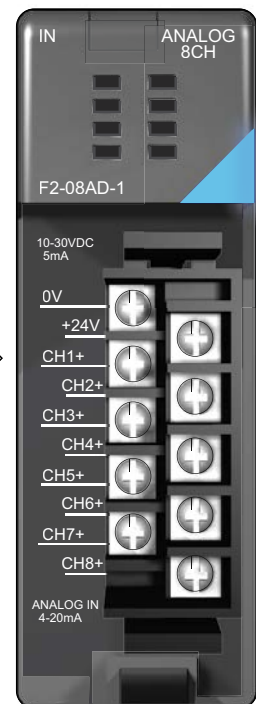
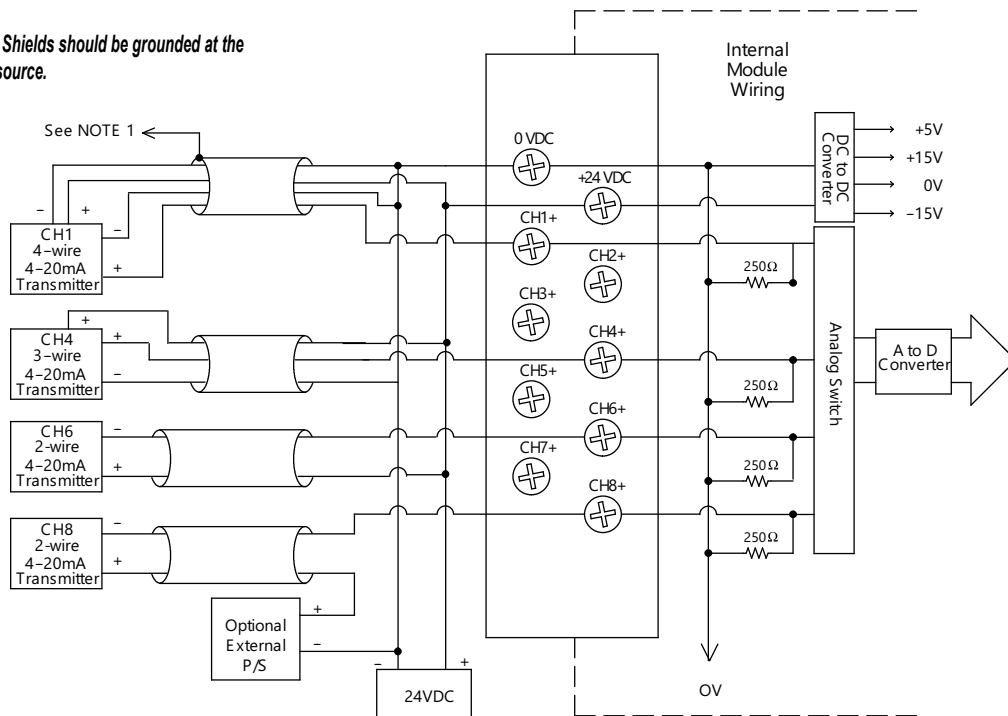

More than one external power supply can be used provided all the power supply commons are connected. A Series 217, 0.032 A, fast-acting fuse is recommended for 4-20 mA current loops. If the power supply common of an external power supply is not connected to 0 VDC on the module, then the output of the external transmitter must be isolated. To avoid "ground loop" errors, recommended 4-20 mA transmitter types are:

2 or 3 wire: Isolation between input signal and power supply.

4 wire: Isolation between input signal, power supply, and 4-20 mA output

Analog Voltage Input Modules

F2-04AD-2 4-Channel Voltage Analog In \$440.00	
This module can be powered by either a 12 VDC or 24 VDC power supply, and is a direct replacement for F2-04AD-2L modules.	
Number of Channels	4, single ended (1 common)
Input Ranges	0 to 5 V, 0 to 10 V, ±5V, ±10V
Resolution	12 bit (1 in 4096)
Active Low-pass Filtering	-3 dB at 80 Hz, 2 poles (-12 dB per octave)
Input Impedance	>20 MΩ
Absolute Maximum Ratings	-75 to +75 VDC
Converter Type	Successive approximation
Conversion Time (PLC Update Rate)	4 channels per scan maximum (D2-262 CPU)
Linearity Error (End to End)	±1 count (0.025% of full scale) maximum ±2 counts maximum (bi-polar)
Input Stability	±1 count
Full Scale Calibration Error (offset error not included)	±3 counts maximum
Offset Calibration Error	±1 count maximum (0V input)
Step Response	8.2 ms to 95% of F.S change

Maximum Inaccuracy	± 0.1% @ 77 °F (25 °C) ± 0.3% 32 to 140 °F (0 to 60 °C)
Accuracy vs Temperature	± 50 ppm / °C full scale calibration change (including maximum offset change)
Digital Input Points Required	16(x) input points (12 binary data bits, 2 channel ID bits)
Base Power Required 5VDC	110 mA
External Power Supply	5 mA maximum, +10 to +30 VDC
Operating Temperature	32 to 140 °F (0 to 60 °C)
Storage Temperature	-4 to +158 °F (-20 to 70 °C)
Relative Humidity	5% to 95% (non-condensing)
Environmental Air	No corrosive gases permitted
Vibration	MIL STD 810C 514.2
Shock	MIL STD 810C 516.2
Noise Immunity	NEMA ICS3-304
Terminal Type (included)	Removable; D2-8IOCON

See Wiring Solutions for part numbers of ZIPLink cables and connection modules compatible with this I/O module.



Note 1: Shields should be grounded at the signal source.

Note 2: Unused inputs should be jumpered together (i.e. CH4- to CH4+).

Note 3: More than one external power supply can be used provided the commons are connected together.

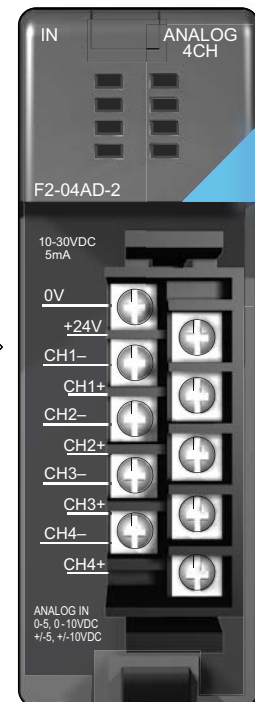
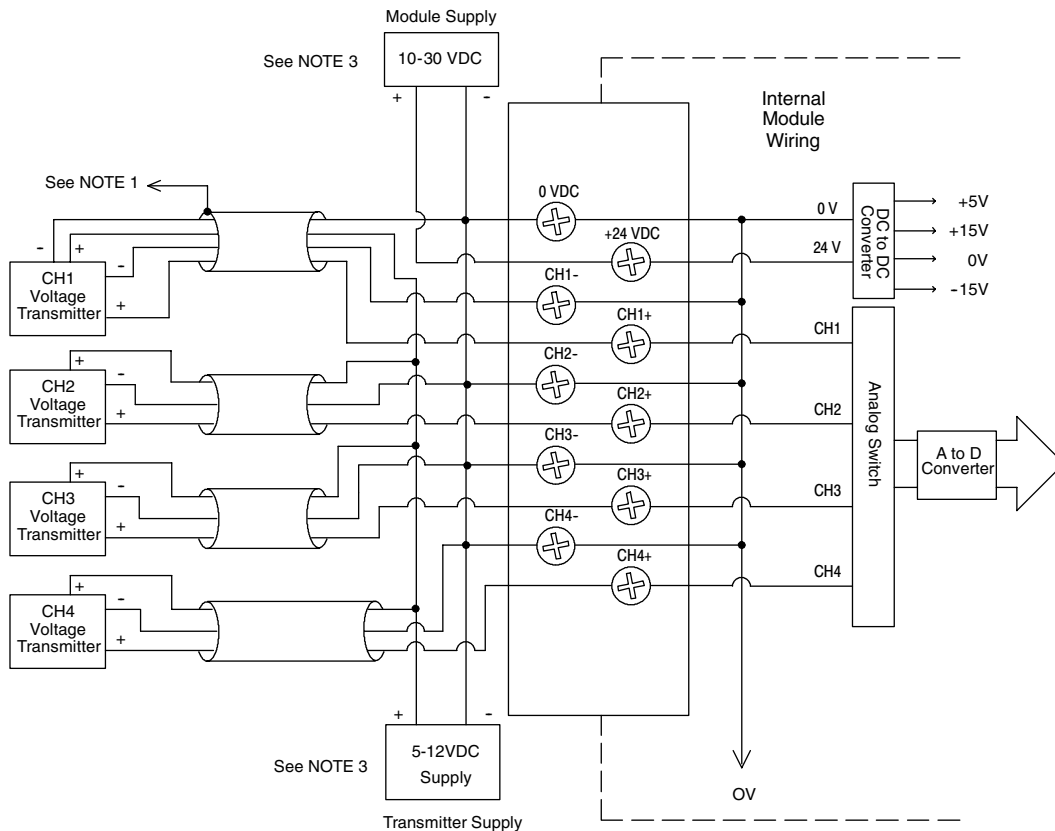

Analog Voltage Input Modules

F2-08AD-2 8-Channel Voltage Analog In \$525.00	
Number of Channels	8, single ended (1 common)
Input Ranges	0 to 5 V, 0 to 10V, ±5V, ±10VDC
Resolution	12 bit (1 in 4095) uni-polar 13 bit (-4095 to 4095) bi-polar
Active Low-pass Filtering	-3 dB at 200 Hz, (-6 dB per octave)
Input Impedance	>20 MΩ
Absolute Maximum Ratings	-75 to +75 VDC
Converter Type	Successive approximation
Conversion Time (PLC Update Rate)	8 channels per scan maximum (D2-262 CPU)
Linearity Error (End to End)	±1 count (0.025% of full scale) maximum
Input Stability	±1 count
Full Scale Calibration Error (offset error not included)	±3 counts maximum
Offset Calibration Error	±1 count maximum (0V input)
Step Response	1 ms to 95% of F.S. change

Includes circuitry to automatically detect broken or open transmitters.

Maximum Inaccuracy	±.1% @ 77 °F (25 °C) ±.3% 32 to 140 °F (0 to 60 °C)
Accuracy vs Temperature	±50 ppm / °C maximum full scale (including max. offset change of 2 counts)
Digital Input Points Required	16 (X) input points, (12 binary data bits, 3 channel ID bits, 1 sign bit, 1 diagnostic bit)
Base Power Required 5VDC	100 mA
External Power Supply	5 mA maximum, +10 to +30 VDC
Operating Temperature	32 to 140 °F (0 to 60 °C)
Storage Temperature	-4 to +158 °F (-20 to +70 °C)
Relative Humidity	5 to 95% (non-condensing)
Environmental Air	No corrosive gases permitted
Vibration	MIL STD 810C 514.2
Shock	MIL STD 810C 516.2
Noise Immunity	NEMA ICS3-304
Terminal Type (included)	Removable; D2-8IOCON



See Wiring Solutions for part numbers of **ZIPLink** cables and connection modules compatible with this I/O module.

Typical user wiring

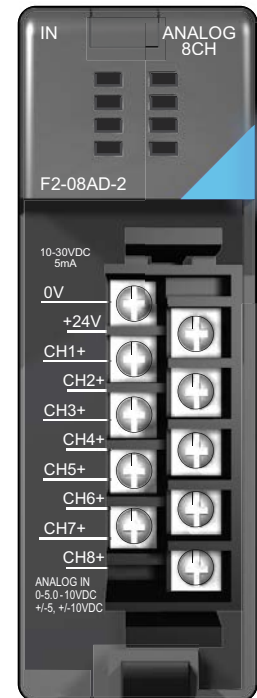
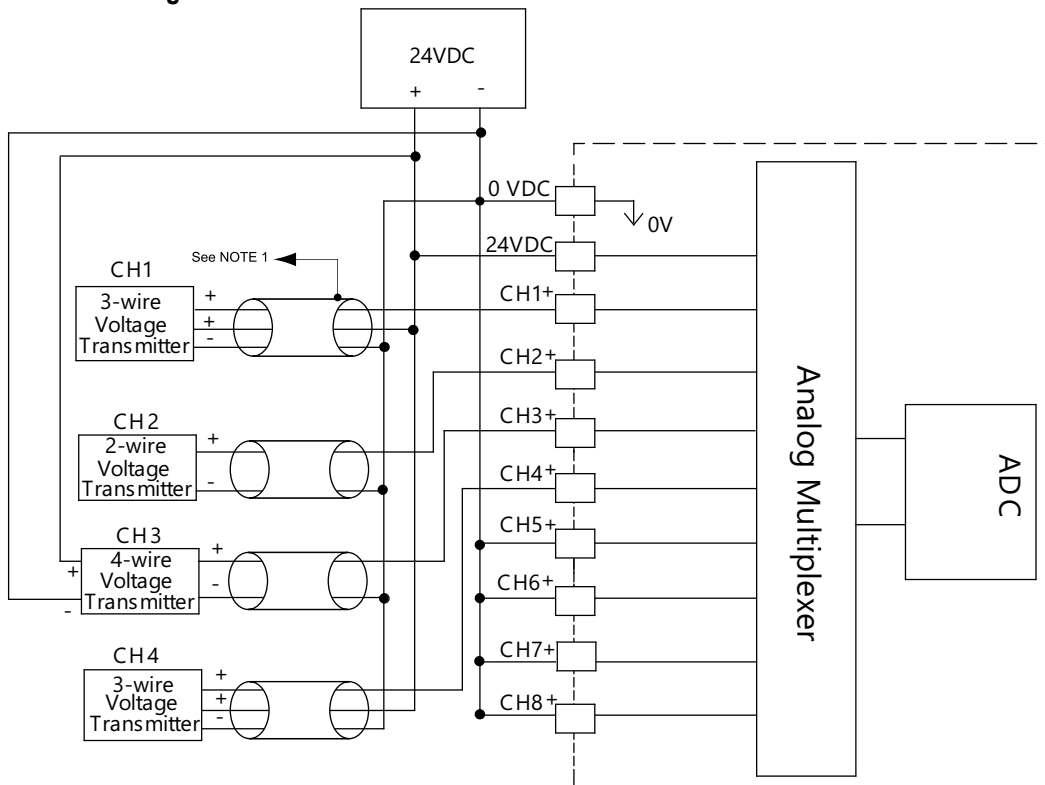

- Note 1: Shields should be grounded at the signal source.
- Note 2: Connect all external power supply commons.
- Note 3: Connect unused channels (CH5+, CH6+, CH7+, CH8+ in this example) to 0 VDC.

Temperature Input Modules

F2-04RTD 4-Channel RTD In \$539.00	
Number of Channels	4
Input Ranges	Type Pt100: -200.0 to +850.0 °C, -328 to +1562 °F Type Pt1000: -200.0 to +595.0°C, -328 to +1103 °F Type jPt100: -38.0 to +450.0°C, -36 to +842 °F Type Cu-10Ω/Cu-25Ω: -200.0 to +260.0 °C, -328 to +500 °F
Resolution	16 bit (1 in 65535)
Display Resolution	±0.1 °C, ±0.1 °F (±3276.7)
RTD Excitation Current	210 µA
Input Type	Differential
Notch Filter	>50 dB notches at 50 / 60 Hz -3 dB = 13.1 Hz
Maximum Setting Time	100ms (full-scale step input)
Common Mode Range	0-5 VDC
Absolute Maximum Ratings	Fault protected inputs to ±50 VDC
Sampling Rate	160 ms per channel

Converter Type	Charge Balancing
Linearity Error	±.05 °C maximum, ±.01 °C typical
Maximum Inaccuracy	Type Pt100, Pt1000, jPt100: ±1 °C Type Cu-10Ω/Cu-25Ω: ±5°C
PLC Update Rate	4 channel/scan max., <u>D2-262</u> CPU
Digital Input Points Required	32 input points (16 binary data bits, 2 channel ID bits, 4 fault bits)
Base Power Required 5VDC	90A
Operating Temperature	32 to 140 °F (0 to 60 °C)
Storage Temperature	-4 to +158 °F (-20 to +70 °C)
Temperature Drift	None (self-calibrating)
Relative Humidity	5% to 95% (non-condensing)
Environmental Air	No corrosive gases permitted
Vibration	MIL STD 810C 514.2
Shock	MIL STD 810C 516.2
Noise Immunity	NEMA ICS3-304
Terminal Type (included)	Removable; <u>D2-8IOCON</u>

Typical user wiring

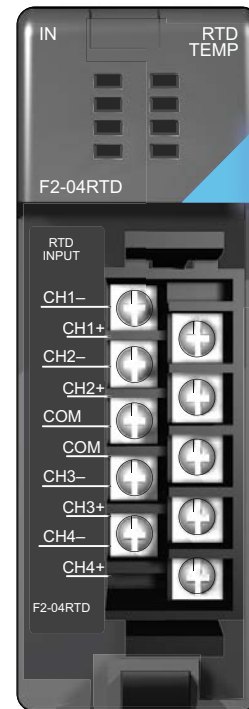
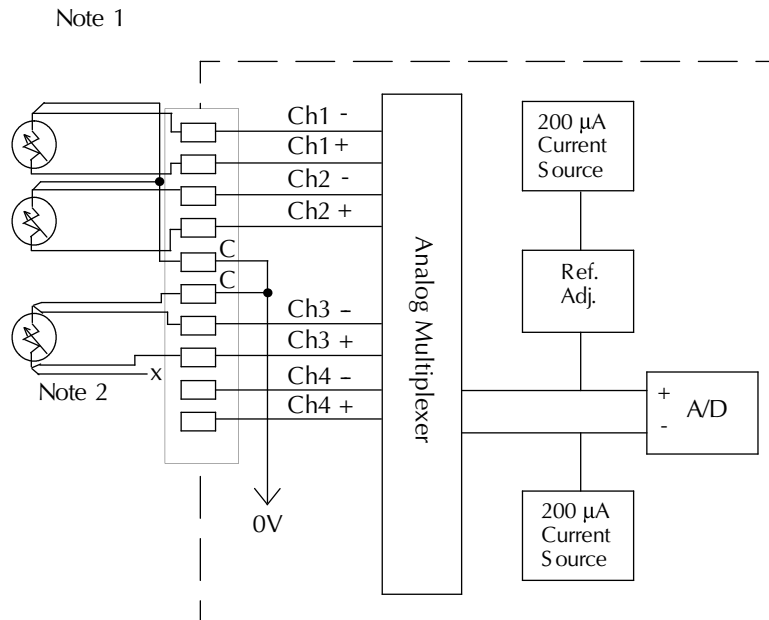

Notes:

1. The three wires connecting the RTD to the module must be the same type and length. Do not use the shield or drain wire for the third connection.
2. If an RTD sensor has four wires, the plus sense wire should be left unconnected as shown.
3. This module is not compatible with the ZIPLink wiring systems.

Temperature Input Modules

F2-04THM 4-Channel Thermocouple In \$582.00	
General Specifications	
Number of Channels	4, differential
Common Mode Range	±5 VDC
Common Mode Rejection	90 dB min. @ DC, 150 dB min. @ 50 / 60 Hz.
Input Impedance	1 MΩ
Absolute Maximum Ratings	Fault-protected inputs to ±50 VDC
Accuracy vs. Temperature	±5 ppm/°C maximum full scale calibration (including maximum offset change)
PLC Update Rate	4 channels per scan max. D2-262 CPU
Digital Input Points Required	32 (X) input points (16 binary data bits, 2 channel ID bits, 4 diagnostic bits)
External Power Supply	60 mA maximum, 18 to 26.4 VDC
Base Power Required 5VDC	110 mA
Operating Temperature	32 to 140 °F (0 to 60 °C)
Storage Temperature	-4 to +158°F (-20 to +70 °C)
Relative Humidity	5 to 95% (non-condensing)
Environmental Air	No corrosive gases permitted
Vibration	MIL STD 810C 514.2
Shock	MIL STD 810C 516.2
Noise Immunity	NEMA ICS3-304
Terminal Type (included)	Non-removable

Thermocouple Specifications	
Input Ranges	Type J -190 to +760 °C -310 to +1400 °F
	Type E -210 to +1000 °C -346 to +1832 °F
	Type K -150 to +1372 °C -238 to +2502 °F
	Type R 65 to 1768 °C 149 to 3214 °F
	Type S 65 to 1768 °C 149 to 3214 °F
	Type T -230 to +400 °C -382 to +752 °F
	Type B 529 to 1820 °C 984 to 3308 °F
	Type N -70 to +1300 °C -94 to +2372 °F
	Type C 65 to 2320 °C 149 to 4208 °F
	Display Resolution
Cold Junction Compensation	Automatic
Conversion Time	100ms per channel
Warm-Up Time	30 minutes typically ± 1°C repeatability
Linearity Error (End to End)	±.05°C maximum, ±.01°C typical
Maximum Inaccuracy	±3°C (excluding thermocouple error)
Voltage Input Specifications	
Voltage Ranges	0–5V, ±5V, 0–156.25 mV, ±156.25 mVDC
Resolution	16-bit (1 in 65535)
Full Scale Calibration Error (Offset Error Included)	±13 counts typical ±33 maximum
Offset Calibration Error	±1 count maximum, @ 0V input
Linearity Error (End to End)	±1 count maximum
Maximum Inaccuracy	±0.02% @ 25 °C (77 °F)

CPU Firmware Required	
CPU	Firmware Required
D2-250	V1.06
D2-250-1	All firmware versions work
D2-262	Version 1.0 or later

Thermocouple input wiring diagram

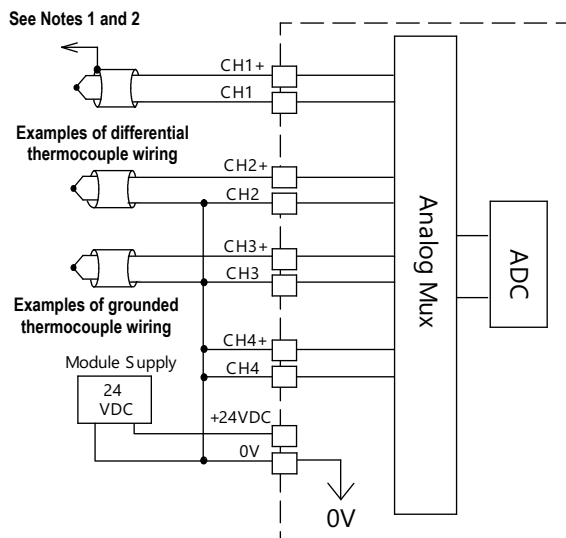

Voltage input wiring diagram

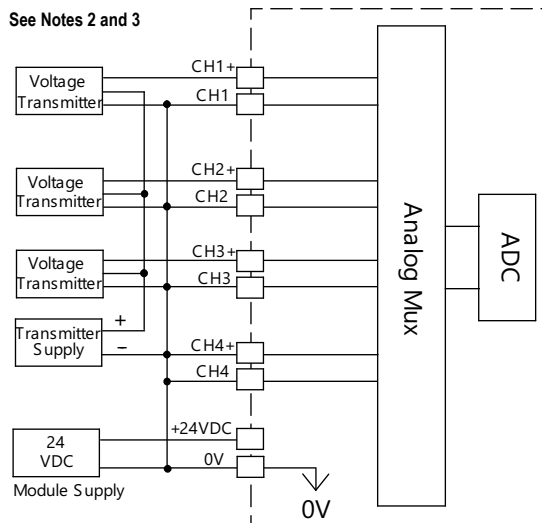

- Notes:**
- 1: Terminate shields at the respective signal source.
 - 2: Connect unused channels to a common terminal (0V, CH4+, CH4).
 - 3: When using 0-156 mV and 5V ranges, connect (-) or (0) volts terminal to 0V to ensure common mode range acceptance.
 - 4: This module is not compatible with the ZIPLink wiring system.

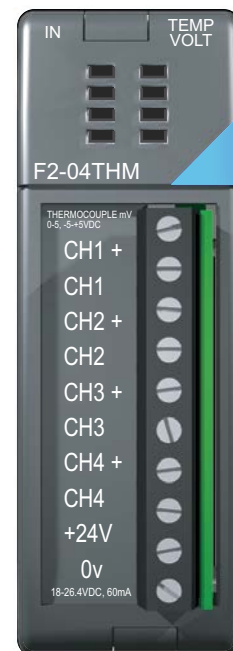

Analog Current Output Modules

F2-02DA-1 2-Channel 4-20mA Analog Output \$282.00

This module requires a 24 VDC user power supply for operation.

Number of Channels	2
Output Ranges	4 to 20 mA
Resolution	12-bit (1 in 4096)
Output Type	Single ended, one common
Digital Output Points Required	16 (Y) output points (12 binary data bits, 2 channel ID bits)
Maximum Loop Supply	30 VDC
Peak Output Voltage	40 VDC (clamped by transient voltage suppressor)
Load Impedance	Zero Ω minimum
Maximum Load/Power Supply	620 Ω /18V, 910 Ω /24V, 1200 Ω /30V
PLC Update Rate	2 channels per scan maximum (D2-262 CPU)
Linearity Error (end to end)	± 1 count ($\pm 0.025\%$ of full scale) maximum
Conversion Settling Time	100 μ s maximum (full scale change)
Full Scale Calibration Error (offset error included)	± 5 counts max., 20mA @ 77 °F (25 °C)
Offset Calibration Error	± 3 counts max., 4mA @ 77 °F (25C°)

Accuracy vs. Temperature	± 50 ppm/ $^{\circ}$ C full scale calibration change (including maximum offset change of 2 counts)
Maximum Inaccuracy	0.1% @ 77 °F (25 °C) 0.3% @ 32 to 140 °F (0 to 60 °C)
Base Power Required 5VDC	40 mA
External Power Supply	24 VDC, 60 mA. (add 20 mA for each current loop used)
Operating Temperature	32 to 140 °F (0 to +60 °C)
Storage Temperature	-4 to 158 °F (-20 to +70° C)
Relative Humidity	5% to 95% (non-condensing)
Environmental Air	No corrosive gases permitted
Vibration	MIL STD 810C 514.2
Shock	MIL STD 810C 516.2
Noise Immunity	NEMA ICS3-304
Terminal Type (included)	Removable; D2-8IOCON

See Wiring Solutions for part numbers of ZIPLink cables and connection modules compatible with this I/O module.



NOTE 1: Shields should be connected to the 0V of the module or the 0V of the R/S.

NOTE 2: Unused current outputs should remain open (no connections) for minimum power consumption.

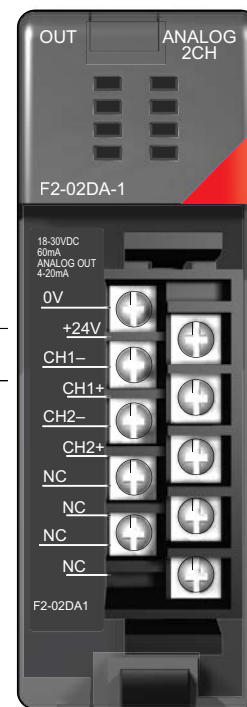
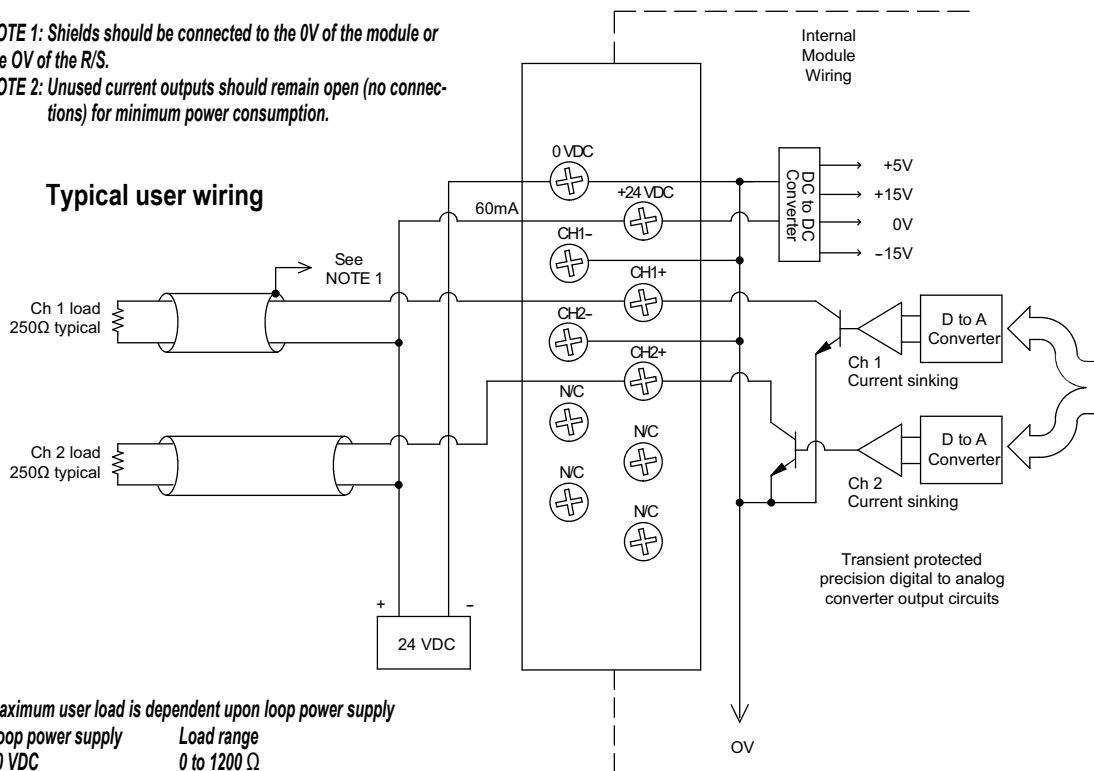

Maximum user load is dependent upon loop power supply

Loop power supply	Load range
30 VDC	0 to 1200 Ω
24 VDC	0 to 910 Ω
18VDC	0 to 620 Ω

Analog Current Output Modules

F2-02DAS-1 2-Channel Isolated 4-20mA Analog Output \$440.00	
Number of Channels	2, isolated
Output Ranges	4 to 20 mA
Resolution	16 bit (1 in 65536)
Output Type	Current sourcing
Digital Output Points Required	32 (Y) output points (16 binary data bits, 2 channel ID bits, 1 output enable bit)
Isolation Voltage	±750V continuous, channel to channel, channel to logic
Base Power Required 5VDC	100mA
Loop Supply	18-32 VDC
External Power Supply	18-32 VDC @ 50 mA per channel
Output Loop Compliance	Vin - 2.5 V
Max Load Impedance	525Ω
Maximum Load/ Power Supply	375Ω/12V, 975Ω/24V, 1375Ω/32V
PLC Update Rate	2 channels per scan maximum (D2-262 CPU)
Conversion Settling Time	3ms to 0.1% of full scale

Linearity Error (end to end)	±10 count (±0.015% of full scale) maximum
Gain Calibration Error	±32 counts (±0.05%)
Offset Calibration Error	±13 counts (±0.02%)
Output Drift	50 ppm/°C
Maximum Inaccuracy	0.07% @ 25 °C (77 °F) 0.18% 0 to 60 °C (32 to 140 °F)
Operating Temperature	0 to 60 °C (32° to 140 °F)
Storage Temperature	-20 to +70°C (-4° to +158 °F)
Relative Humidity	5% to 95% (non-condensing)
Environmental air	No corrosive gases permitted
Vibration	MIL STD 810C 514.2
Shock	MIL STD 810C 516.2
Noise Immunity	NEMA ICS3-304
Terminal Type (included)	Removable; D2-8IOCON

See Wiring Solutions for part numbers of ZIPLink cables and connection modules compatible with this I/O module.



Typical user wiring

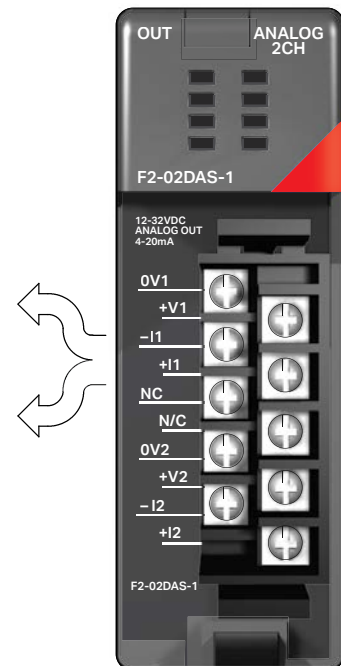
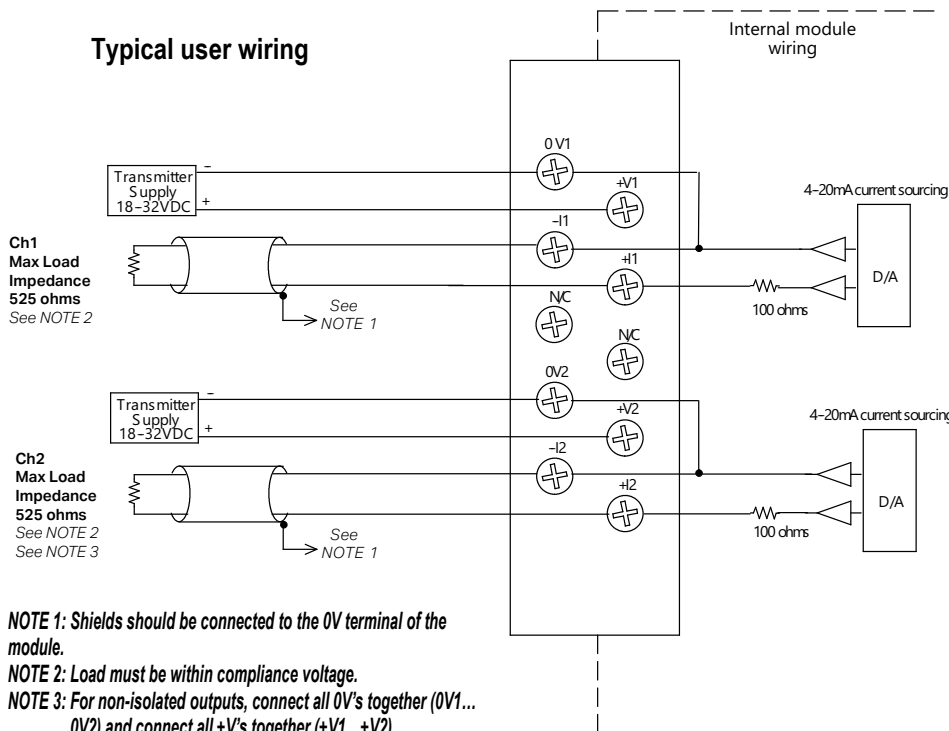

Analog Current Output Modules

F2-08DA-1 8-Channel 4-20mA Analog Output \$535.00	
Number of Channels	8, single-ended
Output Ranges	4 to 20 mA
Resolution	12-bit (1 in 4096)
Output Type	Current sinking or current sourcing
Digital Output Points Required	16 (Y) output points (12 binary data bits, 3 channel ID bits, 1 output enable bit)
Base Power Required 5VDC	30mA
Maximum Loop Voltage	30 VDC
External Power Supply	18 to 30 VDC, 50 mA., class 2 (add 20mA for each current loop used)
Source Load	0-400 Ω @ 18-30 VDC
Sink Load	0-600 Ω/18V, 0-900 Ω/24V, 0-1200 Ω/30V
Total Load (sink + source)	600Ω/18V, 900Ω/24 V, 1200Ω/30V
PLC Update Rate	8 channels per scan maximum (D2-262 CPU)
Conversion Settling Time	400µs maximum (full scale change)

Linearity Error (end to end)	±2 count (±0.050% of full scale) maximum
Full Scale Calibration Error	± 12 counts max. sinking @ any load ± 12 counts max. sourcing @ 125Ω load ± 18 counts max. sourcing @ 250Ω load ± 26 counts max. sourcing @ 400Ω load
Offset Calibration Error	± 9 counts max. sinking @ any load ± 9 counts max. sourcing @ 125Ω load ± 11 counts max. sourcing @ 250Ω load ± 13 counts max. sourcing @ 400Ω load
Maximum Full Scale Inaccuracy @ 60°C	0.5% sinking (any load) sinking & sourcing @ 125Ω load 0.64% sourcing @ 250Ω load 0.83% sourcing @ 400Ω load
Maximum Full Scale Inaccuracy @ 25°C (Includes all errors and temp drift)	0.3% sinking (any load) sinking & sourcing @ 125Ω load 0.44% sourcing @ 250Ω load 0.63% sourcing @ 400Ω load
Operating Temperature	32 to 140 °F (0 to 60 °C)
Storage Temperature	-4 to 158°F(-20 to +70 °C)
Relative Humidity	5% to 95% (non-condensing)
Environmental air	No corrosive gases permitted
Vibration	MIL STD 810C 514.2
Shock	MIL STD 810C 516.2
Noise Immunity	NEMA ICS3-304
Terminal Type (included)	Removable; D2-16IOCON

See Wiring Solutions for part numbers of ZIPLink cables and connection modules compatible with this I/O module.



Typical user wiring

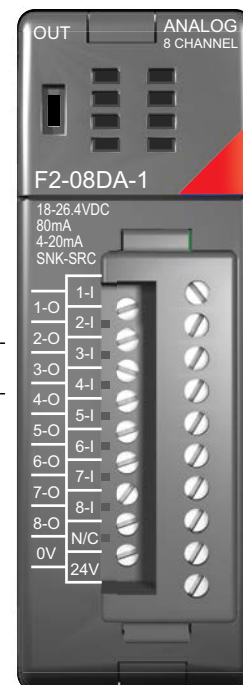
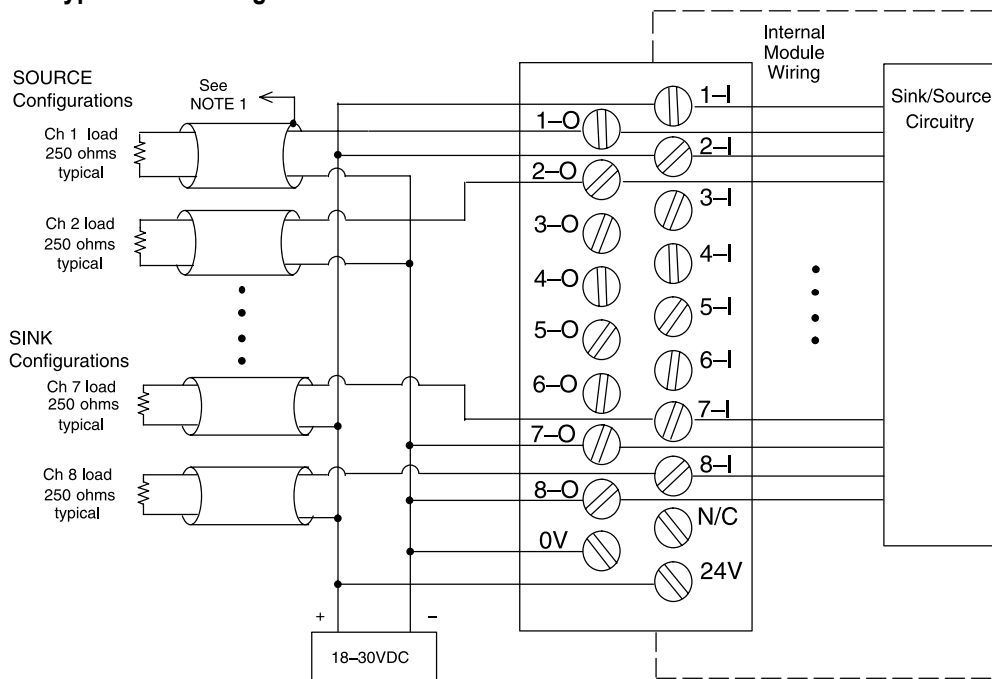

NOTE 1: Shields should be connected to the 0V of the module.

Analog Voltage Output Modules

F2-02DA-2 2-Channel Voltage Analog Output	
\$295.00	
This module requires a 24 VDC user power supply for operation. All other specifications are the same.	
Number of Channels	2
Output Ranges	0 to 5V, 0 to 10V, $\pm 5V$, $\pm 10V$
Resolution	12-bit (1 in 4096)
Output Type	Single ended, 1 common
Digital Output Points Required	16 (Y) output points (12 binary data bits, 2 channel ID bits)
Peak Output Voltage	15 VDC (clamped by transient voltage suppressor)
Load Impedance	2000 Ω minimum
Load Capacitance	0.01 μF maximum
PLC Update Rate	2 channels per scan, maximum (D2-262 CPU)
Linearity Error (end to end)	± 1 count (0.025% of full scale) maximum
Conversion Settling Time	5 μs maximum (full scale change)
Full Scale Calibration Error (offset error included)	± 12 counts max. unipolar @ 77 °F (25 °C) ± 16 counts max. bipolar @ 77 °F (25 °C)
Offset Calibration Error	± 3 counts max., unipolar @ 77 °F (25 °C) ± 8 counts max., bipolar @ 77 °F (25 °C)

Accuracy vs. Temperature	± 50 ppm/ $^{\circ}C$ full scale calibration change (including maximum offset change of 2 counts)
Maximum Inaccuracy	+0.3% unipolar ranges @ 77 °F (25 °C) $\pm 0.45\%$ unipolar ranges >77 °F (25 °C) $\pm 0.4\%$ bipolar ranges @ 77 °F (25 °C) $\pm 0.55\%$ bipolar ranges >77 °F (25 °C)
Base Power Required 5VDC	40 mA
External Power Supply	24 VDC, 60 mA (outputs fully loaded)
Operating Temperature	32 to 140 °F (0 to 60 °C)
Storage Temperature	-4 to +158 °F (-20° to +70 °C)
Relative Humidity	5% to 95% (non-condensing)
Environmental Air	No corrosive gases permitted
Vibration	MIL STD 810C 514.2
Shock	MIL STD 810C 516.2
Noise Immunity	NEMA ICS3-304
Terminal Type (included)	Removable; D2-8IOCON

See Wiring Solutions for part numbers of ZIPLink cables and connection modules compatible with this I/O module.

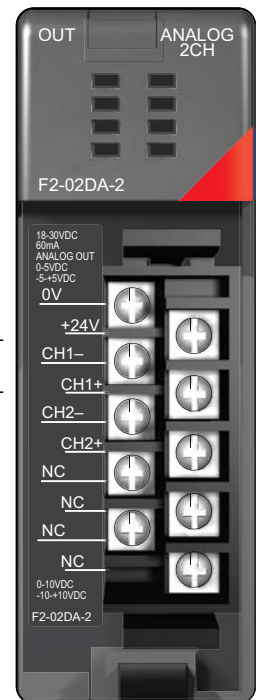
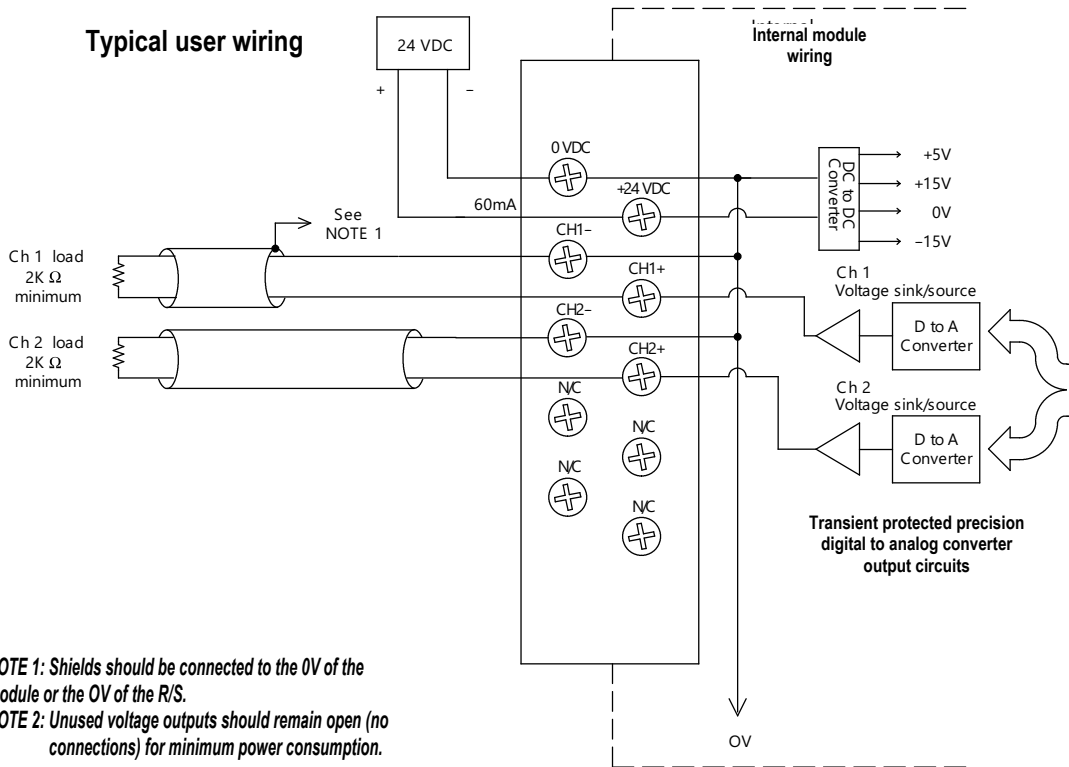

NOTE 1: Shields should be connected to the 0V of the module or the 0V of the R/S.
NOTE 2: Unused voltage outputs should remain open (no connections) for minimum power consumption.

Analog Voltage Output Modules

F2-02DAS-2 2-Channel 0-5V, 0-10V Isolated Analog Output \$479.00	
Number of Channels	2, isolated
Output Ranges	0-5V, 0-10V
Resolution	16-bit (1 in 65536)
Output Type	Sourced through external loop supply
Digital Output Points Required	32 (Y) output points (16 binary data bits, 2 channel ID bits)
Isolation Voltage	±750V continuous, channel to channel, channel to logic
Base Power Required 5VDC	60 mA
External Power Supply	21.6-26.4 VDC @ 60 mA per channel
Load Impedance	2 kΩ min.
PLC Update Rate	2 channels per scan, maximum (D2-262 CPU)
Conversion Settling Time	3 ms to 0.1% of full scale

Linearity Error (end to end)	±10 count (±0.015% of full scale) maximum
Gain Calibration Error	±32 counts (±0.05%)
Offset Calibration Error	±13 counts (±0.02%)
Output Drift	50 ppm/°C
Maximum Inaccuracy	0.07% @ 25 °C (77 °F) 0.18% 0 to 60°C (32 to 140 °F)
Operating Temperature	0 to 60°C (32 to 140 °F)
Storage Temperature	-20° to 70°C (-4° to +158 °F)
Relative Humidity	5 to 95% (non-condensing)
Environmental air	No corrosive gases permitted
Vibration	MIL STD 810C 514.2
Shock	MIL STD 810C 516.2
Noise Immunity	NEMA ICS3-304
Terminal Type (included)	Removable; D2-8IOCON

See Wiring Solutions for part numbers of ZIPLink cables and connection modules compatible with this I/O module.



Typical user wiring

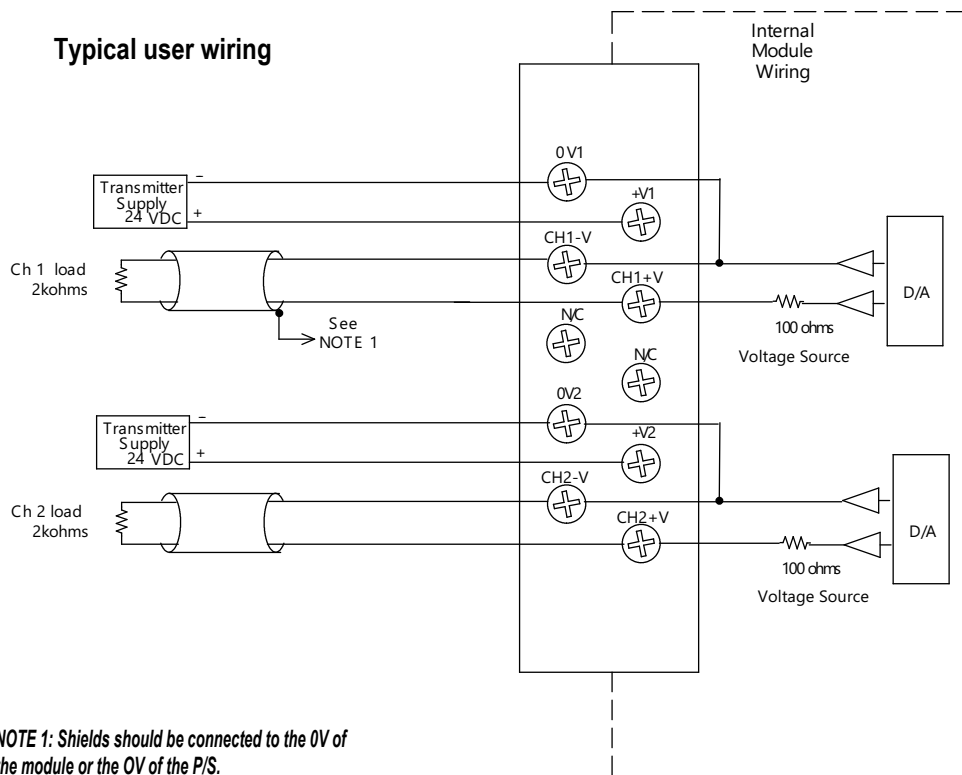

NOTE 1: Shields should be connected to the 0V of the module or the 0V of the P/S.

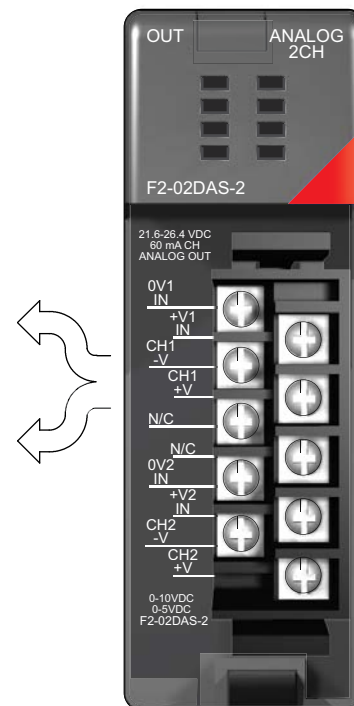

Analog Voltage Output Modules

F2-08DA-2 8-Channel Voltage Analog Output	
\$530.00	
Number of Channels	8, single-ended, 1 common
Output Ranges	0 to 5V, 0 to 10V
Resolution	12-bit (1 in 4096)
Output Type	Voltage sourcing
Digital Output Points Required	16 (Y) output points (12 binary data bits, 3 channel ID bits, 1 output enable bit)
Base Power Required 5VDC	60mA
External Power Supply	21.6-26.4 VDC, 140mA (outputs fully loaded)
Peak Output Voltage	15VDC (clamped by transient voltage suppressor)
Load Impedance	1-10kΩ
Load Capacitance	0.01 μF maximum
PLC Update Rate	8 channels per scan maximum (D2-262 CPU)
Conversion Settling Time	400μs maximum (full scale change) 4.5 ms to 9ms for digital out to analog out

Linearity Error (end to end)	±1 count (±0.025% of full scale) maximum
Full Scale Calibration Error	±12 counts max. unipolar @ 25 °C (77 °F)
Offset Calibration Error	±3 counts max., unipolar @ 25 °C (77 °F)
Accuracy vs. Temperature	±57 ppm/°C full scale calibration change (including maximum offset change of 2 counts)
Maximum Inaccuracy	±0.3% @ 25 °C (77 °F) ±0.45% @ 0-60°C (32 to 140 °F)
Operating Temperature	0° to 60°C (32 to 140 °F)
Storage Temperature	-20° to 70°C (-4 to +158°F)
Relative Humidity	5 to 95% (non-condensing)
Environmental air	No corrosive gases permitted
Vibration	MIL STD 810C 514.2
Shock	MIL STD 810C 516.2
Noise Immunity	NEMA ICS3-304
Terminal Type (included)	Removable; D2-8IOCON

See Wiring Solutions for part numbers of **ZIPLink** cables and connection modules compatible with this I/O module.



Typical user wiring

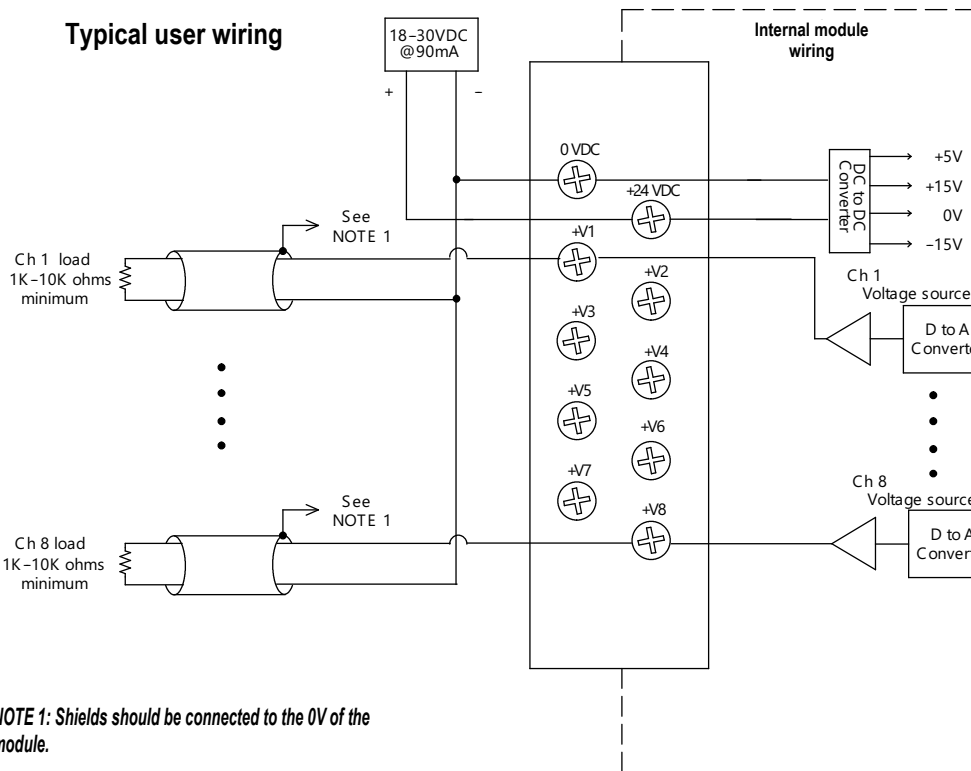

NOTE 1: Shields should be connected to the 0V of the module.

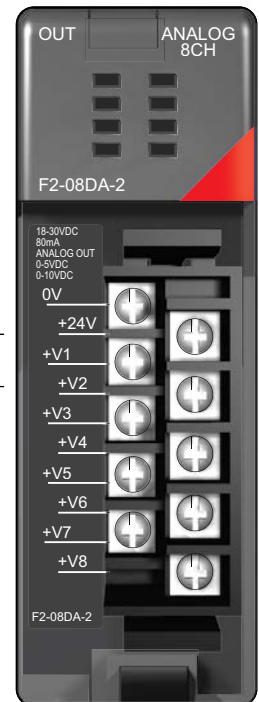

Analog In/Output Combination Module

F2-4AD2DA 4-Channel Analog Input 2-Channel Analog Output \$566.00	
Number of Input Channels	4, single-ended (1 common)
Number of Output Channels	2, single-ended (1 common)
Ranges	4 to 20 mA current (current sinking)
Resolution	12 bit (1 in 4096)
Peak Withstanding Voltage	75 VDC, current outputs
Maximum Continuous Overload	-40 to +40 mA, each current output
Input Impedance	250Ω, ±0.1%, 1/2 W, 25 ppm/°C current input resistance
External Load Resistance	0Ω minimum, current outputs
Maximum Loop Supply	30 VDC
Recommended Fuse	0.032 A, series 217 fast-acting, current inputs
Maximum Load/Power Supply	910Ω/24V, current outputs 620Ω/18V, 1200Ω/30V
Active Low-pass Filter	-3dB @ 20Hz, 2 poles (-12 dB per octave)
Linearity Error (best fit)	±1 count (±0.025% of full scale) maximum
Output Settling Time	100μs maximum (full scale change)

Accuracy vs. Temperature	±50 ppm/°C full scale calibration change (including maximum offset change)
Maximum Inaccuracy	±0.1% @ 77 °F (25 °C) ±0.3% @ 32 to 140 °F (0 to 60 °C)
Digital Input and Output Points Required	16 (X) input points (12 binary data bits, 2 channel ID bits, 2 diagnostic bits) 16 (Y) output points (12 binary data bits, 2 channel enable bits)
PLC Update Rate	4 channels per scan maximum: (D2-250-1 and D2-262 CPUs) 2 output channels per scan maximum: (D2-262 CPU)
Base Power Required 5VDC	90 mA
External Power Supply Requirement	18-26.4 VDC @ 80 mA 20mA per loop
Operating Temperature	32 to 140 °F (0 to 60 °C)
Storage Temperature	-4 to +158 °F (-20 to +70 °C)
Relative Humidity	5 to 95% (non-condensing)
Environmental Air	No corrosive gases permitted
Vibration	MIL STD 810C 514.2
Shock	MIL STD 810C 516.2
Noise Immunity	NEMA ICS3-304
Terminal Type (included)	Removable; D2-8IOCON

See Wiring Solutions for part numbers of ZIPLink cables and connection modules compatible with this I/O module.



- Note 1: Shields should be connected at their respective signal source.
- Note 2: Unused channel should remain open for minimum power consumption.
- Note 3: More than one external power supply can be used provided the power supply commons are connected.
- Note 4: A Series 217, 0.032 A fast-acting fuse is recommended for 4-20 mA current input loops.
- Note 5: If the power supply common of an external power supply is not connected to 0 VDC on the module, then the output of the external transmitter must be isolated. To avoid "ground loop" errors, recommended 4-20 mA transmitter types are:
 2 or 3 wire: isolation between input signal and power supply
 4 wire: isolation between input signal, power supply, and 4-20 mA output.

- Note 6: If an analog channel is connected backwards, then erroneous data values will be returned for that channel.
- Note 7: To avoid small errors due to terminal block losses, connect 0 VDC, IN-, and OUT- on the terminal block as shown. The module's internal connection alone of these nodes is not sufficient to permit module performance up to the accuracy specifications.
- Note 8: Choose an output transducer resistance according to the maximum load/power listed in the Output Specifications.

Typical user wiring

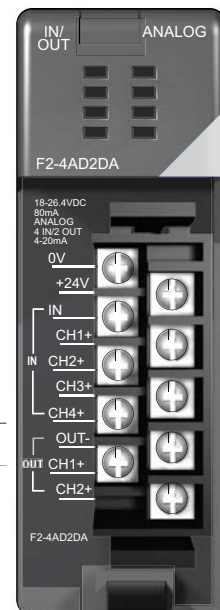
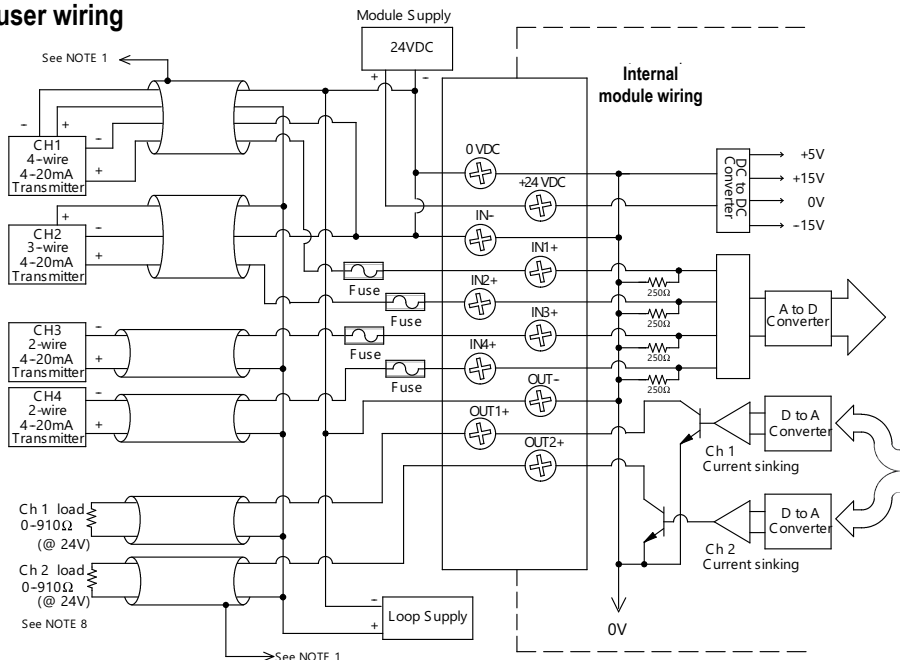

Analog In/Output Combination Module

Requires D2-250-1 or D2-262 CPU.

F2-8AD4DA-1 8-Channel Analog Current Input 4-Channel Analog Current Output \$710.00	
Input Channels per Module	8, single ended (one common)
Input Range	0 to 20 mA
Resolution	12, 14, 16-bit selectable
External DC Power Required	100 mA @ 18-26.4 VDC
Max. Continuous Overload	±45 mA
Input Impedance	100Ω 0.1% 1/4 W
Filter Characteristics	Active low pass, -3 dB @ 80 Hz
Conversion Time	12-bit = 1.5 ms per channel 14-bit = 6 ms per channel 16-bit = 25 ms per channel
Conversion Method	Over sampling successive approximation
Accuracy vs. Temperature	±25 ppm / °C Max.
Maximum Inaccuracy	0.1% of range
Linearity Error (End to End)	12-bit = ±2 count max. (±0.06% of range) 14-bit = ±10 count max. (±0.06% of range) 16-bit = ±20 count max. (±0.06% of range) Monotonic with no missing codes
Full Scale Calibration Error (not including offset error)	±0.07% of range max.
Offset Calibration Error	±0.03% of range max.
Rec. Fuse (external)	0.032A, Littelfuse Series 217 fast-acting
Base Power Required 5VDC	35mA

Output Channels per Module	4
Output Range	4 to 20 mA
Resolution	16-bit, 0.244 mA/bit
Output Type	Current sourcing at 20 mA, max.
Load Impedance	0-750 Ω
Max. Inaccuracy	0.25% of range
Max. Full Scale Calibration Error (not incl. offset error)	±0.075% of range max.
Max. Offset Calibration Error	±0.1% of range max.
Accuracy vs. Temperature	±25 ppm / °C max. full scale calibration change (± 0.0025% of range / °C)
Max. Crosstalk at DC, 50/60 Hz	-70 dB, 1 LSB
Linearity Error (End to End)	±1 count max. (±0.025% of full scale) Monotonic with no missing codes
Output Stability and Repeatability	±1 LSB after 10 minute warm-up typical
Output Ripple	0.005% of full scale
Output Settling Time	0.5 ms max., 5 μs, min. (full scale change)
Max. Continuous Overload	Outputs open circuit protected
Type of Output Protection	Electronically current limited to 20 mA or less
Output Signal at Power-up and Power-down	4 mA
Terminal Type (included)	Removable; D2-16IOCON

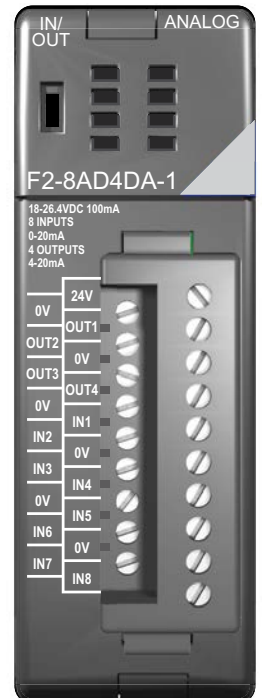
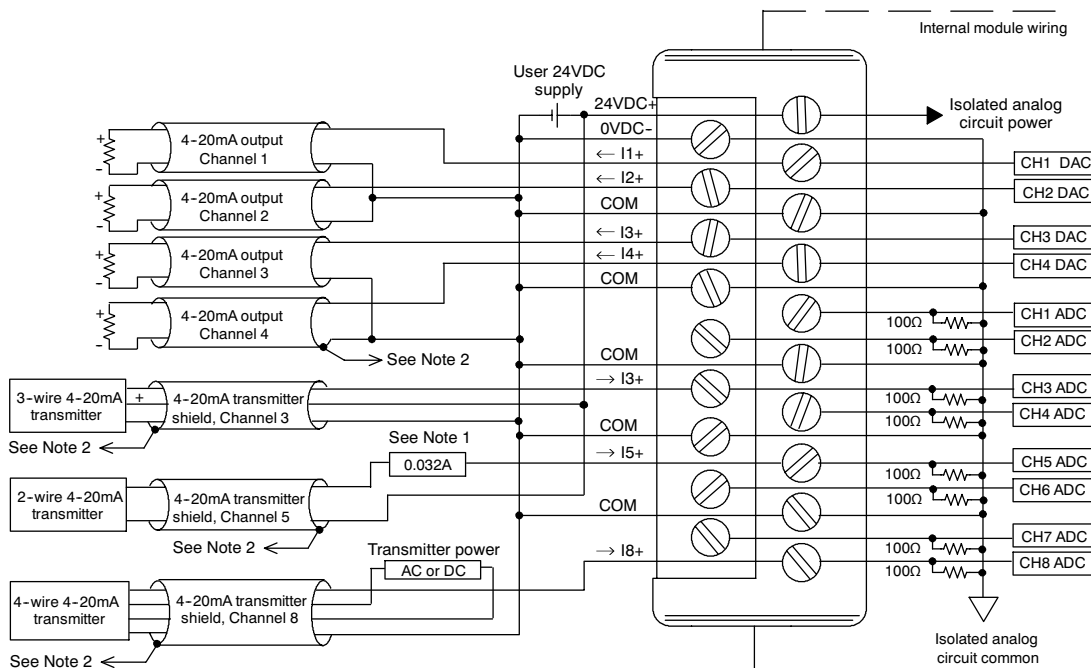

Note 1: A Littelfuse Series 217, 0.032A fast-acting fuse is recommended for all 4-20mA current loop inputs.

Note 2: Connect shields to the 0V of the module; do not connect both ends of shield.

Analog In/Output Combination Module

Requires D2-250-1 or D2-262 CPU.

F2-8AD4DA-2 8-Channel Analog Voltage Input 4-Channel Analog Voltage Output \$701.00	
Input Channels per Module	8, single ended (one common)
Input Range	0 to 10V
Resolution	12, 14, 16-bit selectable
External DC Power Required	80 mA @ 18-26.4 VDC
Max. Continuous Overload	±100V
Input Impedance	>10 MΩ
Filter Characteristics	Active low pass, -3 dB @ 80 Hz
Conversion Time	12-bit = 1.5 ms per channel 14-bit = 6 ms per channel 16-bit = 25 ms per channel
Conversion Method	Over sampling successive approximation
Accuracy vs. Temperature	±50 ppm/°C Max.
Maximim Inaccuracy	0.1% of range
Linearity Error (End to End)	12-bit = ±1 count max. (±0.025% of range) 14-bit = ±4 count max. (±0.025% of range) 16-bit = ±16 count max. (±0.025% of range) Monotonic with no missing codes
Full Scale Calibration Error (not including offset error)	±0.075% of range max.
Offset Calibration Error	±0.025% of range max.
Base Power Required 5VDC	35 mA

Output Channels per Module	4
Output Range	0-5V, 0-10V
Resolution	16-bit
Output Type	Voltage sourcing/sinking at 10 mA max.
Load Impedance	>1000Ω
Max. Inaccuracy	0.15% of range
Max. Full Scale Calibration Error (not incl. offset error)	±0.075% of range max.
Max. Offset Calibration Error	±0.025% of range max.
Accuracy vs. Temperature	±50 ppm/°C max. full scale calibration change (± 0.005% of range /°C)
Max. Crosstalk @ DC, 50/60 Hz	-70 dB, 1 LSB
Linearity Error (End to End)	±1 count max. (±0.025% of full scale) Monotonic with no missing codes
Output Stability and Repeatability	±1 LSB after 10 minute warm-up typical
Output Ripple	0.005% of full scale
Output Settling Time	0.5 ms max., 5 μs min. (full scale change)
Max. Continuous Overload	Outputs current limited to 15 mA typical
Type of Output Protection	1 VDC peak output voltage (clamped by transient voltage suppressor)
Output Signal at Power-up and Power-down	0V
Terminal Type (included)	Removable; D2-16IOCON

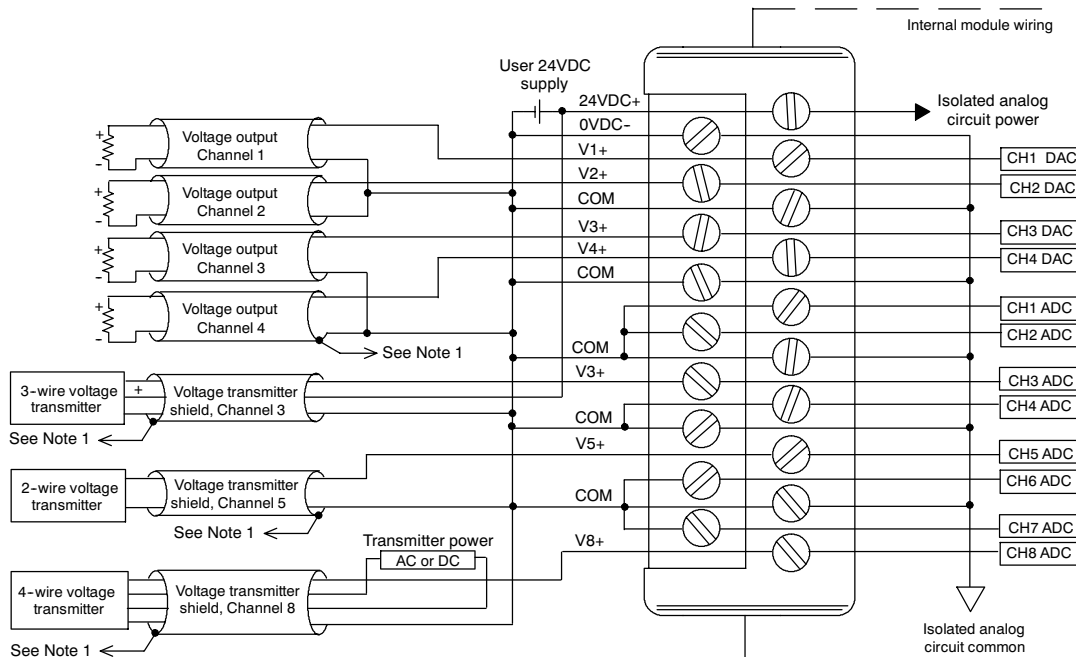

Note 1: Connect shields to the 0V of the module; do not connect both ends of shield.

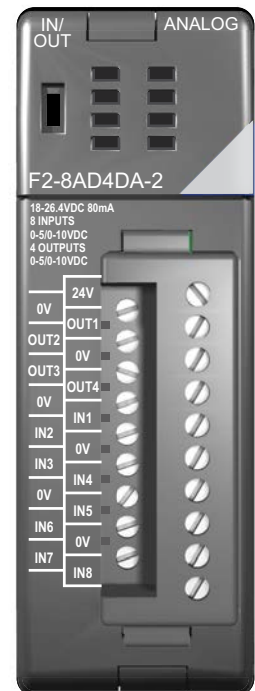

ZIPLINK™ Wiring Solutions

AUTOMATIONDIRECT

Wiring Solutions using the ZIPLink Wiring System

ZIPLinks eliminate the normally tedious process of wiring between devices by utilizing prewired cables and DIN rail mount connector modules. It's as simple as plugging in a cable connector at either end or terminating wires at only one end. Prewired cables keep installation clean and efficient, using half the space at a fraction of the cost of standard terminal blocks. There are several wiring solutions available when using the ZIPLink System ranging from PLC I/O-to-ZIPLink Connector Modules that are ready for field termination, options for connecting to third party devices, GS, DuraPulse and SureServo Drives, as well as special relay, transorb and communications modules. Pre-printed I/O-specific adhesive label strips for quick marking of ZIPLink modules are provided with ZIPLink cables. See the following solutions to help determine the best ZIPLink system for your application.

Solution 1: Do-more, DirectLOGIC, CLICK and Productivity Series I/O Modules to ZIPLink Connector Modules

When looking for quick and easy I/O-to-field termination, a ZIPLink connector module used in conjunction with a prewired ZIPLink cable, consisting of an I/O terminal block at one end and a multi-pin connector at the other end, is the best solution.



Using the PLC I/O Modules to ZIPLink Connector Modules selector tables located in this section,

1. Locate your I/O module/PLC
2. Select a **ZIPLink** Module
3. Select a corresponding **ZIPLink** Cable.

Solution 2: Do-more, DirectLOGIC, CLICK and Productivity Series I/O Modules to 3rd Party Devices

When wanting to connect I/O to another device within proximity of the I/O modules, no extra terminal blocks are necessary when using the ZIPLink Pigtail Cables. ZIPLink Pigtail Cables are prewired to an I/O terminal block with color-coded pigtail with soldered-tip wires on the other end.



Using the I/O Modules to 3rd Party Devices selector tables located in this section,

1. Locate your PLC I/O module
2. Select a **ZIPLink** Pigtail Cable that is compatible with your 3rd party device.

Solution 3: GS Series and DuraPulse Drives Communication Cables

Need to communicate via Modbus RTU to a drive or a network of drives?

ZIPLink cables are available in a wide range of configurations for connecting to PLCs and SureServo, SureStep, Stellar Soft Starter and AC drives. Add a ZIPLink communications module to quickly and easily set up a multi-device network.

Using the Drives Communication selector tables located in this section,

1. Locate your Drive and type of communications
2. Select a **ZIPLink** cable and other associated hardware.



ZIPLINK™ Wiring Solutions

AUTOMATIONDIRECT

Solution 4: Serial Communications Cables

ZIPLink offers communications cables for use with **DirectLOGIC**, CLICK, and Productivity CPUs, that can also be used with other communications devices. Connections include a 6-pin RJ12 or 9-pin, 15-pin and 25-pin D-sub connectors which can be used in conjunction with the RJ12 or D-Sub feedthrough modules.

Using the Serial Communications Cables selector table located in this section,

1. Locate your connector type
2. Select a cable.



Solution 5: Specialty ZIPLink Modules

For additional application solutions, **ZIPLink** modules are available in a variety of configurations including stand-alone relays, 24 VDC and 120 VAC transorb modules, D-sub, RJ12 and RJ45 feedthrough modules, communication port adapter and distribution modules, and SureServo 50-pin I/O interface connection.

Using the **ZIPLink** Specialty Modules selector table located in this section,

1. Locate the type of application
2. Select a **ZIPLink** module.



Solution 6: ZIPLink Connector Modules to 3rd Party Devices

If you need a way to connect your device to terminal blocks without all that wiring time, then our pigtail cables with color-coded soldered-tip wires are a good solution. Used in conjunction with any compatible **ZIPLink** Connector Modules, a pigtail cable keeps wiring clean and easy and reduces troubleshooting time.

Using the Universal Connector Modules and Pigtail Cables table located in this section,

1. Select module type
2. Select the number of pins
3. Select cable.





PLC I/O Modules to ZIPLink Connector Modules – Do-more!/DL205

Do-more / DL205 PLC Input Module ZIPLink Selector				
PLC	ZIPLink			
Input Module	# of Terms	Component	Module Part No.	Cable Part No. †
D2-08ND3	10	Feedthrough	ZL-RTB20 (-1)	ZL-D2-CBL10 *
D2-16ND3-2	19	Feedthrough		ZL-D2-CBL19
		Sensor	ZL-LTB16-24-1	ZL-D2-CBL19-1 ZL-D2-CBL19-2
D2-32ND3 1	40	Feedthrough	ZL-RTB40 (-1)	180 deg conn: ZL-D24-CBL40
		Sensor	ZL-LTB32-24-1	ZL-D24-CBL40-1 ZL-D24-CBL40-2
D2-32ND3-2 1	40	Feedthrough	ZL-RTB40(-1)	45 deg conn: ZL-D24-CBL40-X ZL-D24-CBL40-1X ZL-D24-CBL40-2X
		Sensor	ZL-LTB32-24-1	
D2-08NA-1	10	Feedthrough	ZL-RTB20 (-1)	ZL-D2-CBL10
D2-08NA-2	10			ZL-D2-CBL10-1
D2-16NA	19			ZL-D2-CBL10-2
				ZL-D2-CBL19 *

† X in the part number represents a 45° angle.

Do-more/DL205 PLC Combo In/Out Module ZIPLink Selector				
PLC	ZIPLink			
Combo Module	# of Terms	Component	Module Part No.	Cable Part No.
D2-08CDR	10	Feedthrough	ZL-RTB20 (-1)	ZL-D2-CBL10 *

Do-more/DL205 PLC Analog Module ZIPLink Selector					
PLC	ZIPLink				
Analog Module	# of Terms	Component	Module	Cable	
F2-04AD-1	10	Feedthrough	ZL-RTB20 (-1)	ZL-D2-CBL10 ZL-D2-CBL10-1 ZL-D2-CBL10-2	
F2-08AD-1					
F2-04AD-2					
F2-08AD-2					
F2-02DA-1					
F2-02DAS-1					
F2-08DA-1				ZL-D2-CBL19 ZL-D2-CBL19-1 ZL-D2-CBL19-2	
F2-02DA-2					
F2-02DAS-2					
F2-08DA-2					
F2-4AD2DA				19	ZL-D2-CBL19 ZL-D2-CBL19-1 ZL-D2-CBL19-2
F2-8AD4DA-1					
F2-8AD4DA-2					
F2-04RTD				Matched Only	These modules are not supported by the ZIPLink wiring system
F2-04THM					

Do-more/ DL205 PLC Output Module ZIPLink Selector				
PLC	ZIPLink			
Output Module	# of Terms	Component	Module Part No.	Cable Part No. †
D2-04TD1 2	10	Feedthrough	ZL-RTB20 (-1)	ZL-D2-CBL10
D2-08TD1				ZL-D2-CBL10-1
D2-08TD2				ZL-D2-CBL10-2
D2-16TD1-2	19	Feedthrough	ZL-RTB20 (-1)	ZL-D2-CBL19 ZL-D2-CBL19-1 ZL-D2-CBL19-2
		Fuse		
Feedthrough		ZL-RFU20 4		
Relay		ZL-RRL16-24-2 ZL-RRL16W-24-2 ZL-RRL16F-24-2 ZL-RRL16HDF-24-2		
F2-16TD1P	19	Feedthrough	ZL-RTB20 (-1)	
F2-16TD2P				
D2-32TD1 1	40	Feedthrough	ZL-RTB40 (-1)	180 deg conn: ZL-D24-CBL40 ZL-D24-CBL40-1 ZL-D24-CBL40-2
		Fuse	ZL-RFU40 4	
		Feedthrough	ZL-RTB40 (-1)	
Fuse		ZL-RFU40 4		
D2-08TA	10	Feedthrough	ZL-RTB20 (-1)	ZL-D2-CBL10
F2-08TA				ZL-D2-CBL10-1 ZL-D2-CBL10-2
D2-12TA	19	Feedthrough	ZL-RTB20 (-1)	ZL-D2-CBL19
		Fuse		ZL-RFU20 4
D2-04TRS 2	10	Feedthrough	ZL-RTB20 (-1)	ZL-D2-CBL10
D2-08TR				ZL-D2-CBL10-1 ZL-D2-CBL10-2
F2-08TRS 2				ZL-D2-CBL19 *
F2-08TR 3				ZL-D2-CBL10 *
D2-12TR	19	Feedthrough	ZL-RTB20 (-1)	ZL-D2-CBL19
		Fuse		ZL-RFU20 4

† X in the part number represents a 45° angle plug

* Select the cable length by replacing the * with: Blank = 0.5m, -1 = 1.0m, or -2 = 2.0m.

1 To make a custom cable for the 32-point modules, use: Solder-style 180° connector ZL-D24-CON or Solder-style 45° connector ZL-D24-CON-X

2 Caution: The D2-04TD1, D2-04TRS, and F2-08TRS outputs are derated not to exceed module specs 2A per point and 2A per common when used with the ZIPLink wiring system.

3 The F2-08TR outputs are derated not to exceed 2A per point and 4A per common when used with the ZIPLink wiring system.

4 Fuses (5 x 20mm) are not included. See Edison Electronic Fuse section for (5 x 20mm) fuse. S506 and GMA electronic circuit protection for fast-acting maximum protection. S506 and GMC electronic circuit protection for time-delay performance. Ideal for inductive circuits. To ensure proper operation, do not exceed the voltage and current rating of ZIPLink module. ZL-RFU20 = 2A per circuit; ZL-RFU40 = 400 mA per circuit.



Note: ZIPLink Connector Module specifications follow the Compatibility Matrix tables. ZIPLink Cables specifications are at the end of this ZIPLink section.



Dimensions and Installation

Understanding the installation requirements for your DL205 system will help ensure that the DL205 products operate within their environmental and electrical limits.

Plan for safety

This catalog should never be used as a replacement for the user manual. The user manual, D2-USER-M (downloadable online), contains important safety information that must be followed. The system installation should comply with all appropriate electrical codes and standards.

Environmental specifications

The Environmental Specifications table at the right lists specifications that apply globally to the DL205 system (CPUs, bases, and I/O modules). Be sure that the DL205 system is operated within these environmental specifications.

Base dimensions and mounting

Use the diagrams below to make sure the DL205 system can be installed in your application. To ensure proper airflow for cooling purposes, DL205 bases must be mounted horizontally. It is important to check these dimensions against the conditions required for your application. For example, it is recommended that approximately 3" of space is left in front PLC surface for ease of access and cable clearances. Also, check the installation guidelines for recommended cabinet clearances.

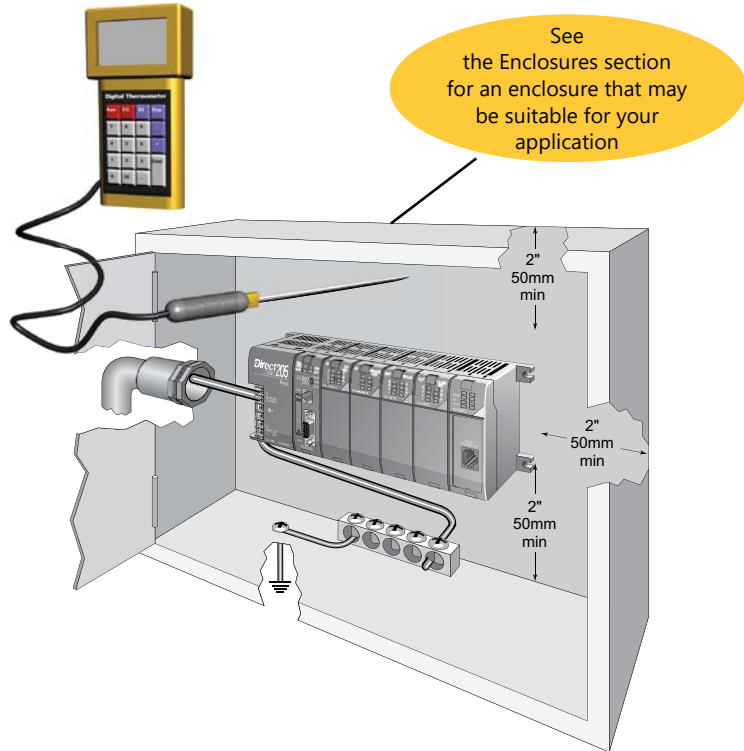

Environmental Specification	Rating
Storage Temperature	-4 to +158 °F (-20 to +70 °C)
Ambient Operating Temperature	32 to 131 °F (0 to 55 °C)
Ambient Humidity	30% to 95% relative humidity (non-condensing)
Vibration Resistance	MIL STD 810C, Method 514.2
Shock Resistance	MIL STD 810C, Method 516.2
Noise Immunity	NEMA (ICS3-304)
Atmosphere	No corrosive gases

Base	A	B	C	D
D2-03B-1, D2-03BDC1-1	6.77" 172mm	6.41" 163mm	5.8" 148mm	7.24" 184mm
D2-04B-1, D2-04BDC1-1	7.99" 203mm	7.63" 194mm	7.04" 179mm	8.46" 215mm
D2-06B-1, D2-06BDC1-1, D2-06BDC2-1	10.43" 265mm	10.07" 256mm	9.48" 241mm	10.90" 277mm
D2-09B-1, D2-09BDC1-1, D2-09BDC2-1	14.09" 358mm	13.74" 349mm	13.14" 334mm	14.56" 370mm

