



# VACT Series AC Voltage Transducers



The VACT series AC voltage transducers are high-performance true RMS transducers for sensing voltage in single-phase installations. Applicable on circuits of 120V, 208V, 240V, 277V, and 480V, the VACT series models provide a fully isolated, 4-20 mA output proportional to rated voltage in both sinusoidal and non-sinusoidal (variable frequency) situations. Housed in a slim, compact, easy-to-install DIN rail mounted enclosure, the VACT series comes in a variety of voltage ranges and use four wire terminal block connections.

## Applications

### True RMS Voltage Monitoring

- Detect below normal or “brown out” voltage conditions; protect against possible motor overheating.
- Identify phase loss conditions by detecting voltage reduction in one or more phase of three-phase motor.
- Monitor over voltage conditions associated with regenerative voltage to help in diagnosing/avoiding motor drive issues.
- Detect voltage conditions which may cause stress in or damage to soft starter components (SCRs).

## Features

- **True RMS Output:** Allows for use in situations where power supplied is non-sinusoidal, poor power quality installations or other electrically harsh/challenging environments.
- **Standard 4-20 mA Loop Powered Output:** Industry standard output makes use with existing controllers, data loggers and SCADA equipment easy and reliable.
- **Input/Output Isolation:** Input and output circuitry electrically isolated for improved safety of use.
- **Compact DIN rail Mount Enclosure:** Space saving 35mm wide enclosure makes installation quick and easy.

## Agency Approvals



VACT Series AC Voltage Transducers				
Part Number	Description	Pcs/Pkg	Wt (lb)	Price
VACT150-42L	Single-phase AC voltage transducer, 0-150 VAC input range, 4-20 mA output (sinking)	1	0.25	\$135.00
VACT500-42L	Single-phase AC voltage transducer, 0-500 VAC input range, 4-20 mA output (sinking)	1	0.25	\$135.00

VACT Series Specifications	
<b>Power Supply</b>	24VDC (22VDC-40VDC), Use Class 2 power supply only
<b>Voltage Measurement</b>	150V (for monitoring 120VAC) and 500V (for monitoring 208, 240, 277, 480 VAC), not to exceed 600VDC
<b>Output</b>	4-20 mA proportional; loop powered (sinking), capped at 24mA max
<b>Response Time</b>	250ms (to 90% value)
<b>Accuracy</b>	<1%
<b>Linearity</b>	<0.5%
<b>Output Loading</b>	500Ω maximum
<b>Isolation Voltage</b>	2500 Volts per UL
<b>Frequency Range</b>	40-100 Hz
<b>Case</b>	UL94V-0 Flammability Rating
<b>Environmental</b>	Operating temperature: -4 to 122°F (-20 to 50°C)
	Relative humidity: 0-95% RH, Non-condensing
	Pollution Degree 2
	Altitude to 2000 meters
<b>Agency Approvals*</b>	UL/cUL (E222847), CE

\* To obtain the most current agency approval information, see the Agency Approval Checklist section on the specific part number's web page at [www.AutomationDirect.com](http://www.AutomationDirect.com)



# VACT Series AC Voltage Transducers

## Connection

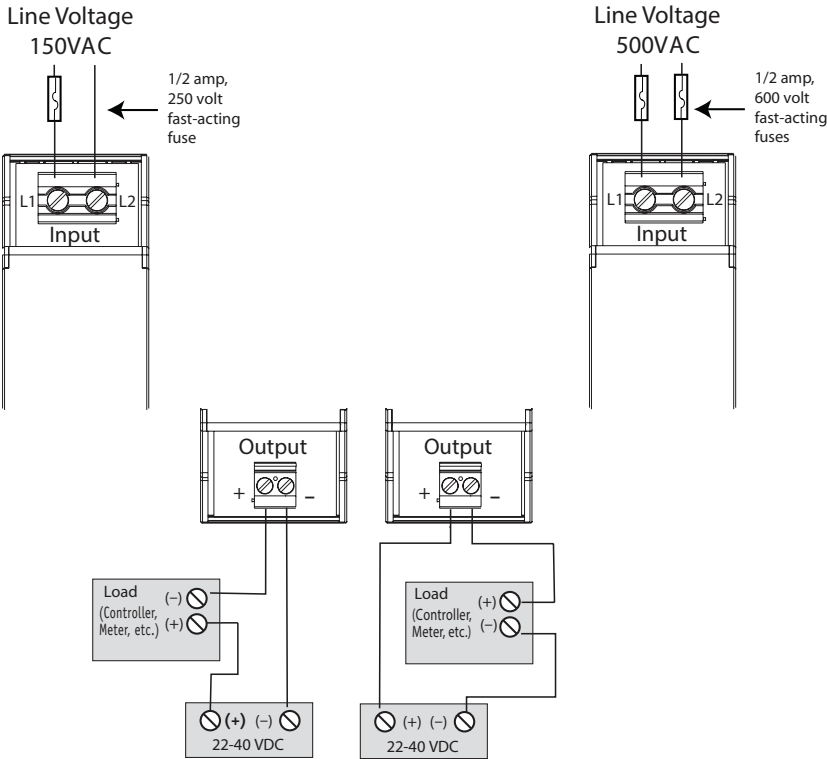

## Dimensions

Inches [mm]

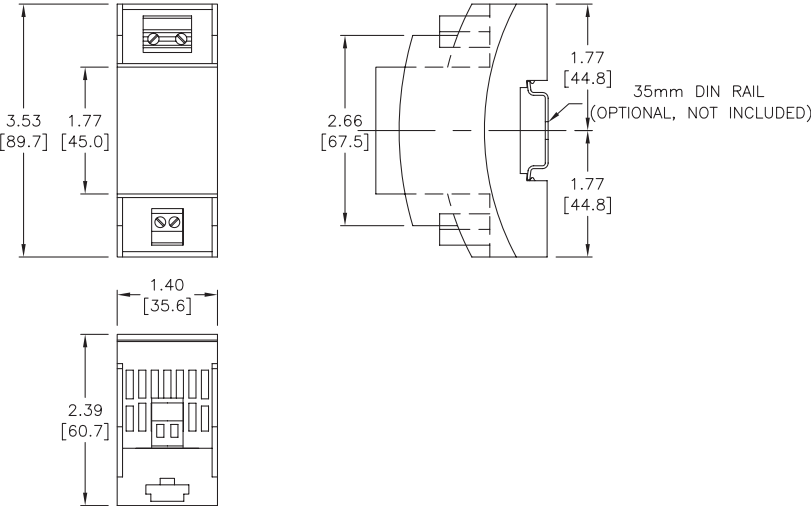

### VACT Series

See our website [www.AutomationDirect.com](http://www.AutomationDirect.com) for complete Engineering drawings.