

Group Motor Protection

Group motor protection provides numerous benefits. It's economical because one protection device handles multiple motors.

Learn how to satisfy the NEC requirements for group motor installations.

By Brent Purdy,
Product Manager, Power & Circuit Protection, AutomationDirect



The usual way of preventing a small motor from drawing too much current is to install overcurrent protection in the form of a circuit breaker or some other kind of limiter. But installations that employ more than one motor might not want to use this approach. Dedicating one overcurrent device for every motor can drive up costs and take up a lot of space on the control panel.

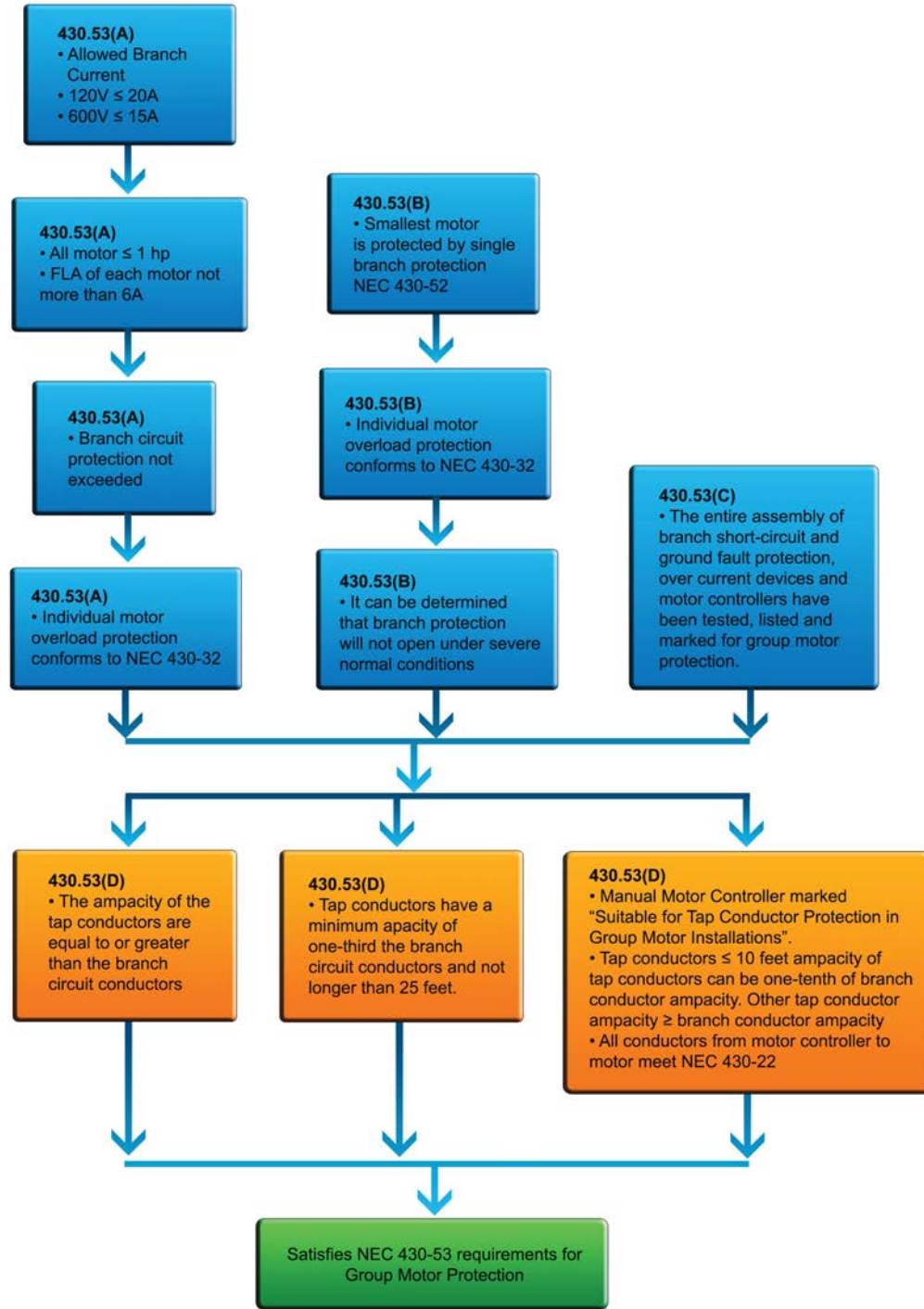

Figure 1: Figure 430-1 of the NEC provides a graphical representation of how to apply Article 430.

There's a better way of protecting multiple motors: Use group motor protection as described in NFPA 70, the U.S. National Electrical Code (NEC) Article 430.53. This lets two or more motors be protected by the same overcurrent device as long as the installation meets specific requirements. The big advantage of this technique is that the upstream fuse or circuit breaker can be rated for a current high enough to prevent nuisance tripping, while reducing cost and panel device count. Meanwhile, a motor starter protects each individual motor circuit from overloads. Most installations use IEC-rated manual motor starters because they comply with NFPA 70 at a reasonable cost.

In the context of group protection, it is important to distinguish between overcurrent and overload protection. Overcurrent devices such as fuses and circuit breakers protect against short circuits, events that typically generate significant amounts of excess current in sub-millisecond timeframes. In contrast, overload devices protect against abnormally high motor loads, events that typically generate much smaller amounts of excess current over a more extended time period.

Benefits of Group Motor Protection
• Lower cost
• Fewer components
• Occupies less panel space
• Fewer wires
• Allows use of smaller wiring
• Simpler to troubleshoot

Group motor protection provides numerous benefits. It's economical because one protection device handles multiple motors. It typically ties up half the panel space of individual protection devices or even less. Troubleshooting is less tedious because there are fewer components and wiring connections to check when problems arise. And users needn't stock as many spare parts.

But the technique requires some upfront engineering. So it works best for installations that will be duplicated, as with OEM machines, robots, or other engineered products deployed in multiple locations. Traditional overcurrent protection may be a better solution for one-off projects involving only a few motors. In a nutshell, the more motors used, the more this technique saves; savings are minimal for installations with just two motors.

NEC for groups of motors

The NEC standard provides guidelines on the safe installation of electrical wiring and powered equipment. The NEC is not law, but it does form the basis for many state and

local laws. The size of the NEC is intimidating, spanning over 1,000 pages, and it requires serious study. Readers should keep in mind that here, we can only provide an overview. Article 430 of the NEC details motor branch circuit requirements for short circuit and ground fault protection, as well as motor overload protection. The article requires protection for all components in the circuit (motors, terminals, conductors, etc.) to minimize the risk of fire and explosions. NEC section 430.53 covers group motor installation.

Article 430.53 specifies the requirements for protecting multiple motors on a single branch circuit. It is divided into four sections, sometimes referred to as 430.53(A), 430.53(B), etc. For simplicity, we'll refer to these as Sections A, B, C and D.

In all sections of Article 430, the NEC uses two similar but not identical terms when discussing motor current: FLA (Full Load Amps) and FLC (Full Load Current). FLA is the motor's full-load amperage at rated load and voltage. This number is stamped on the nameplate and should be used for sizing overload protection for the motor.

But Article 430.6(A) (1) dictates FLC be used for most calculations that size conductors or overcurrent protective devices. (Note there are a few exceptions for non-standard applications.) Of course, there are a variety of motor types and designs available. Consequently, the NEC created tables [430.247 through 430.250] of FLC values large enough to represent worst-case scenarios.

Article 430.53 demonstrates three paths to protect multiple motors in a single installation: Section A, Section B or Section C. All installations must meet the requirements in one of these sections, and each installation must adhere to the requirements of Section D which covers conductor sizing.

Section A covers groupings of small motors with small loads. Section A only applies when all motors are rated 1 hp or less. In addition, the branch circuit in question must be a nominal 120V protected at more than 20A, or a nominal 600V (or less) protected at no more than 15A, and the following must be true: The FLC of each motor is below 6A; the rating of the branch circuit or of the short circuit and ground fault protection device marked on any of the controllers; and each motor has individual overload protection that conforms to NEC 430.32.

Section B is another option for motor group protection. This section encompasses motors of different sizes, but it sizes protection for the motor with the smallest rating in the group, thus limiting its use. Sizing for the motor with the smallest rating may initially seem counterintuitive. However, readers should remember that NEC 430.53 is about protecting the circuit. If the group protection is sized for the largest motor, the smaller motors can easily short, causing serious damage.

Also for Section B, the protective devices selected for the smallest motor must safeguard any other larger motors without nuisance tripping, especially during startup or when a motor jams. Ideally, the branch device won't trip on a jam or a startup but activates only on a fault.

Installations that comply with section B must meet all the following conditions: The fuse or circuit breaker protecting the motors must be sized for the smallest one in the branch circuit, using Table 430.52; The branch circuit, short-circuit and ground fault protection device won't open under the most severe normal conditions, implying all loads can start simultaneously without opening the branch overcurrent device; and each motor has individual overload protection that conforms to NEC 430.32.

Section C covers multiple motors with listed components. It is the section most installations follow because it is flexible as to the number of motors and their sizes. Section C demands that all branch short-circuit and ground fault protection devices, overcurrent devices and motor controllers be UL tested, listed, and marked for group motor protection. That includes motor overload devices and controllers with a fuse or inverse-time circuit breaker, or both. The entire assembly doesn't comply if one component isn't listed.

INSTALLATION SCHEMATIC

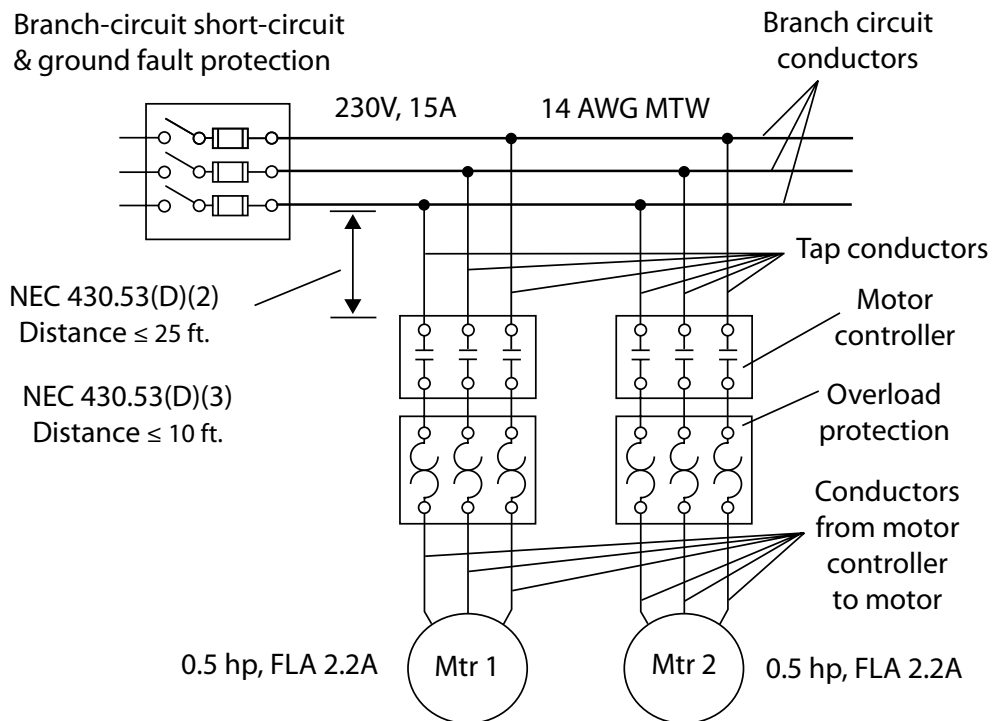

Figure 2: A group motor installation in compliance with Section A.

In addition, each motor must have individual overload protection that conforms to NEC 430.32. Moreover, fuses or an inverse-time circuit breaker must protect the whole branch, and the ratings for these devices must not exceed the sum of two factors: A rating specified in Table 430.52 for the largest motor, plus the sum of full-load currents drawn by the rest of the motors and loads in the branch. There are special considerations for overcurrent protective devices of less than 800A : If users calculate

a rating that is less than the ampacity of the supply conductors, they select the next higher standard size but not beyond that allowed by NEC 240.4B.

The most practical way to meet these requirements is to use a manual motor starter (MMS) in conjunction with a contactor for each motor. Typical single motor circuits (not using group protection) employ a fuse or circuit breaker with a contactor and an overload unit. Use of an MMS and associated contactor eliminates the extra overload device. Installations need only one device per group instead of one per motor.

For an example of where Section C might be used, consider an OEM designing a control panel for a conveyor system. The conveyor system will have several branch circuits and each branch circuit controls four conveyors. Specifically, each branch will feed three 1.5 hp and one 3 hp conveyor motors, all operating at 480 VAC three-phase with a 1.15 service factor.

A 20A Class CC fuse protects the four conveyor motor branch circuits, and each branch circuit contains a listed MMS with a contactor to form a starter, with 18 AWG wire connecting each starter to each motor. NEC 430.53(C) dictates the following parameters:

From Table 430.250, the FLC of the motors is 4.8A (3 hp) and 3.0 A (1.5 hp). Branch circuit protection is a 20A fuse per 430.53(C)(4), which requires 12 AWG MTW conductors. Per 430.53(D), the tap conductors may be 16 AWG rated at 10A if they are less than 25 ft. long. The MMS overload rating is 125% of FLA, which is 6A for the 3 hp motor and 3.75A for the 1.5 hp motor, per 430.32(1). The conductors to the motor from the MMS (125% of FLC) are 18 AWG per [430.22] [240.4(E)(6)].

The installation meets section C requirements because the main branch conductors are 12 AWG MTW wire, which is rated for 20A [310.16]. Tap conductors are 16 AWG MTW rated 10A [240.4(E)(6)]. The last item to verify for section C is the size of the conductor running from the controller to the motor. NEC 430.22 requires the conductors have an ampacity of at least 125% of the motor FLC. In this example the conductor is $(4.8 \times 125\%) = 6A$. The 18 AWG MTW wire is rated for 7A (240.4(D)(1)), so the installation complies.

Each motor starter is listed for group installation, and the installation doesn't exceed the maximum fuse or circuit breaker size of 500A designated by the manufacturer. Each MMS complies with 430.40 for the smallest motor. The branch circuit breaker is less than the calculation 300% (defined by 430.52) times the FLC of the largest motor plus the sum of the other motor FLC's $(300\% \times 4.8 + (3 \times 3.0)) = 23.4 > 20A$ fuse. And all loads are motors, so 430.53(C)(6) does not apply.

It is important to note that 16 and 18 AWG wire can only be used for power circuits under specific criteria, with the key criteria being the use of a current limiting fuse such as a class CC [240.4(D)].

Section D covers conductor sizing for group motor installations. Designers have a choice among sections A, B, and C when selecting motor group protection, but Section D, on the other hand, is mandatory for all installations. Section D requires that all conductors from the controller to the motor meet NEC Article 430.22 standards by being sized to at least 125% of the smallest motor's FLC. In addition, the requirements of NEC Article 430.32 (individual overload protection per motor) also apply for all branch circuits, regardless how many motors they feed. Finally, as with all tap conductors, the conductors must be protected from physical damage by enclosures, conduits or similar means.

Section D also dictates that only one of the following three requirements be met: The ampacity of the tap conductors are equal to or greater than the ampacity of the branch circuit conductors; The tap conductors have a minimum ampacity of one-third that of the branch circuit conductors and are no longer than 25 ft.; Or a manual motor controller may be used if it is marked "Suitable for Tap Conductor Protection in Group Motor Installations." In this case, the following must apply: Tap conductors supplying the controller that are less than 10 ft. long must have at least one-tenth the ampacity of the branch circuit device setting. Tap conductors longer than 10 ft. must have an ampacity equal to or greater than the branch ampacity.

For example, suppose an OEM is designing a new packaging machine for a manufacturing process. Two motors will control a conveying operation and a cutting operation. Both are 1 hp, 230V three-phase squirrel cage motors with 1.0 service factors. The designer begins by using NEC Article 430.53 to determine which section (A, B or C) applies. In this case the designs will satisfy all the requirements of section A. From 430.52 and 310.16, the branch circuit is a 15A Class CC fuse feeding 14 AWG MTW wire because: All motors are rated 1 hp or less; The FLC of each motor does not exceed 6A (table 430.250 dictates 4.2A); The installation doesn't exceed the ratings of the branch-circuit, short-circuit and ground fault protection device; and individual motor overload protection is set at 115% (4.8A) per NEC 430.32(B)(1).

Now the designer must determine if the machine meets the requirements of section D. The motor group protection requirements are that: The branch circuit is protected with a Class CC fuse rated at 15A [430.52]; The main branch conductors are 14 AWG MTW wire, which is rated for 15A [240.4(D)(3)]; The tap conductors are 18 AWG MTW wire, which meet conditions in Section D(2) as described above are rated at 7A [240.4(E)(6)]. The last item to verify is the size of the conductor running from the controller to the motor. Section 430.22 requires that conductors have an ampacity of at least 125% of the motor FLC. In this example the conductor is $(4.2 \times 125\%) = 5.25A$. The 18 AWG MTW wire is rated for 7A [240.4(D)(1)], so the installation complies.

All in all, group motor protection requires more design effort up front, but the benefits often more than compensate for the extra work, particularly for installations that are duplicated repeatedly. Such cases can amortize the design costs over many installations and bring many benefits.

About AutomationDirect

In business since 1994, AutomationDirect is a distributor offering thousands of industrial automation products for electrical control systems, including PLCs, operator interfaces, AC drives, motors, stepper systems, sensors, motor control, enclosures and more. Their prices are typically well below the list price of more traditional automation companies because of their model and focus on efficiency and the majority of their products are stocked for same-day shipping. Plus, get free two-day delivery on orders over \$49; some limitations apply. For more information, contact them at 800-633-0405 or visit www.AutomationDirect.com/Circuit-Protection
www.AutomationDirect.com/Motor-Controls

Save on Group Motor Protection from AutomationDirect.com



Get UL 489 Rated MCCBs at savings of up to 50%.

[▶ Shop Now](#)

www.AutomationDirect.com/Circuit-Protection

Save up to 50% on Group Motor Protection
www.AutomationDirect.com/Circuit-Protection
www.AutomationDirect.com/Motor-Controls