

Assembly and Operating Instructions

- 1.) Strip cable jacket 2"
- 2.) Strip conductors 0.2"
- 3.) Pass cable through Cable Gland. If cable is too big to fit through cable gland, remove inner grommet within cable gland and use only outer grommet. (See acceptable diameters below)
- 4.) Insert wires into Terminal Blocks by pushing button and inserting stripped wire, then release button. Wire according to schematic on back of main block.
- 5.) Assemble backshell to main housing by tightening the M3 screws (20 lbf-in [2.3Nm])
- 6.) Tighten Cable Gland dome nut (24 lbf-in [2.7Nm])

Note: Not for current interrupting

Wiring

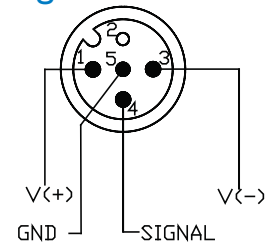

Cable Sizes and Types

Cable must be USR/CNR R/C AWM or USR R/C AWM CSA Certified

- PUR (20233) & PVC (2661, 2517, 2587, 21098): 18/3, 22/4 combination AWG cable.
- SJE, SJT, SE, ST 18AWG (Cord must be UL/cUL Listed or UL Listed and CSA Certified)

All cables must have stranded copper conductors and are suitable for use with the minimum and maximum cable diameters per cable jacket material type indicated below.

Cable Diameters

With inner grommet intact
(max OD 7.9mm):

- PUR - 0.19" [4.8 mm] min.
- PVC - 0.17" [4.3mm] min.

With inner grommet removed
(max OD 12.5 mm):

- PUR - 0.28" [7.2 mm] min.
- PVC - 0.28" [7.2 mm] min.
- SJT/SJE/ST/SE - 0.305" [7.75 mm] min.

Volts / Amps

150 VAC/DC max / 8A for entire block,
3A max. for any one port. Voltage cannot exceed
the voltage rating of the cable being used.

Pin Out Table	
ZP-JBH44-00-FW	
Port 1-4 Pin 1	J1 / V+
Port 1-4 Pin 3	J1 / V-
Port 1-4 Pin 5	J1 / Ground
Port 1 Pin 2	Not used
Port 1 Pin 4	J2 / 1
Port 2 Pin 2	Not used
Port 2 Pin 4	J2 / 2
Port 3 Pin 2	Not used
Port 3 Pin 4	J2 / 3
Port 4 Pin 2	Not used
Port 4 Pin 4	J2 / 4

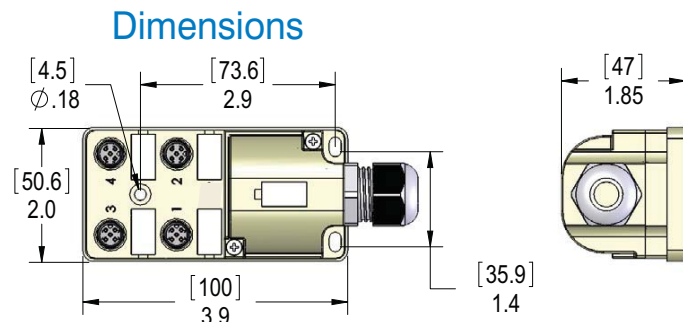

Dimensions in inches [millimeters]