

WARNING: We recommend installing up to a 0.5 Amp fast-blow fuse such as AGC-5 or similar in series with the power supply as an extra safety measure.

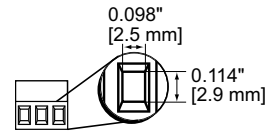

Terminal Block Insertion Point Opening Dimension

ZL-RRL16W-24-1 Sinking				
DirectLOGIC	Productivity3000	CLICK	Productivity2000	BRX
J1 J2 J3	J1 J2 J3	J1 J2 J3	J1 J2 J3	J1 J2 J3

ZL-RRL16W-24-2 Sourcing				
DirectLOGIC	Productivity3000	CLICK	Productivity2000	BRX
J1 J2 J3	J1 J2 J3	J1 J2 J3	J1 J2 J3	J1 J2 J3

Jumper Position	Description
J1 +24V	Connects +24VDC to Connector Pins 1,7,13, & 19
J1 GND	Connects GND to Connector Pins 1,7,13, & 19
J2 +24V	Connects +24VDC to Connector Pins 2, 8,14, & 20
J2 GND	Connects GND to Connector Pins 2, 8,14, & 20
J3 +24V	Factory set On ZL-RRL16W-24-1 Connects +24VDC to Relay Coil Commons
J3 GND	Factory set On ZL-RRL16W-24-2 Connects GND to Relay Coil Common

ZL-RRL16W-24 Pinouts	
Connector Pin	Relay
3	Relay 1 (TB1)
4	Relay 2 (TB2)
5	Relay 3 (TB3)
6	Relay 4 (TB4)
9	Relay 9 (TB9)
10	Relay 10 (TB10)
11	Relay 11 (TB11)
12	Relay 12 (TB12)
15	Relay 5 (TB5)
16	Relay 6 (TB6)
17	Relay 7 (TB7)
18	Relay 8 (TB8)
21	Relay 13 (TB13)
22	Relay 14 (TB14)
23	Relay 15 (TB15)
24	Relay 16 (TB16)

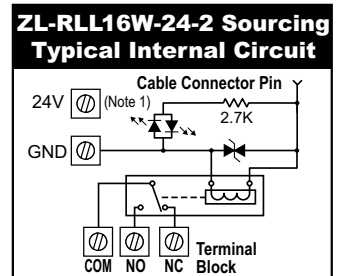
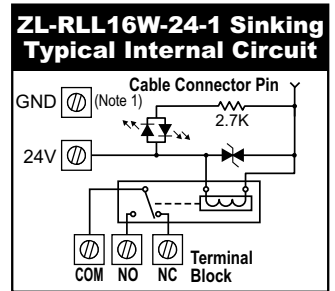

Note 1: See Jumper Notes.

General Module Specifications		Relay Contact Specifications	
Description	16 Output Relay module with LEDs, 24 VDC coil	Current Rating	30VDC @ 10A General Use 250VAC @ 8A General Use
Operating Frequency	20 cycles per minute electrical 300 cycles per minute mechanical	Contact Type	1 Form C (SPDT)
Isolation Coil to Contact	2500VAC for 1 minute	Contact Voltage (per point)*	250VAC/30VDC
Isolation NC Contact to NO Contact Same Relay	1000VAC for 1 minute	Maximum Power Inductive	2000VA General Use
Isolation Between Relays	1000VAC for 1 minute	Maximum Power Resistive	AC 2000VA, DC 300W
Red LED Indicator State Relay	ON = relay energized, OFF = relay de-energized	Maximum Switching Voltage	250VAC, 110VDC
Operating Temperature Range	32 to 140°F (0 to 60°C)	Minimum Load	10mA @ 5VDC
Terminal Block Contacts	Copper alloy, tin-lead plated	Contact Resistance	100mΩ Max @ 1A, 6VDC
Wire Range*	12–24 AWG Solid or Stranded Conductor	Contact Material	AgNi (Silver Nickel Alloy)
Wire Strip Length	0.24–0.27 in (6–7mm)	Coil Specifications	
Screw Torque	4.4 in-lbs (0.5 Nm)	Input Voltage Rating**	24VDC (-20 / +30%)
Replacement Relay	ZL-RELAY-24X4	Maximum Continuous Coil Voltage	31.2 VDC
Connector Type	Molex Micro-Fit 3.0, 24 pin connector, example receptacle 43020-2400, Pins 43031 Series, Male	Rated Current Per Coil	16.7 mA (±10%) @ 24VDC
Cable/Wire Clearance	0.5 in (12.7 mm)	Coil Resistance	1440Ω (±10%)
Mounting Restriction	None	Power Consumption Per Coil	0.4 W
Weight	610g (21.5 oz)	Total Coil Supply Current Max.	293mA (All relays on)
Approvals	File # E157382 UL, cUL 508, CE, EN 61131-2:2007	Pick Up Current Max. Per Coil	15mA
		Drop-Out Voltage Min.	1.2 VDC
		Pick-Up Voltage Max.	19.2 VDC
		Off to On/On to Off Response Time	12ms/8ms

*Use conductors rated 60°/75°C for relay outputs.

**Relay modules are reverse polarity protected and will not operate if reverse voltage is connected.

Remove or Install Relay

- 1 Rotate retaining clip away from relay.

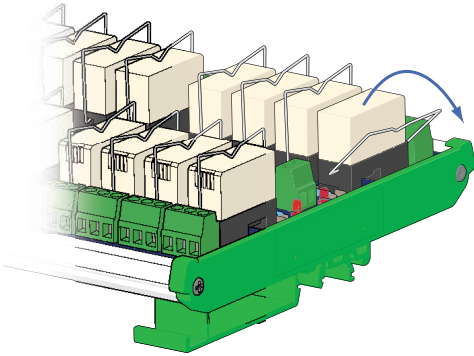

- 2 Remove relay from module.

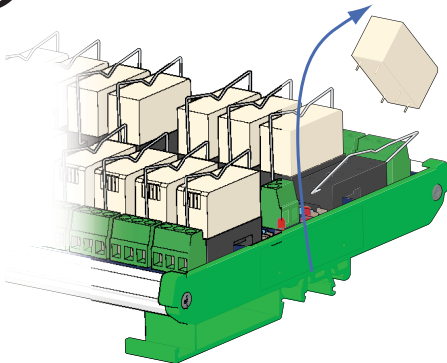

Reverse procedure to replace relay.

DIN Rail Installation and Removal

To install ZIPLink module, insert upper tab into DIN rail.

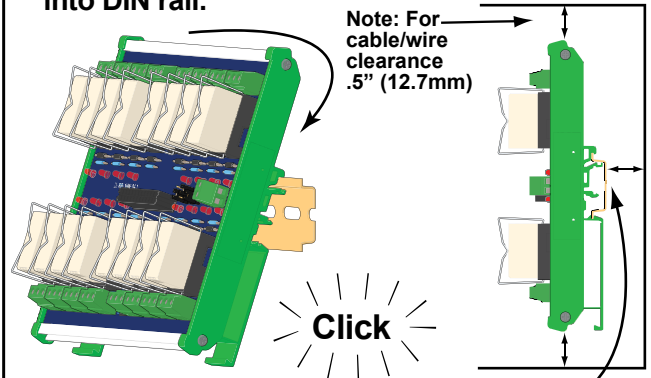

Rotate until firmly seated

and locked on DIN rail

To remove ZIPLink module, insert screwdriver between Tab 1 and module.

Pry up to release clip from DIN rail.

Repeat for Tab 2.

ZIPLink Cable Removal

- 2 Pull connector from socket.

- 1 Push tab on raised tip and hold.

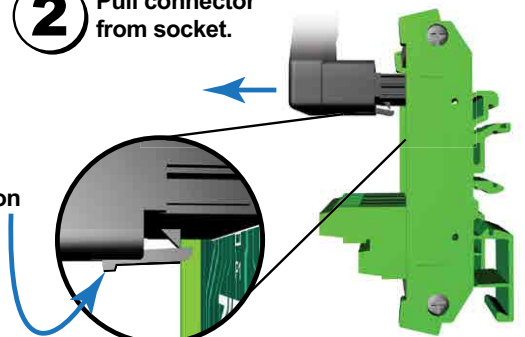

For Replacement Relay
 Use ZL-RELAY-24X4, Qty. 4/pkg.

WARNING: To minimize the risk of potential safety problems, you should follow all applicable local and national codes that regulate the installation and operation of your equipment. These codes vary from area to area and it is your responsibility to determine which codes should be followed, and to verify that the equipment, installation, and operation are in compliance with the latest revision of these codes.

Equipment damage or serious injury to personnel can result from the failure to follow all applicable codes and standards. We do not guarantee the products described in this publication are suitable for your particular application, nor do we assume any responsibility for your product design, installation, or operation.

If you have any questions concerning the installation or operation of this equipment, or if you need additional information, please call Technical Support at 770-844-4200.

This publication is based on information that was available at the time it was printed. At AutomationDirect.com® we constantly strive to improve our products and services, so we reserve the right to make changes to the products and/or publications at any time without notice and without any obligation. This publication may also discuss features that may not be available in certain revisions of the product.

Part Number	Revision	Date
ZL-RRL16W-24	3rd Ed.	12/6/2017