



## LED Connector Module ZL-CM16L120 Cables and PLC I/O Modules

PLC Type	Cable Type	PLC I/O Module Type	Connector Module Type
DL205	ZL-2CBL2L	D2-16NA	ZL-CM16L120
DL305	ZL-3CBL2L	D3-16NA	ZL-CM16L120
DL405	ZL-4CBL2	D4-16NA	ZL-CM16L120

**WARNING : WIRE ONLY ACCORDING TO WIRING DIAGRAMS SHOWN BELOW TO AVOID CAUSING DAMAGE TO THE PLC OR CONNECTOR MODULE. MATCH THE CORRECT COMBINATION OF CABLE, PLC I/O MODULE, AND CONNECTOR MODULE AS SHOWN.**

### EXAMPLE CONNECT

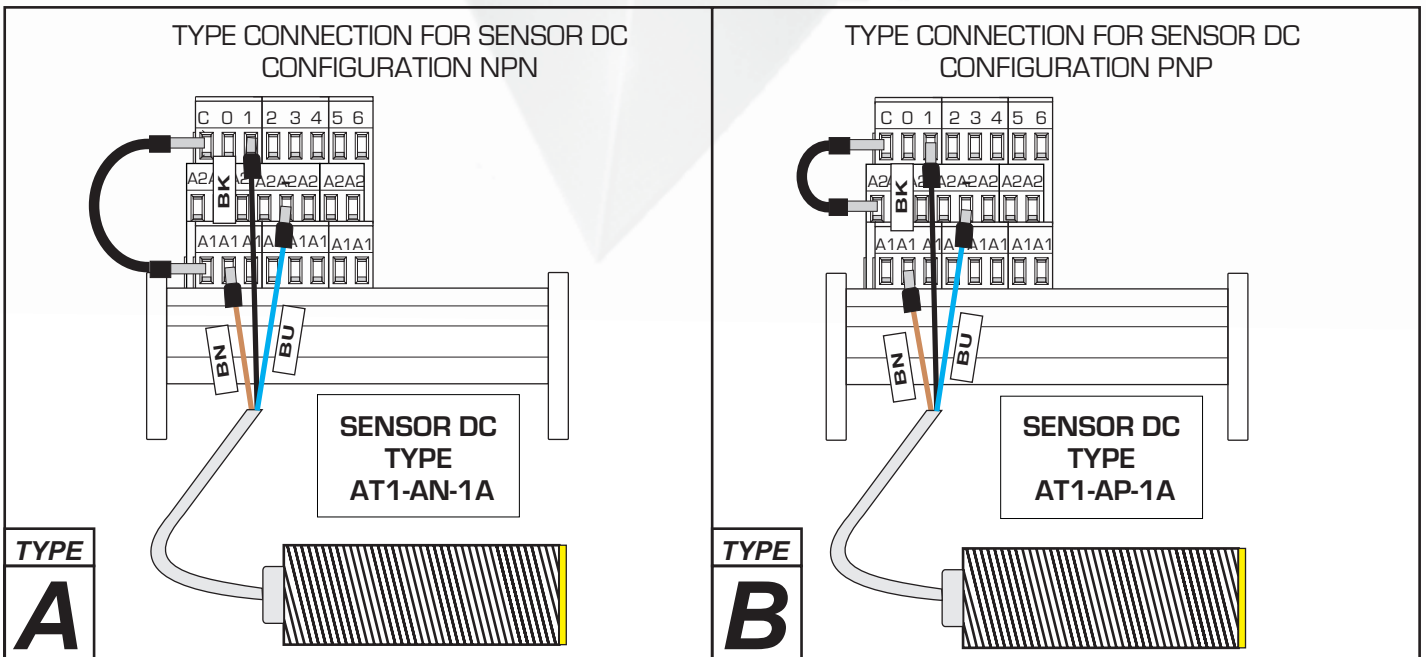

TYPE CONNECTION FOR SWITCH DC WITH A2 COMMON

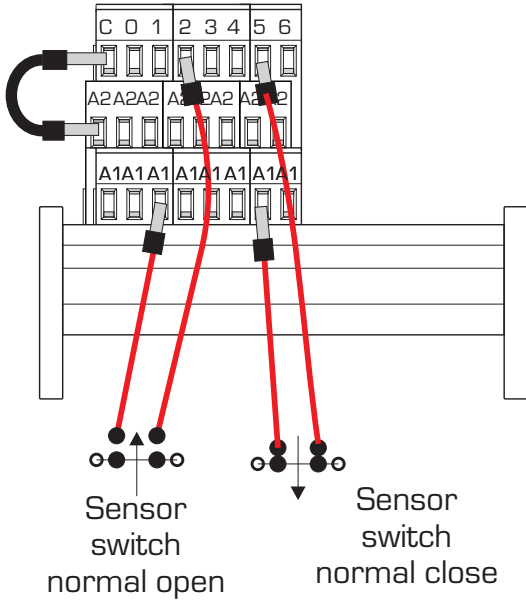

TYPE

**C**

Sensor switch normal open      Sensor switch normal close

TYPE CONNECTION FOR SWITCH DC WITH A1 COMMON

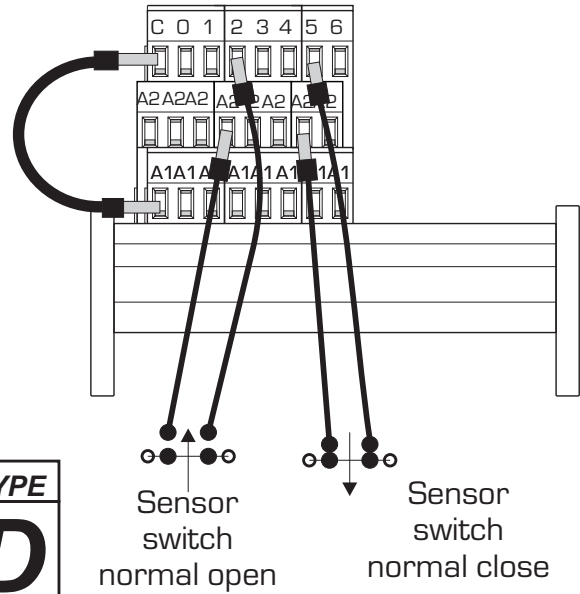

TYPE

**D**

Sensor switch normal open      Sensor switch normal close

TYPE CONNECTION FOR SENSOR AC WITH A1 COMMON

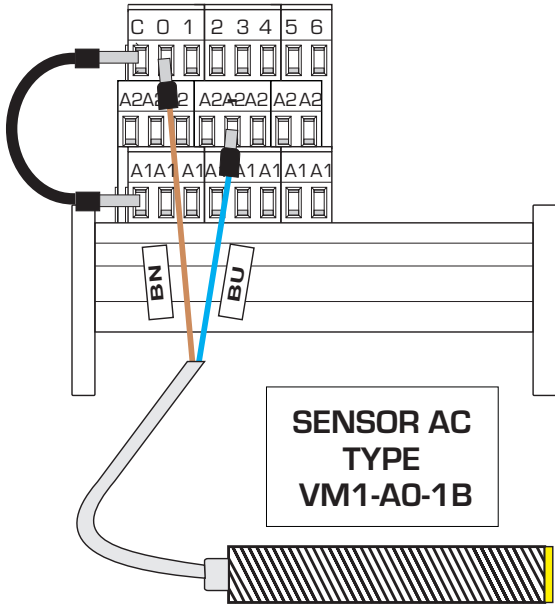

TYPE

**E**

SENSOR AC TYPE VM1-A0-1B

TYPE CONNECTION FOR SENSOR AC WITH A2 COMMON

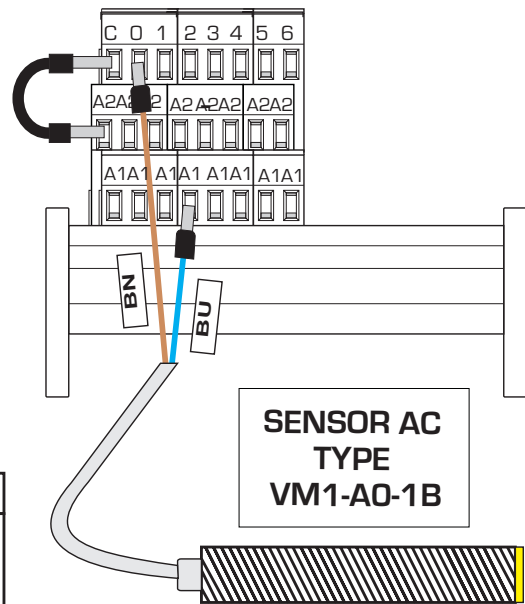

TYPE

**F**

SENSOR AC TYPE VM1-A0-1B

TYPE CONNECTION FOR SWITCH AC WITH A2 COMMON

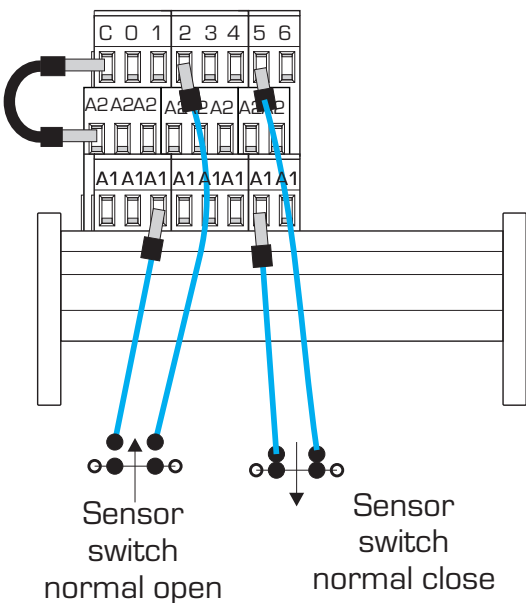

TYPE

**G**

Sensor switch normal open      Sensor switch normal close

TYPE CONNECTION FOR SWITCH AC WITH A1 COMMON

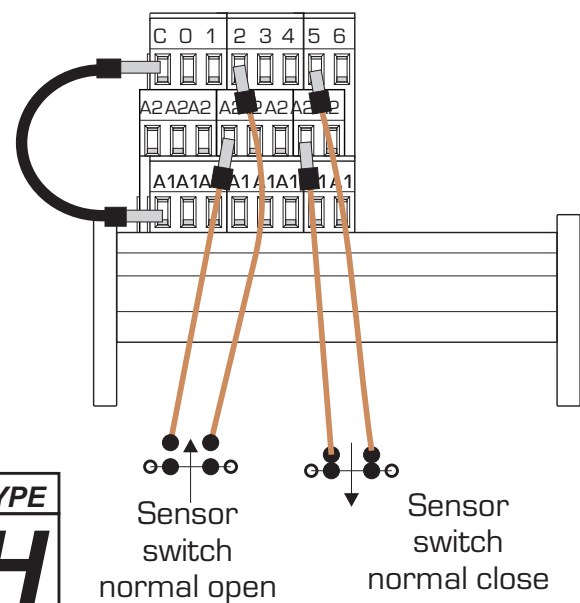

TYPE

**H**

Sensor switch normal open      Sensor switch normal close

# Wiring Diagram power supply and cable

PLC DL 205 Type D2-16NA  
AC Input I/O Module

Cable ZL-2CBL2L

**Warning :**  
It is recommended to install a 2 Amp fast blow fuse in series with the power supply as an extra safety measure.  
Use a fuse terminal block such as a DINnector DN-F10 or DN-F10L

ZL-CM16L120

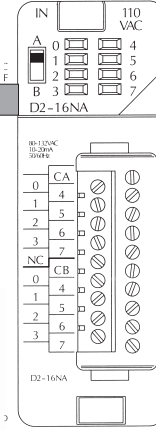
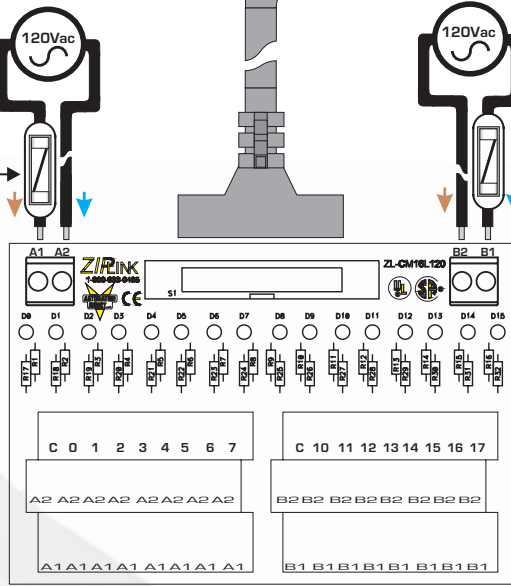

- I/O Module Input Octal Address 0 corresponds to LED 0
- I/O Module Input Octal Address 1 corresponds to LED 1
- I/O Module Input Octal Address 2 corresponds to LED 2
- I/O Module Input Octal Address 3 corresponds to LED 3
- I/O Module Input Octal Address 4 corresponds to LED 4
- I/O Module Input Octal Address 5 corresponds to LED 5
- I/O Module Input Octal Address 6 corresponds to LED 6
- I/O Module Input Octal Address 7 corresponds to LED 7
- I/O Module Input Octal Address 10 corresponds to LED 8
- I/O Module Input Octal Address 11 corresponds to LED 9
- I/O Module Input Octal Address 12 corresponds to LED 10
- I/O Module Input Octal Address 13 corresponds to LED 11
- I/O Module Input Octal Address 14 corresponds to LED 12
- I/O Module Input Octal Address 15 corresponds to LED 13
- I/O Module Input Octal Address 16 corresponds to LED 14
- I/O Module Input Octal Address 17 corresponds to LED 15

COMPATIBLE WITH CONNECTION:

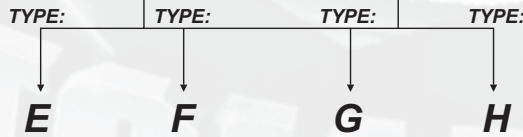

# Wiring Diagram power supply and cable

PLC DL 305 Type D3-16NA  
AC Input I/O Module

Cable ZL-3CBL2L

**Warning :**  
It is recommended to install a 2 Amp fast blow fuse in series with the power supply as an extra safety measure.  
Use a fuse terminal block such as a DINnector DN-F10 or DN-F10L

ZL-CM16L120

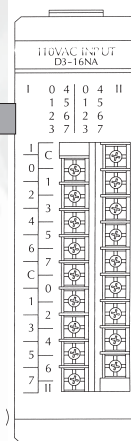
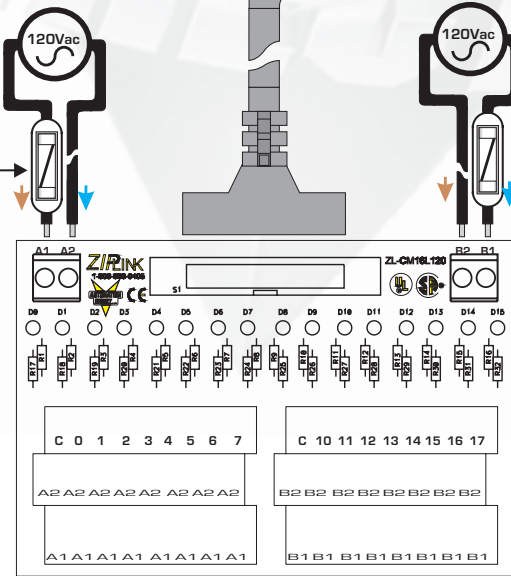

- I/O Module Input Octal Address 0 corresponds to LED 0
- I/O Module Input Octal Address 1 corresponds to LED 1
- I/O Module Input Octal Address 2 corresponds to LED 2
- I/O Module Input Octal Address 3 corresponds to LED 3
- I/O Module Input Octal Address 4 corresponds to LED 4
- I/O Module Input Octal Address 5 corresponds to LED 5
- I/O Module Input Octal Address 6 corresponds to LED 6
- I/O Module Input Octal Address 7 corresponds to LED 7
- I/O Module Input Octal Address 10 corresponds to LED 8
- I/O Module Input Octal Address 11 corresponds to LED 9
- I/O Module Input Octal Address 12 corresponds to LED 10
- I/O Module Input Octal Address 13 corresponds to LED 11
- I/O Module Input Octal Address 14 corresponds to LED 12
- I/O Module Input Octal Address 15 corresponds to LED 13
- I/O Module Input Octal Address 16 corresponds to LED 14
- I/O Module Input Octal Address 17 corresponds to LED 15

COMPATIBLE WITH CONNECTION:

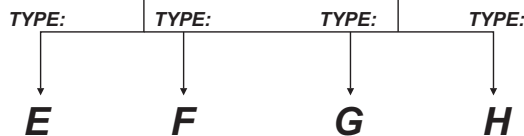

# Wiring Diagram power supply and cable

PLC DL 405 Type D4-16NA  
AC Input I/O Module

Cable ZL-4CBL2

**Warning :**  
It is recommended to install a 2 Amp fast blow fuse in series with the power supply as an extra safety measure.  
Use a fuse terminal block such as a DINnector DN-F10 or DN-F10L

ZL-CM16L120

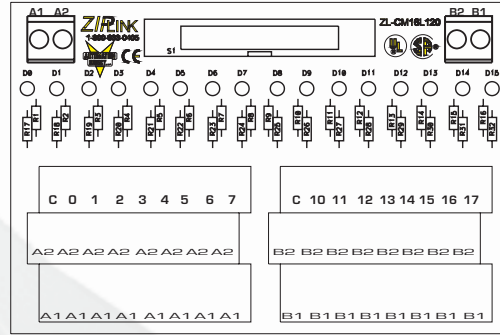

COMPATIBLE WITH CONNECTION:

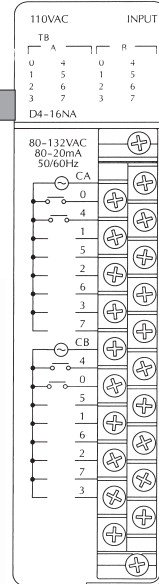
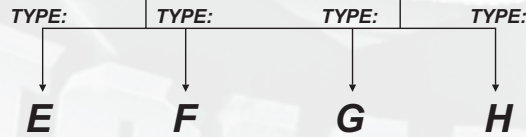

- I/O Module Input Octal Address 0 corresponds to LED 0
- I/O Module Input Octal Address 1 corresponds to LED 1
- I/O Module Input Octal Address 2 corresponds to LED 2
- I/O Module Input Octal Address 3 corresponds to LED 3
- I/O Module Input Octal Address 4 corresponds to LED 4
- I/O Module Input Octal Address 5 corresponds to LED 5
- I/O Module Input Octal Address 6 corresponds to LED 6
- I/O Module Input Octal Address 7 corresponds to LED 7
- I/O Module Input Octal Address 10 corresponds to LED 8
- I/O Module Input Octal Address 11 corresponds to LED 9
- I/O Module Input Octal Address 12 corresponds to LED 10
- I/O Module Input Octal Address 13 corresponds to LED 11
- I/O Module Input Octal Address 14 corresponds to LED 12
- I/O Module Input Octal Address 15 corresponds to LED 13
- I/O Module Input Octal Address 16 corresponds to LED 14
- I/O Module Input Octal Address 17 corresponds to LED 15