



To download fullsize color .pdf Ziplink Wiring Diagrams go to www.Automationdirect.com website

ZIP LINK™
Automationdirect.com
800-633-0405

Communication Connector Module DN-15TB Cables and PLC Modules

PLC Type	Cable Type	PLC Module Type	Connector Module Type
DL205	ZL-DN15TB-CBL	DL-250CPU	DN-15TB

Application Note: DN-15TB for use in end-of-run wiring applications (point-to-point) only. Not for use in middle station applications, such as in a multi-drop network.

WARNING : WIRE ONLY ACCORDING TO WIRING DIAGRAMS SHOWN BELOW TO AVOID CAUSING DAMAGE TO THE PLC OR CONNECTOR MODULE. MATCH THE CORRECT COMBINATION OF CABLE, PLC I/O MODULE, AND CONNECTOR MODULE AS SHOWN.

Wiring Diagram: Outputs

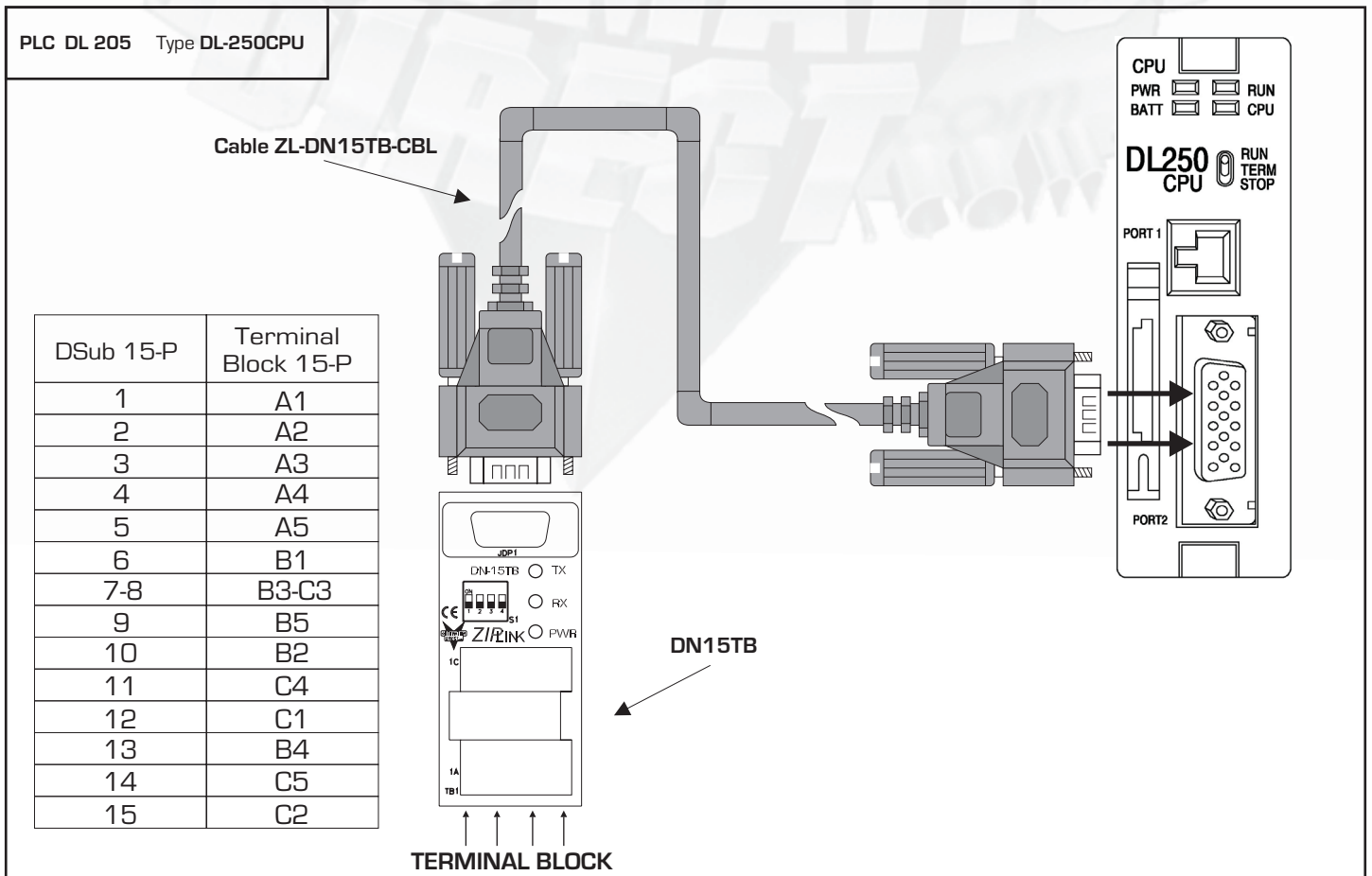

Connecting RS232

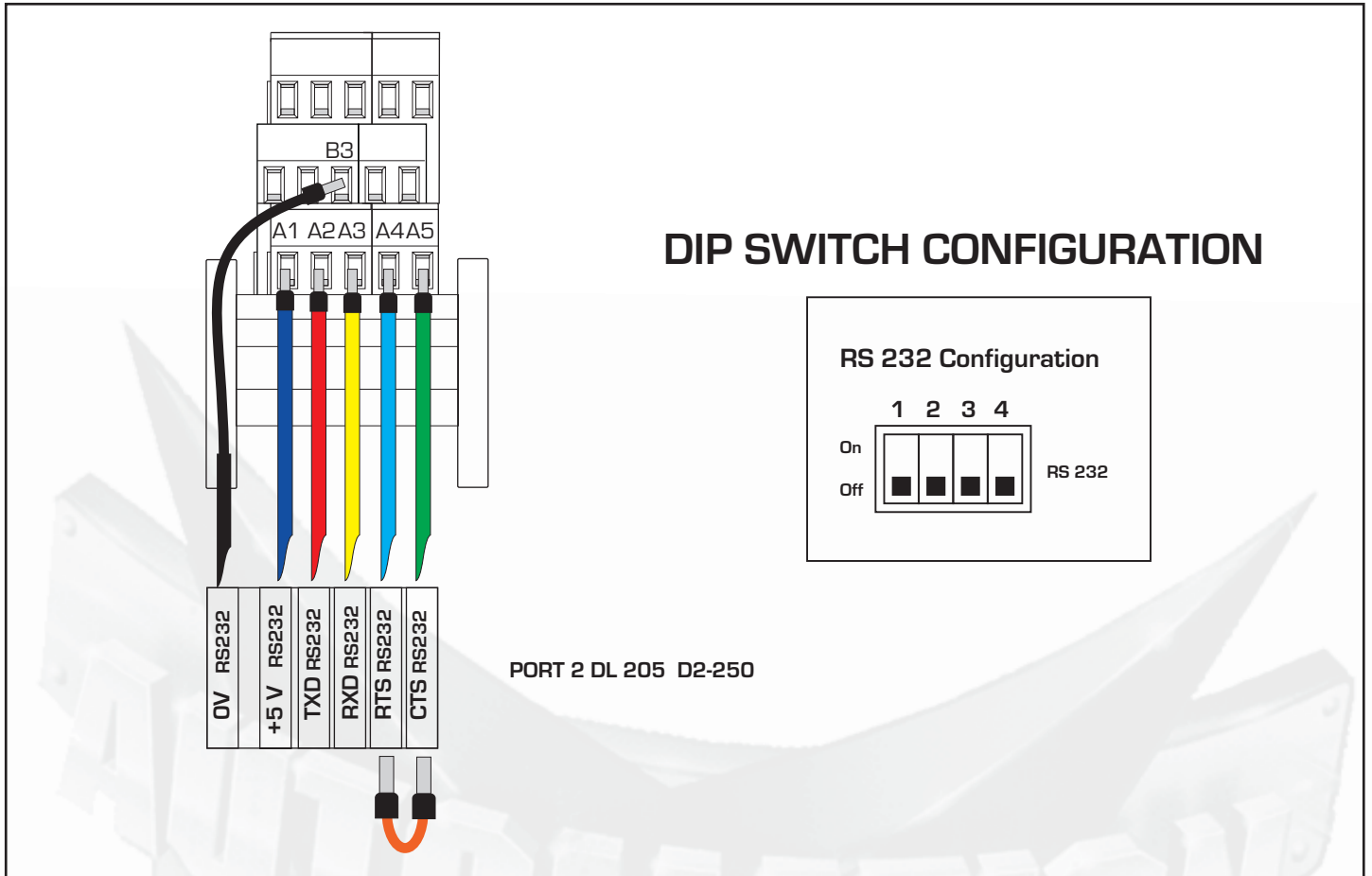

Connecting RS422 / Remote I/O

