

Flat Light

Infrared, 200 × 200 mm

OPT2419

Part Number



- Easy and flexible installation
- High homogeneity
- High performance: high intensity even in continuous mode
- No external control required

wenglor backlights are ideally suited for machine vision applications (e.g. silhouette lighting) in areas from 200 × 200 mm. They can be used in continuous mode or synchronized with the Machine Vision Camera in strobe mode via PNP or NPN inputs. Thanks to their diffused light, the backlights are ideal for applications with transmitted light or incident light. The illumination is extremely homogeneous with very small borders (4 mm), so the usable surface is very large and integration is very easy – thanks, among other things, to the T-slot mounting and anchor point on the entire housing of the illumination

Technical Data

Optical Data	
Light Source	Infrared Light
Wavelength	850 nm
Risk Group (EN 62471)	1
Light output	≤ 45000 Lux
Electrical Data	
Supply Voltage	24 V DC
Power	27,52 W
Current Consumption Continuous Mode (U _b = 24 V)	1,15 A
Duty cycle	15 μs
Fall time	10 μs
Input signal	PNP/NPN
Temperature Range	-10...40 °C
Storage temperature	-20...60 °C
Short Circuit Protection	yes
Reverse Polarity Protection	yes
Overload Protection	yes
Protection Class	III
Dimming	0...10 V ± 100...30%
Overdrive	no
Mechanical Data	
Luminous Field Length (L)	200 mm
Luminous Field Width (W)	200 mm
Luminous Field	200 × 200 mm
Housing Material	Aluminum, fiberglass-reinforced ABS
Degree of Protection	IP40
Optic Cover	PMMA (diffuse)
Connection	M12 × 1; 5-pin
Max. cable length	10 m
Weight	< 1000 g
Function	
Operating modes	Continuous, Strobe
Connection Diagram No.	007
Control Panel No.	T16
Suitable Mounting Technology No.	926

Complementary Products

Mounting Bracket OPT2433

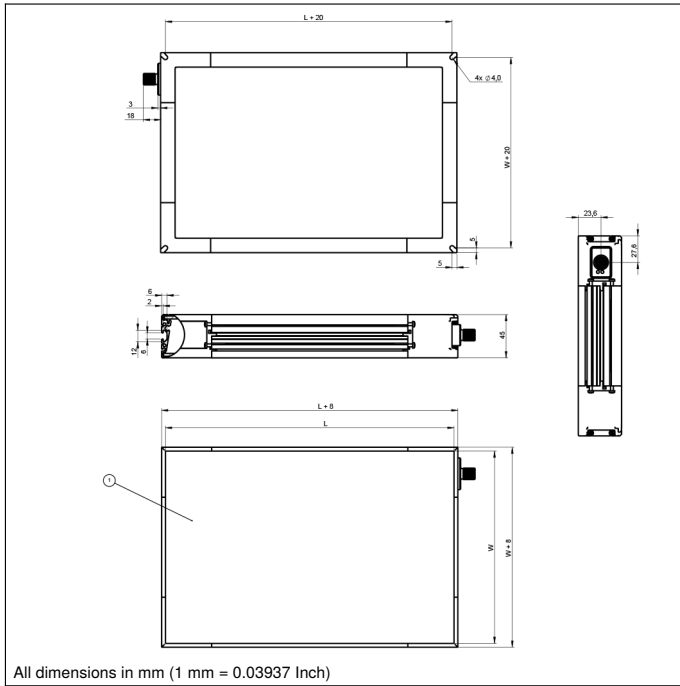

All dimensions in mm (1 mm = 0.03937 Inch)

Ctrl. Panel

T16

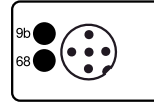

68 = supply voltage indicator
 9b = Strobe Mode Indicator

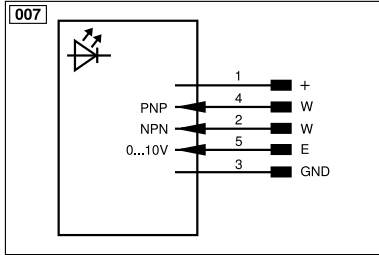

Legend			
+	Supply Voltage +	nc	Not connected
-	Supply Voltage 0 V	U	Test Input
~	Supply Voltage (AC Voltage)	Ū	Test Input inverted
A	Switching Output (NO)	W	Trigger Input
Ā	Switching Output (NC)	W-	Ground for the Trigger Input
V	Contamination/Error Output (NO)	O	Analog Output
ȳ	Contamination/Error Output (NC)	O-	Ground for the Analog Output
E	Input (analog or digital)	BZ	Block Discharge
T	Teach Input	Amv	Valve Output
Z	Time Delay (activation)	a	Valve Control Output +
S	Shielding	b	Valve Control Output 0 V
RxD	Interface Receive Path	SY	Synchronization
TxD	Interface Send Path	SY-	Ground for the Synchronization
RDY	Ready	E+	Receiver-Line
GND	Ground	S+	Emitter-Line
CL	Clock	±	Grounding
E/A	Output/Input programmable	SnR	Switching Distance Reduction
IO-Link		Rx+/-	Ethernet Receive Path
PoE	Power over Ethernet	Tx+/-	Ethernet Send Path
IN	Safety Input	Bus	Interfaces-Bus A(+)/B(-)
OSSD	Safety Output	La	Emitted Light disengageable
Signal	Signal Output	Mag	Magnet activation
BI_D+/-	Ethernet Gigabit bidirect. data line (A-D)	RES	Input confirmation
ENo RS422	Encoder 0-pulse 0/0 (TTL)	EDM	Contactor Monitoring
PT	Platinum measuring resistor	ENARs422	Encoder A/Ā (TTL)
			Encoder B/Ĕ (TTL)
			Encoder A
			Encoder B
			Digital output MIN
			Digital output MAX
			Digital output OK
			Synchronization In
			Synchronization OUT
			Brightness output
			Maintenance
			Reserved
			Wire Colors according to DIN IEC 60757
			BK Black
			BN Brown
			RD Red
			OG Orange
			YE Yellow
			GN Green
			BU Blue
			VT Violet
			GY Grey
			WH White
			PK Pink
			GNYE Green/Yellow

