

# Flat Light

White light, 200 × 200 mm

## OPT2418

Part Number



- Easy and flexible installation
- High homogeneity
- High performance: high intensity even in continuous mode
- No external control required

wenglor backlights are ideally suited for machine vision applications (e.g. silhouette lighting) in areas from 200 × 200 mm. They can be used in continuous mode or synchronized with the Machine Vision Camera in strobe mode via PNP or NPN inputs. Thanks to their diffused light, the backlights are ideal for applications with transmitted light or incident light. The illumination is extremely homogeneous with very small borders (4 mm), so the usable surface is very large and integration is very easy – thanks, among other things, to the T-slot mounting and anchor point on the entire housing of the illumination

### Technical Data

Optical Data	
Light Source	White Light
Color temperature	5700 K
Light output	≤ 45000 Lux
Electrical Data	
Supply Voltage	24 V DC
Power	21,6 W
Current Consumption Continuous Mode (U <sub>b</sub> = 24 V)	0,9 A
Duty cycle	15 μs
Fall time	10 μs
Input signal	PNP/NPN
Temperature Range	-10...40 °C
Storage temperature	-20...60 °C
Short Circuit Protection	yes
Reverse Polarity Protection	yes
Overload Protection	yes
Protection Class	III
Dimming	0...10 V ± 100...30%
Overdrive	no
Mechanical Data	
Luminous Field Length (L)	200 mm
Luminous Field Width (W)	200 mm
Luminous Field	200 × 200 mm
Housing Material	Aluminum, fiberglass-reinforced ABS
Degree of Protection	IP40
Optic Cover	PMMA (diffuse)
Connection	M12 × 1; 5-pin
Max. cable length	10 m
Weight	< 1000 g
Function	
Operating modes	Continuous, Strobe
Connection Diagram No.	<b>007</b>
Control Panel No.	<b>T16</b>
Suitable Mounting Technology No.	<b>926</b>

### Complementary Products

Mounting Bracket OPT2433

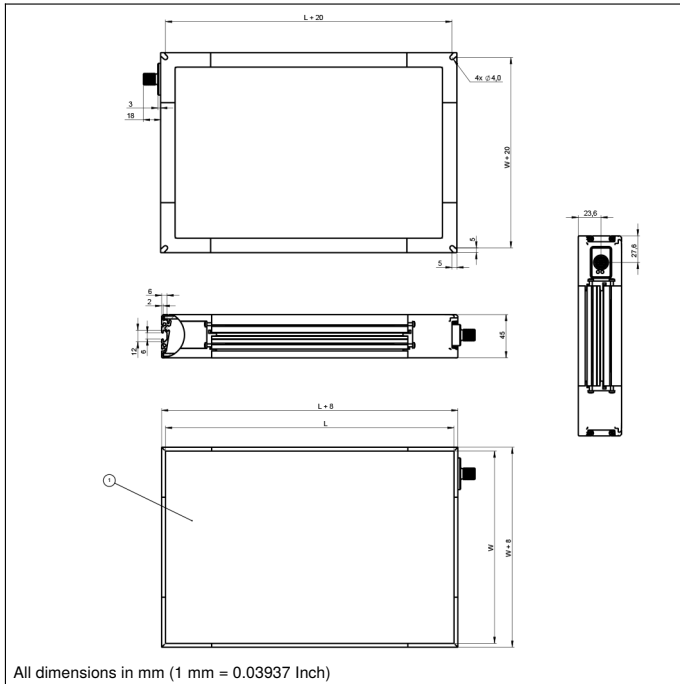

All dimensions in mm (1 mm = 0.03937 Inch)

## Ctrl. Panel

**T16**

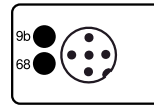

68 = supply voltage indicator  
 9b = Strobe Mode Indicator

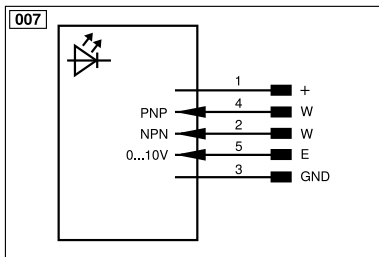

Legend					
+	Supply Voltage +	nc	Not connected	EN <sub>RS422</sub>	Encoder B/Ā (TTL)
-	Supply Voltage 0 V	U	Test Input	ENA	Encoder A
~	Supply Voltage (AC Voltage)	Ū	Test Input inverted	EN <sub>b</sub>	Encoder B
A	Switching Output (NO)	W	Trigger Input	AMIN	Digital output MIN
Ā	Switching Output (NC)	W-	Ground for the Trigger Input	AMAX	Digital output MAX
V	Contamination/Error Output (NO)	O	Analog Output	AOK	Digital output OK
Ū	Contamination/Error Output (NC)	O-	Ground for the Analog Output	SY In	Synchronization In
E	Input (analog or digital)	BZ	Block Discharge	SY OUT	Synchronization OUT
T	Teach Input	Amv	Valve Output	OLT	Brightness output
Z	Time Delay (activation)	a	Valve Control Output +	M	Maintenance
S	Shielding	b	Valve Control Output 0 V	rsv	Reserved
RxD	Interface Receive Path	SY	Synchronization	Wire Colors according to DIN IEC 60757	
TxD	Interface Send Path	SY-	Ground for the Synchronization	BK	Black
RDY	Ready	E+	Receiver-Line	BN	Brown
GND	Ground	S+	Emitter-Line	RD	Red
CL	Clock	±	Grounding	OG	Orange
E/A	Output/Input programmable	SnR	Switching Distance Reduction	YE	Yellow
	<b>IO-Link</b>	Rx+/-	Ethernet Receive Path	GN	Green
PoE	Power over Ethernet	Tx+/-	Ethernet Send Path	BU	Blue
IN	Safety Input	Bus	Interfaces-Bus A(+)/B(-)	VT	Violet
OSSD	Safety Output	La	Emitted Light disengageable	GY	Grey
Signal	Signal Output	Mag	Magnet activation	WH	White
BI_D+/-	Ethernet Gigabit bidirect. data line (A-D)	RES	Input confirmation	PK	Pink
EN <sub>RS422</sub>	Encoder 0-pulse 0/0 (TTL)	EDM	Contact Monitoring	GNYE	Green/Yellow
PT	Platinum measuring resistor	EN <sub>AR422</sub>	Encoder A/Ā (TTL)		

