

# OPT2205

Ultrasonic Distance Sensor



## Operating instructions

# Table of Contents

<b>1. General</b> .....	<b>3</b>
1.1 General Information Concerning these Instructions .....	3
1.2 Explanations of Symbols .....	3
1.3 Limitation of Liability .....	4
1.4 Copyrights.....	4
<b>2. For Your Safety</b> .....	<b>5</b>
2.1 Use for Intended Purpose.....	5
2.2 Use for Other than the Intended Purpose.....	5
2.3 Personnel Qualifications .....	6
2.4 Modification of Products .....	6
2.5 General Safety Precautions.....	6
2.6 Approvals and protection class.....	6
<b>3. Technical Data</b> .....	<b>7</b>
3.1 Warm-Up Phase .....	8
3.2 Mode-Dependent Data .....	8
3.3 Sonic Cone Diagrams.....	9
3.4 Housing Dimensions.....	10
3.5 Connection Diagram.....	11
3.6 Complementary Products (see catalog) .....	12
3.7 Layout .....	12
3.8 Control panel .....	13
3.9 Scope of Delivery.....	13
<b>4. Transport and Storage</b> .....	<b>14</b>
4.1 Transport .....	14
4.2 Storage .....	14
<b>5. Installation and Electrical Connection</b> .....	<b>15</b>
5.1 Installation.....	15
5.2 Electrical Connection .....	15
5.3 Diagnosis .....	16
5.3.1 LED Indicators.....	16
5.3.2 Troubleshooting .....	17
<b>6. Delivery status</b> .....	<b>17</b>
<b>7. Settings via IO-Link</b> .....	<b>18</b>
7.1 Foreground Teach-In .....	18
7.2 Window Teach-In.....	18
7.3 Filter.....	19
7.4 Mute mode of operation.....	20
7.5 Hysteresis .....	20
<b>8. Maintenance Instructions</b> .....	<b>21</b>
<b>9. Proper Disposal</b> .....	<b>21</b>
<b>10. Appendix</b> .....	<b>21</b>
10.1 Change Index, Operating Instructions .....	21
10.2 EU/UKCA Declaration of Conformity .....	21

# 1. General

## 1.1 General Information Concerning these Instructions

- These instructions are valid for the product OPT2205.
- They make it possible to use the product safely and efficiently.
- These instructions are an integral part of the product and must be kept on hand for the entire duration of its service life.
- Local accident prevention regulations and national work safety regulations must be complied with as well.
- The product is subject to further technical development, and thus the information contained in these operating instructions may also be subject to change.



### NOTE!

The operating instructions must be read carefully before using the product and must be kept on hand for later reference.

## 1.2 Explanations of Symbols

- Safety precautions and warnings are emphasized by means of symbols and attention-getting words.
- Safe use of the product is only possible if these safety precautions and warnings are adhered to.

The safety precautions and warnings are laid out in accordance with the following principle:



### ATTENTION-GETTING WORD!

#### Type and Source of Danger!

Possible consequences in the event that the hazard is disregarded.

- Measures for averting the hazard.

The meanings of the attention-getting words, as well as the scope of the associated hazards, are listed below:



### DANGER!

This word indicates a hazard with a high degree of risk which, if not avoided, results in death or severe injury.



### WARNING!

This word indicates a hazard with a medium degree of risk which, if not avoided, may result in death or severe injury.



### CAUTION!

This word indicates a hazard with a low degree of risk which, if not avoided, may result in minor or moderate injury.



### ATTENTION:

This word draws attention to a potentially hazardous situation which, if not avoided, may result in property damage.



### NOTE!

A note draws attention to useful tips and suggestions, as well as information regarding efficient, error-free use.

### **1.3 Limitation of Liability**

- The product has been developed in consideration of the current state-of-the-art and applicable standards and guidelines. Subject to change without notice.
- wenglor sensoric elektronische Geräte GmbH (hereinafter referred to as “wenglor”) excludes all liability in the event of:
  - Non-compliance with the instructions
  - Use of the product for purposes other than those intended
  - Use by untrained personnel
  - Use of unapproved replacement parts
  - Unapproved modification of products
- These operating instructions do not imply any guarantee from wenglor with regard to the described procedures or specific product characteristics.
- wenglor assumes no liability for printing errors or other inaccuracies contained in these operating instructions, unless wenglor was verifiably aware of such errors at the point in time at which the operating instructions were prepared.

### **1.4 Copyrights**

- The contents of these instructions are protected by copyright law.
- All rights are reserved by wenglor.
- Commercial reproduction or any other commercial use of the provided content and information, in particular graphics and images, is not permitted without previous written consent from wenglor.

## 2. For Your Safety

### 2.1 Use for Intended Purpose

This sensor is used to detect objects and measure distances.

Ultrasonic Sensors emit pulsed ultrasonic waves at a certain frequency using air as a transmitting medium. The sensors evaluate the transit time of the ultrasound reflected from the object. The output is switched when the preselected switching point is reached. Furthermore, the measured value can be read out via IO-Link 1.1.

The product may be used only in areas with the specified ambient conditions (see the technical data on the product detail page). Furthermore, the guidelines, safety data, and approvals specified in the technical data must be taken into account.

This product can be used for object detection or distance measurement in the following industry sectors:

- Special-purpose machinery manufacturing
- Heavy machinery manufacturing
- Logistics
- Automotive industry
- Packaging industry
- Pharmaceuticals industry
- Clothing industry
- Plastics industry
- Woodworking industry
- Consumer goods industry
- Paper industry
- Electronics industry
- Glass industry
- Steel industry
- Printing industry
- Aviation industry
- Construction industry
- Chemicals industry
- Agriculture industry
- Alternative energies
- Raw materials extraction

### 2.2 Use for Other than the Intended Purpose

- Not a safety component in accordance with 2006/42/EC (Machinery Directive).
- The product is not suitable for use in potentially explosive atmospheres.
- The product may only be used with accessories supplied or approved by wenglor, or combined with approved products. A list of approved accessories and combination products can be accessed at [www.automationdirect.com](http://www.automationdirect.com) on the product detail page.



#### **DANGER!**

#### **Risk of personal injury or property damage in case of use for other than the intended purpose!**

Use for other than the intended purpose may lead to hazardous situations.

- Observe instructions regarding use for intended purpose.
-

## 2.3 Personnel Qualifications

- Suitable technical training is a prerequisite.
- In-house electronics training is required.
- Trained personnel who use the product must have uninterrupted access to the operating instructions.



### **DANGER!**

**Risk of personal injury or property damage in case of incorrect initial start-up and maintenance!**

Personal injury and damage to equipment may occur.

- Adequate training and qualification of personnel.
- 

## 2.4 Modification of Products



### **DANGER!**

**Risk of personal injury or property damage if the product is modified!**

**Personal injury and damage to equipment may occur. Non-observance may result in loss of the CE marking and the guarantee may be rendered null and void.**

- Modification of the product is impermissible.
- 

## 2.5 General Safety Precautions



### **NOTE!**

- These instructions are an integral part of the product and must be kept on hand for the entire duration of its service life.
- Read the operating instructions carefully before using the product.
- Protect the sensor against contamination and mechanical influences.

## 2.6 Approvals and protection class

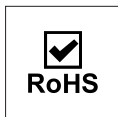

### 3. Technical Data

Technical Data	Order No.	OPT2205
<b>Ultrasound Data</b>		
Working Range, Reflex Sensor		80...400 mm
Setting Range		80...400 mm
Reproducibility		1 mm
Linearity deviation		3 mm
Resolution		0,5 mm
Ultrasonic Frequency		300 kHz
Aperture Angle		< 14°
Service Life (ambient temp. = +25° C)		100000 h
Switching Hysteresis		1 % of the switching distance, at least 2 mm
<b>Electrical Data</b>		
Supply Power*		18...30 V DC
Current Consumption (operating voltage = 24 V)		< 30 mA
Switching Frequency, Reflex Sensor		18 Hz
Response Time, Reflex Sensor		28 ms
Temperature Range		-30...60 °C
Number of Switching Outputs		1
Switching Output Voltage Drop		< 2,5 V
Switching Output Switching Current		100 mA
Short-Circuit Proof		yes
Reverse Polarity and Overload-Proof		yes
Interface		IO-Link
IO-Link Version		1.1
Data Storage		yes
Protection Class		III
<b>Mechanical Data</b>		
Setting Method		IO-Link
Housing Material		Plastic, PBT
Sleeve Material		Nickel-plated brass
Nut Material		Plastic, PA
Degree of Protection		IP67, IP68
Connector Type		M12×1; 4-pin
<b>Technical Safety Data</b>		
MTTFd (EN ISO 13849-1)		1.369,42 a
<b>Functions</b>		
Configurable as PNP/NPN		yes
Programmable as NC/NO		yes
Programmable Error Output		yes
IO-Link**		yes

\* Start-up time: 1,400 ms

\*\* IO-Link ready after 350 ms

### 3.1 Warm-Up Phase

The warm-up phase lasts roughly 30 minutes. At the beginning of the warm-up phase, linearity deviation and reproducibility may deviate from the specified values. During the warm-up phase, the values improve in the form of an exponential function until the values in the technical data are reached.

### 3.2 Mode-Dependent Data

Some technical data depend on the filter set. Depending on the setting, the following data are obtained:

Reflex-mode operation

Filter value	Switching Frequency (Hz)	Response Time (ms)
0	18,0	27,8
1	13,5	37,0
2	11,3	44,4
3	10,1	49,6
4	9,0	55,6
5	8,1	61,7
6	7,3	68,6
7	6,8	74,1
8	6,2	80,5
9	5,8	86,8
10	5,4	92,6
11	5,0	99,2
12	4,7	106,8
13	4,5	111,1
14	4,2	118,2
15	4,1	123,5
16*	3,8	132,3
17*	3,6	138,9
18*	3,5	142,5
19*	3,3	150,2
20*	3,2	154,3

\* The specified switching frequency and response time correspond to the maximum duration including the interference filter. A detailed description of the filter function can be found in section "7.3 Filter" on page 19.



### 3.3 Sonic Cone Diagrams

Measurement of the sonic cone on a 100 x 100 mm plate

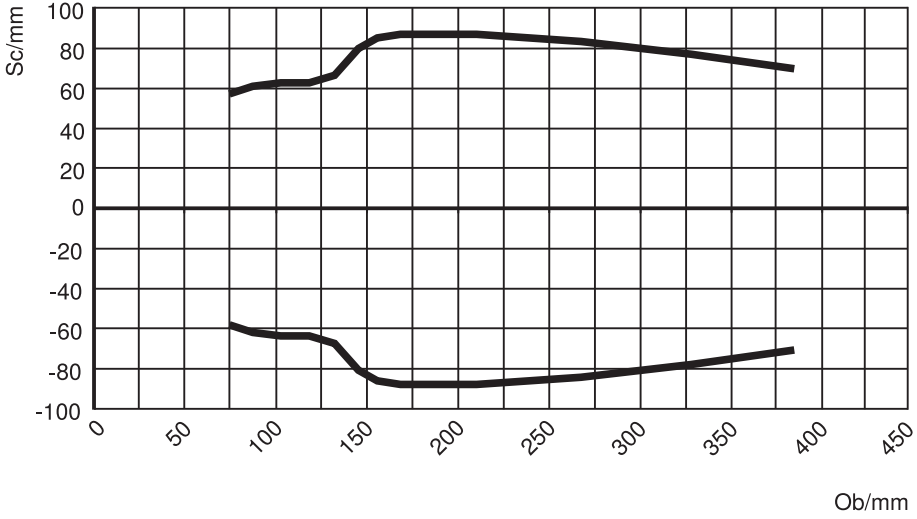

Measurement of the sonic cone on a rod with a diameter of 25 mm

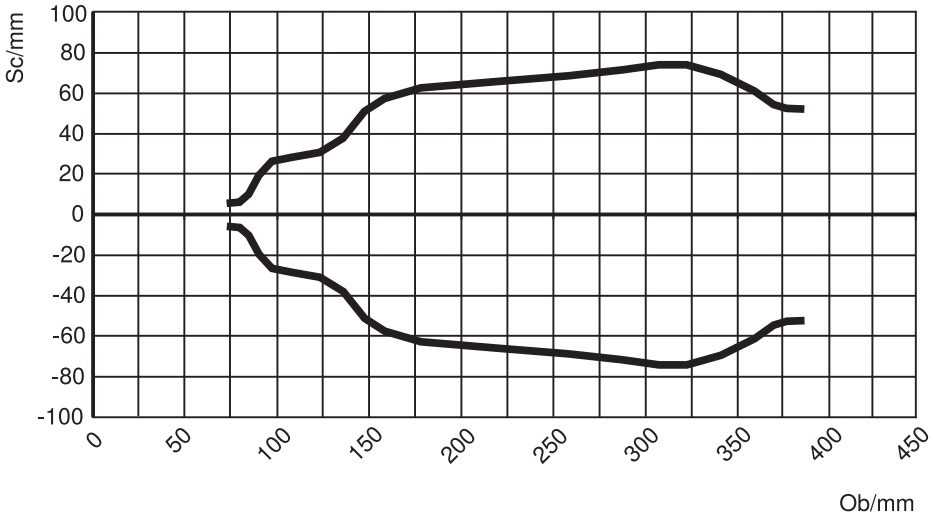

Ob = Object  
Sc = Sonic cone width

### 3.4 Housing Dimensions

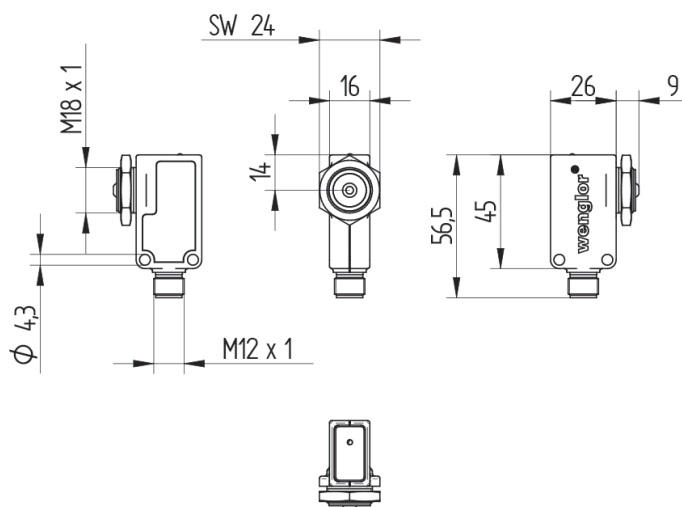

All dimensions in mm  
Screw M3 = 0,5 Nm

### 3.5 Connection Diagram

1028

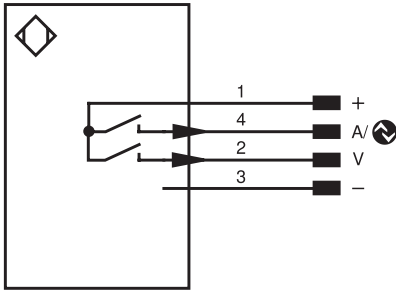

#### Legend

+	Supply Voltage +
-	Supply Voltage 0 V
~	Supply Voltage (AC Voltage)
A	Switching Output (NO)
$\bar{A}$	Switching Output (NC)
V	Contamination/Error Output (NO)
$\bar{V}$	Contamination/Error Output (NC)
E	Input (analog or digital)
T	Teach Input
Z	Time Delay (activation)
S	Shielding
RxD	Interface Receive Path
TxD	Interface Send Path
RDY	Ready
GND	Ground
CL	Clock
E/A	Output/Input programmable
	<b>IO-Link</b>
PoE	Power over Ethernet
IN	Safety Input
QSSD	Safety Output
Signal	Signal Output
BI_LD +/-	Ethernet Gigabit bidirect. data line (A-D)
ENrRS422	Encoder 0-pulse 0-0̇ (TTL)

PT	Platinum measuring resistor
nc	not connected
U	Test Input
$\bar{U}$	Test Input inverted
W	Trigger Input
W-	Ground for the Trigger Input
O	Analog Output
O-	Ground for the Analog Output
BZ	Block Discharge
AWV	Valve Output
a	Valve Control Output +
b	Valve Control Output 0 V
SY	Synchronization
SY-	Ground for the Synchronization
E+	Receiver-Line
S+	Emitter-Line
$\pm$	Grounding
SnR	Switching Distance Reduction
Rx +/-	Ethernet Receive Path
Tx +/-	Ethernet Send Path
Bus	Interfaces-Bus A(+)/B(-)
La	Emitted Light disengageable
Mag	Magnet activation
RES	Input confirmation
EDM	Contactor Monitoring

ENrRS422	Encoder A/Ā (TTL)
ENrRS422	Encoder B/B̄ (TTL)
ENa	Encoder A
ENb	Encoder B
AMIN	Digital output MIN
AMAX	Digital output MAX
AOK	Digital output OK
SY In	Synchronization In
SY OUT	Synchronization OUT
OLT	Brightness output
M	Maintenance
rSV	reserved
Wire Colors according to IEC 60757	
BK	Black
BN	Brown
RD	Red
OG	Orange
YE	Yellow
GN	Green
BU	Blue
VT	Violet
GY	Grey
WH	White
PK	Pink
GNYE	Green/Yellow

### 3.6 Complementary Products (see catalog)

wenglor offers Connection Technology for field wiring.

Suitable Mounting Technology No.

2

S02

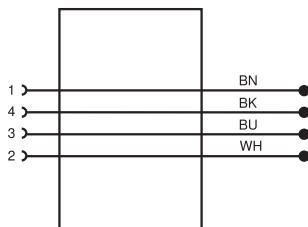

IO-Link-Master

### 3.7 Layout

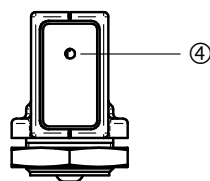
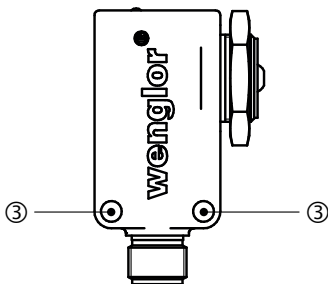
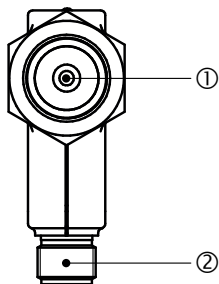

- ① = Sensing Face
- ② = Plug Connector
- ③ = Mounting Holes
- ④ = Indicator LED

## 3.8 Control panel

R3

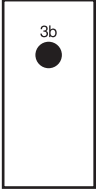

3b = supply voltage / switching status indicator / error

### Meaning of the colors of the status LED:

Green: Supply voltage

Yellow: Switching status indicator

Red: Error

## 3.9 Scope of Delivery

- 1 ultrasonic reflex sensor OPT2205
- 1 plastic nut (NUT-M18-E012)
- 1 instruction leaflet

## 4. Transport and Storage

### 4.1 Transport

Upon receipt of shipment, inspect the goods for damage in transit. In the case of damage, conditionally accept the package and notify the manufacturer of the damage. Then return the device making reference to damage in transit.

### 4.2 Storage

**The following points must be taken into condition with regard to storage:**

- Do not store the product outdoors.
- Store the product in a dry, dust-free place.
- Protect the product against mechanical impacts.
- Protect the product against exposure to direct sunlight.



**ATTENTION:**

**Risk of property damage in case of improper storage!**

The product may be damaged.

- Comply with storage instructions.
-

## 5. Installation and Electrical Connection

### 5.1 Installation

- Protect the product from contamination during installation.
- Observe all applicable electrical and mechanical regulations, standards, and safety rules.
- Protect the product against mechanical influences.
- Make sure that the sensor is mounted in a mechanically secure fashion.
- If the object has smooth surfaces, the angle between the axis of the sound waves and the surface of the object should be  $90^\circ \pm 3^\circ$ . The angle can be considerably larger in the case of rough object surfaces.
- The sensor's sensing face must remain unobstructed.



#### NOTE!

#### Observe the blind spot.

In the area between the sensor's active surface and the beginning of its working range, correct functioning of the sensor is not assured. No objects may be located in this area.

	Object position			Switching position / switching LED	Error output / error LED	Measured value, IO-Link
Working range		x		Defined	Defined	Defined
Blind spot	x			Undefined	Undefined	Undefined
Above the working range			x	Defined	Defined	Defined



#### ATTENTION!

#### Risk of property damage in case of improper installation!!

The product may be damaged.

- Comply with installation instructions.



#### CAUTION!

#### Risk of personal injury or property damage during installation!

Personal injury and damage to the product may occur.











- Ensure a safe installation environment.

### 5.2 Electrical Connection

Connect the sensor to 18 to 30 V DC (see section "3.5 Connection Diagram", page 11).

## 5.3 Diagnosis

### 5.3.1 LED Indicators

Indicator	Status	Meaning
<b>Parameter configuration: A1 switching output normally closed (NC) and A2 error output normally open (NO)</b>		
Supply voltage / switching status indicator / error	 Error indicator	<ul style="list-style-type: none"> <li>No object detectable</li> <li>Error output on</li> <li>Switching output on</li> </ul>
	 Error indicator	<ul style="list-style-type: none"> <li>Object above measuring range</li> <li>Error output on</li> <li>Switching output on</li> </ul>
	 Switching status indicator	<ul style="list-style-type: none"> <li>Object above switching point</li> <li>Error output off</li> <li>Switching output on</li> </ul>
	 Supply voltage	<ul style="list-style-type: none"> <li>Object below switching point</li> <li>Error output off</li> <li>Switching output off</li> </ul>
	 Supply voltage	<ul style="list-style-type: none"> <li>Weak object below switching point</li> <li>Error output off</li> <li>Switching output off</li> </ul>
<b>Parameter configuration: A1 switching output normally open (NO) and A2 error output normally open (NO)</b>		
Supply voltage / switching status indicator / error	 Supply voltage	<ul style="list-style-type: none"> <li>No object detectable</li> <li>Error output off</li> <li>Switching output off</li> </ul>
	 Supply voltage	<ul style="list-style-type: none"> <li>Object above measuring range</li> <li>Error output off</li> <li>Switching output off</li> </ul>
	 Supply voltage	<ul style="list-style-type: none"> <li>Object above switching point</li> <li>Error output off</li> <li>Switching output off</li> </ul>
	 Switching status indicator	<ul style="list-style-type: none"> <li>Object below switching point</li> <li>Error output off</li> <li>Switching output on</li> </ul>
	 Error indicator	<ul style="list-style-type: none"> <li>Weak object below switching point</li> <li>Error output on</li> <li>Switching output on</li> </ul>



### 5.3.2 Troubleshooting

Error	Possible Cause	Elimination
Error	Very small or poorly reflective (sound-absorbing) objects are located within the working range	<ul style="list-style-type: none"> <li>• Reduce the distance between the sensor and the object</li> <li>• Adjust the angle to the object</li> </ul>
	The object is located outside of the working range	<ul style="list-style-type: none"> <li>• Adjust the distance between the sensor and the object</li> </ul>
	Incorrect installation	<ul style="list-style-type: none"> <li>• Check installation</li> </ul>
	Excessive environmental influences (strong air turbulence, ultrasonic sources) in the measuring range	<ul style="list-style-type: none"> <li>• Minimize environmental influences</li> </ul>

## 6. Delivery status

Technical Data	OPT2205
Filter	0
Process data type	Outputs and Measured Value
A2 Pin Function	Error Output
A1 Pin Function	Switching Output
Teach Mode	Foreground
A1/A2 PNP/NPN	PNP
A1 NO/NC	NO
A1 Switch Point	400 mm
A1 Hysteresis Additional	0 mm
A2 NO/NC	NO

## 7. Settings via IO-Link

Process and parameters data can be found at [www.wenglor.com](http://www.wenglor.com) in the product's separate download area. Further settings can be entered to the sensor via the IO-Link interface.

### 7.1 Foreground Teach-In

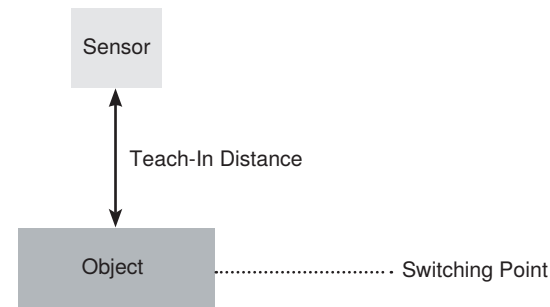

Foreground Teach-In for Switching Output 1

1. Enter the switching point.
2. The sensor is switched when an object is located and the switching point.



#### NOTE!

If there's no object within the measuring range, switching distance is set to the end of the setting range.

### 7.2 Window Teach-In

In addition to foreground teach-in, there's also a window teach-in option:

1. Enter far switching point.
2. Enter near switching point.
3. The sensor is switched when an object is located between the two switching points.

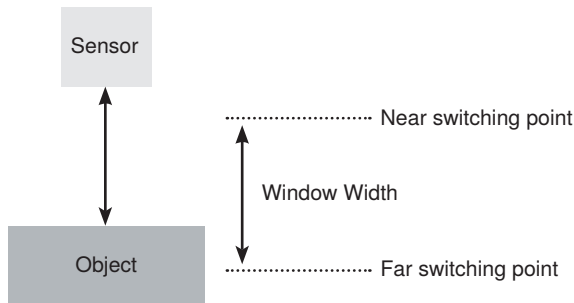

#### NOTE!

The far switching point must be greater than the near switching point.

## 7.3 Filter

The selected filter affects the response time (see response time in section “3. Technical Data” on page 7) and the number of distance values that will be evaluated.

Filter	Description
0 – 15	Median filter Median filter from the specified number of measured values. An error is output if there is no signal or the signal is invalid. This filter can provide additional smoothing of the signal in applications with objects with a homogeneous surface in a stable environment.
0	Median filter from 2 measured values
1	Median filter from 3 measured values
2	Median filter from 4 measured values
3	Median filter from 5 measured values
4	Median filter from 6 measured values
5	Median filter from 7 measured values
6	Median filter from 8 measured values
7	Median filter from 9 measured values
8	Median filter from 10 measured values
9	Median filter from 11 measured values
10	Median filter from 12 measured values
11	Median filter from 13 measured values
12	Median filter from 14 measured values
13	Median filter from 15 measured values
14	Median filter from 16 measured values
15	Median filter from 17 measured values
16 – 20	Median filter and interference filter Median filter from the specified number of measured values. The additional interference filter can be used to increase measurement reliability in the case of brief interferences in the measured section. Interferences such as waves, air vortices, sound-absorbing areas, or bulk goods generate temporarily invalid signals that can lead to incorrect measurements. A higher filter level allows the interfering signals to be ignored for a defined period. If the distance changes continuously, the response time remains unchanged when the filter is activated.
16	Median filter from 18 measured values and bridging of 4 missing measured values (112 ms)
17	Median filter from 21 measured values and bridging of 7 missing measured values (196 ms)
18	Median filter from 24 measured values and bridging of 15 missing measured values (420 ms)
19	Median filter from 27 measured values and bridging of 31 missing measured values (868 ms)
20	Median filter from 36 measured values and bridging of 62 missing measured values (1.7 s)



### NOTE!

The technical data obtained with the various modes are specified in “3. Technical Data” on page 7.

## 7.4 Mute mode of operation

When this mode of operation is activated, the sensor's ultrasonic transmitter (transducer) is switched off. No measurements are taken. The switching behavior is the same as when no signal is received in reflex-mode operation or as a through-beam sensor.

## 7.5 Hysteresis

Hysteresis is the difference between the switch-on and switch-off point.

The sensor has a minimum hysteresis of 1% of the switching distance, but at least 2 mm. This cannot be changed. An additional hysteresis can be set in millimeters for the switching point.

The total hysteresis is calculated by adding the internal switching hysteresis (1%) to the additional hysteresis. The sum of the switching point, hysteresis, and additional hysteresis must not exceed the sensor's maximum measuring range.

## 8. Maintenance Instructions



### NOTE!

- This wenglor sensor is maintenance-free.
- It's advisable to clean and to check the plug connections at regular intervals.
- Do not clean the sensor with solvents or cleansers which could damage the product.
- The product must be protected against contamination during initial start-up.

## 9. Proper Disposal

wenglor sensoric GmbH does not accept the return of unusable or irreparable products. Respectively valid national waste disposal regulations apply to product disposal.

## 10. Appendix

### 10.1 Change Index, Operating Instructions

Version	Date	Description/Change
1.0.0	11/08/2022	Initial version of the operating instructions

### 10.2 EU/UKCA Declaration of Conformity

The declaration of conformity can be found on our website at [www.wenglor.com](http://www.wenglor.com) in the product's separate download area.