

DATA SHEET



Single Phase Induction Motor - Squirrel Cage

Customer		: Automation Direct				
Product line		: Single-Phase		Product code : 14797783 Catalog # : 00118ES1B56C-S		
Frame		: 56C		Locked rotor time : 14s (cold) 8s (hot)		
Output		: 1 HP (0.75 kW)		Temperature rise : 80 K		
Poles		: 4		Duty cycle : Cont.(S1)		
Frequency		: 60 Hz		Ambient temperature : -20°C to +40°C		
Rated voltage		: 115/208-230 V		Altitude : 1000 m.a.s.l.		
Rated current		: 13.6/7.52-6.80 A		Protection degree : IP55		
L. R. Amperes		: 91.1/50.4-45.6 A		Cooling method : IC411 - TEFC		
LRC		: 6.7x(Code M)		Mounting : F-1		
No load current		: 9.60/4.14-4.80 A		Rotation ¹ : Both (CW and CCW)		
Rated speed		: 1745 rpm		Noise level ² : 54.0 dB(A)		
Slip		: 3.06 %		Starting method : Direct On Line		
Rated torque		: 3.01 ft.lb		Approx. weight ³ : 36.8 lb		
Locked rotor torque		: 280 %				
Breakdown torque		: 270 %				
Insulation class		: F				
Service factor		: 1.15				
Moment of inertia (J)		: 0.1037 sq.ft.lb				
Design		: L				
Output		25%	50%	75%	100%	
Efficiency (%)		59.4	62.0	68.0	71.0	
Power Factor		0.27	0.48	0.60	0.68	
		Foundation loads				
		Max. traction : 61 lb				
		Max. compression : 98 lb				
		<u>Drive end</u>		<u>Non drive end</u>		
Bearing type		: 6204 ZZ		: 6202 ZZ		
Sealing		: V'Ring		: Without Bearing Seal		
Lubrication interval		: -		: -		
Lubricant amount		: -		: -		
Lubricant type		: Mobil Polyrex EM				
Notes						
This revision replaces and cancel the previous one, which must be eliminated. (1) Looking the motor from the shaft end. (2) Measured at 1m and with tolerance of +3dB(A). (3) Approximate weight subject to changes after manufacturing process. (4) At 100% of full load.			These are average values based on tests with sinusoidal power supply, subject to the tolerances stipulated in NEMA MG-1.			
Rev.	Changes Summary			Performed	Checked	Date
Performed by						
Checked by					Page	Revision
Date	22/08/2022				1 / 2	

LOAD PERFORMANCE CURVE

Single Phase Induction Motor - Squirrel Cage



Customer : Automation Direct

Product line : Single-Phase

Product code :

14797783

Catalog # :

00118ES1B56C-S

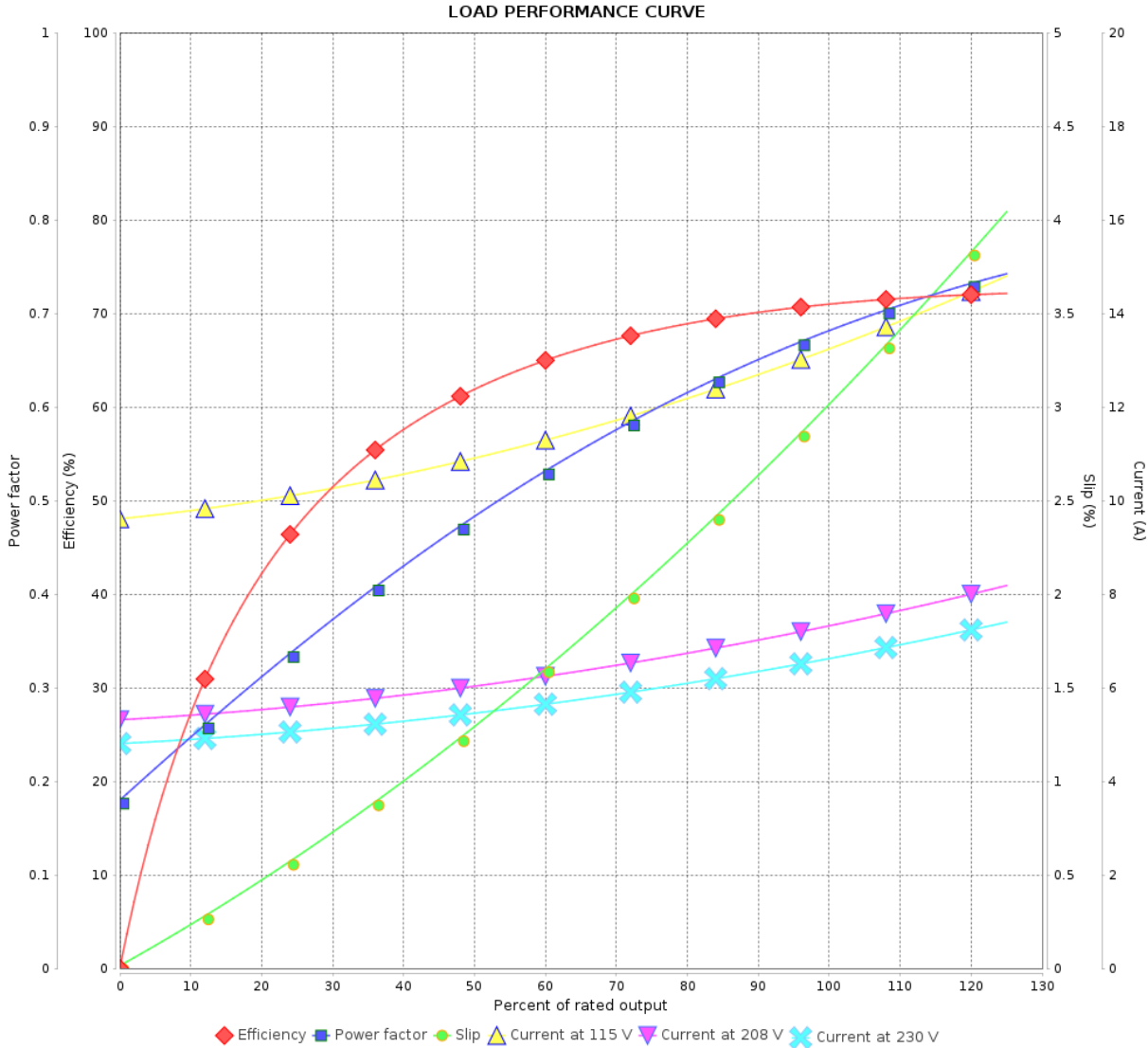

Performance : 115/208-230 V 60 Hz 4P



Rated current : 13.6/7.52-6.80 A
 LRC : 6.7
 Rated torque : 3.01 ft.lb
 Locked rotor torque : 280 %
 Breakdown torque : 270 %
 Rated speed : 1745 rpm

Moment of inertia (J) : 0.1037 sq.ft.lb
 Duty cycle : Cont.(S1)
 Insulation class : F
 Service factor :
 Temperature rise : 80 K
 Design : L

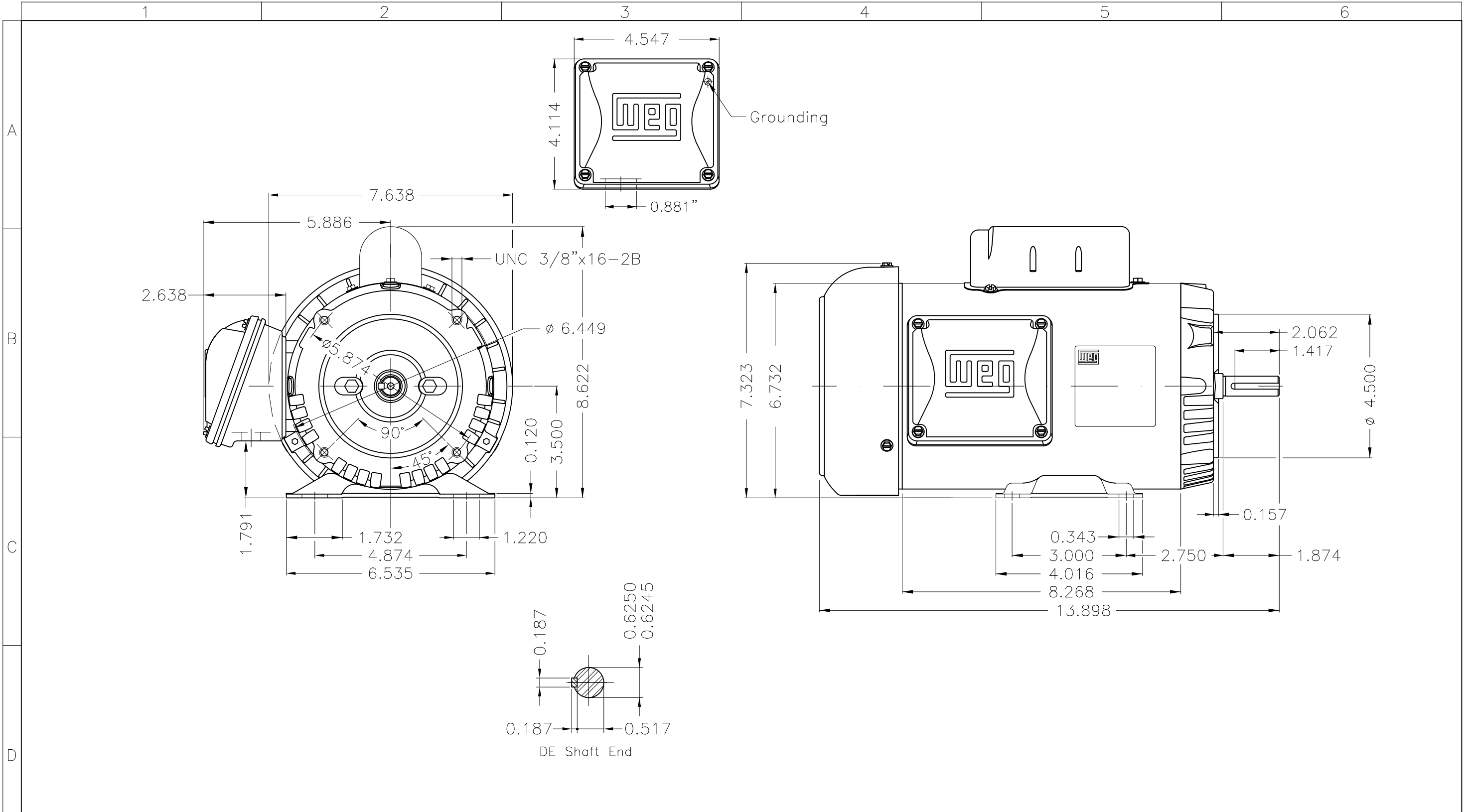
Rev.	Changes Summary	Performed	Checked	Date
Performed by			Page 2 / 2	Revision
Checked by				
Date	22/08/2022			

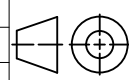

Fan cover - steel plate
 Color Munsell N 1 matte black
 Painting plan 207N
 Mounting F-1/B34R(D)

ECM	LOC	SUMMARY OF MODIFICATIONS	EXECUTED	CHECKED	RELEASED	DATE	VER
EXECUTED	HYBRISUSER	 SINGLE PH. MOTOR ROLLED STEEL FRAME 56C IP55 TEFC					
CHECKED							
RELEASED							
REL DT.	WMO	Jaragua do Sul	Product Engineering	PREVIEW WDD			

1 HP 04 Poles 60 Hz



MADE IN BRAZIL

MAT: 14797783

W01.ME01C0X0X

MODEL 00118ES1B56C-S

01AUG2022 B/N:

PH 1	Hz 60	HP 1.0
FR 56C		KW 0.75
DUTY CONT.		V 115/208-230
ALT 1000 m.a.s.l		A 13.6/7.52-6.80
INS CL F ΔT 80K	IP55	SFA -
AMB 40°C	DES L	SF 1.15
ENCL TEFC	CODE M	PF 0.68
USABLE @ 208V SF1.00		RPM 1745
		AVG. F.L. EFF. 71.0%

Electric Motor

DE 8204-ZZ	ODE 8202-ZZ	MOBIL POLYREX EM	
------------	-------------	------------------	--

REVERSE ROTATION INVERT T5 BY T8

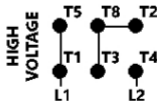
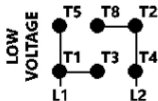

- T1-BLU
- T2-WHT
- T3-ORG
- T4-YEL
- T5-BLK
- T8-RED



WARNING: Motor must be grounded in accordance with local and national electrical codes to prevent serious electrical shocks. Disconnect power source before servicing unit.



AVERTISSEMENT: Le moteur doit être mis à la terre conformément aux codes électriques locaux et nationaux afin d'éviter tout choc électrique grave. Déconnectez l'alimentation avant l'entretien de la machine.

