



Manopla Rotativa para Montagem em Painel MRX (NEMA 4X/IP65)  
 Door Coupling Rotary Handle MRX (NEMA 4X/IP65)  
 Manija Rotativa para Puerta de Tableros MRX (NEMA 4X/IP65)  
 Türkupplungsgriff MRX (NEMA 4X/IP65)

**INSTRUÇÕES DE MONTAGEM**  
**ASSEMBLY INSTRUCTIONS**  
**INSTRUCCIONES DE MONTAJE**  
**MONTAGEANLEITUNG**

Manopla Rotativa para montagem em painel MPW25/MPW40 (MRX / MRX-E) e MPW65/MPW80 (MRX65 / MRX65-E)  
 Door Coupling Rotary Handle MPW25/MPW40 (MRX / MRX-E) and MPW65/MPW80 (MRX65 / MRX65-E)  
 Manija Rotativa para Puerta de Tableros MPW25/MPW40 (MRX / MRX-E) y MPW65/MPW80 (MRX65 / MRX65-E)  
 Türkupplungsgriff MPW25/MPW40 (MRX / MRX-E) und MPW65/MPW80 (MRX65 / MRX65-E)

Compatível com disjuntores-motores MPW25, MPW40, MPW65 e MPW80 a partir da versão "V1A", "V0A", "V3A" e "V0A" respectivamente, ou com "date code" acima de 14142.  
 Compatible with motor-protective-circuit-breaker MPW25, MPW40, MPW65 and MPW80 from version "V1A", "V0A", "V3A" and "V0A" respectively, or date code above 14142.  
 Compatible con guardamotors MPW25, MPW40, MPW65 y MPW80 a partir de la versión "V1A", "V0A", "V3A" e "V0A" respectivamente, o "date code" mayor que 14142.  
 RMMP und RMMP-E kann mit Motorschutzschalter MPW25, MPW40, MPW65 und MPW80 ab Version "V1A", "V0A", "V3A" und "V0A" oder ab "date code" 14142 eingesetzt werden.



Montagem MPW / MPW Assembly  
 Montaje MPW / Einbaulage MPW

Vertical  
 Vertical  
 Vertical  
 Vertikal

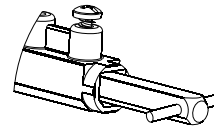

Horizontal  
 Horizontal  
 Horizontal  
 Horizontal

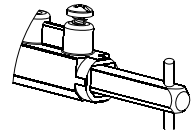

Dimensão mínima para corte do eixo (mm / in)  
 Minimum dimension for cut the shaft (mm / in)  
 Dimensiones mínimas para corte del eje (mm / in)  
 Mindestmaß für das Kürzen der Achse (mm / in)

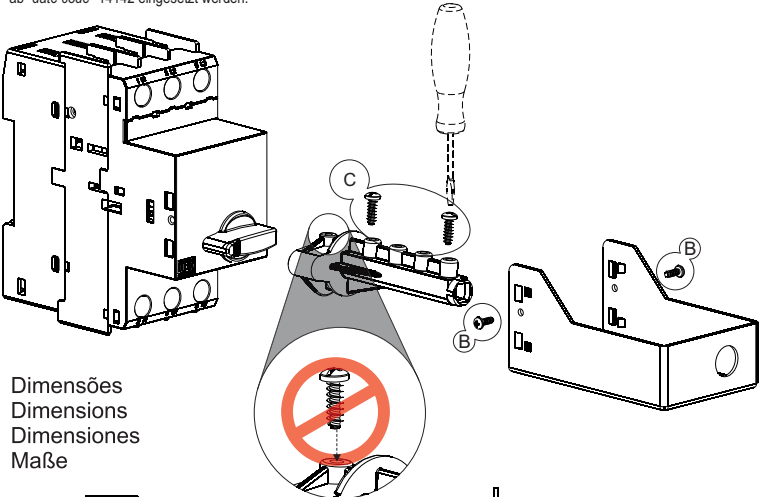
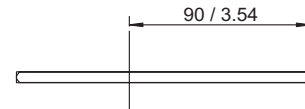

Dimensões  
 Dimensions  
 Dimensiones  
 Maße

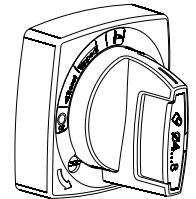
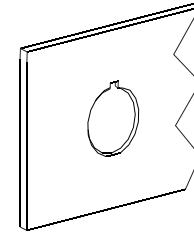
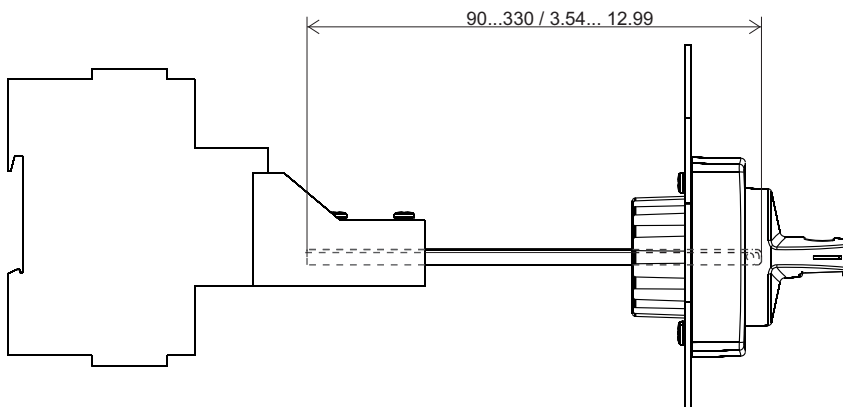
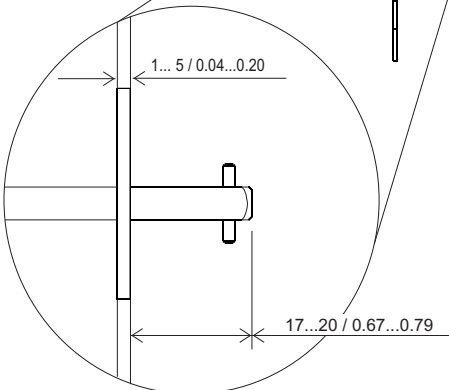
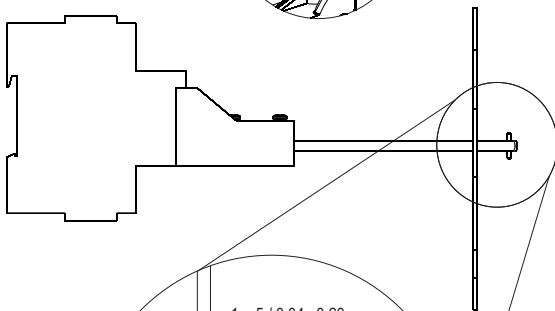

**- Atencão / Warning / Atención / Warnung**

A porta do painel só poderá ser aberta na posição "I" seguindo o procedimento abaixo  
 The panel door only can be opened in the "I" position following the procedure below  
 Apertura de la puerta del tablero en la posición "I" después del procedimiento abajo  
 Die Schaltschranktür kann nur bei Pos. "I", wie unten gezeigt, geöffnet werden.

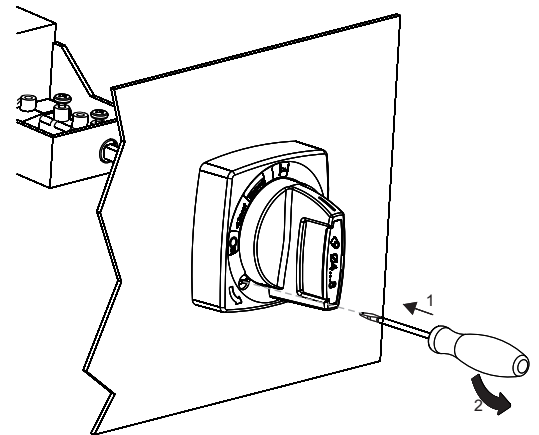

4	A	PHILLIPS #2 Ø3.5 X 14
2	B	PHILLIPS #1 Ø2.2 X 6
2	C	PHILLIPS #2 Ø3 X 10

Opção de cadeado na posição ligado (impossível abertura de porta).  
 Option of locking in ON position (opening panel door is disabled).  
 Opción de candado en posición cerrado (imposible apertura de puerta).  
 Option mit Vorhängeschloss in Pos. EIN (Türöffnung unmöglich).

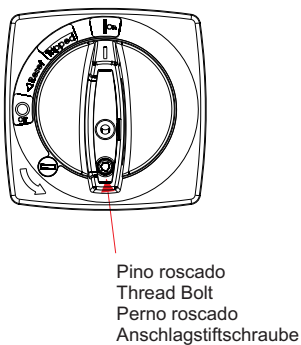
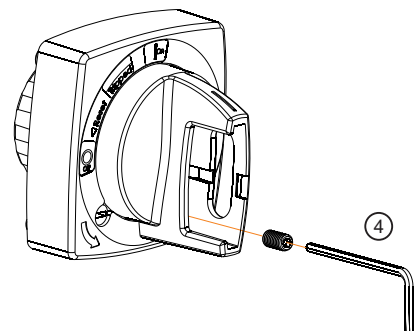
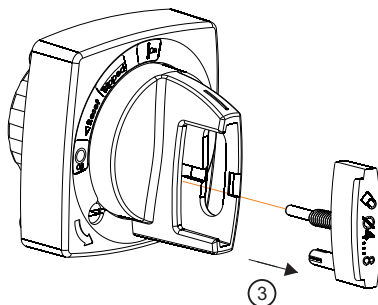
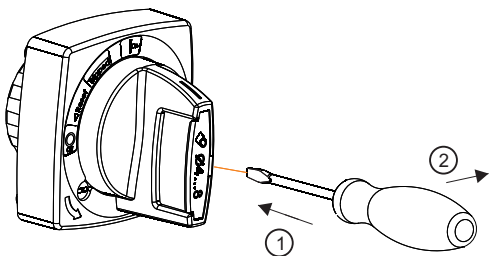

Allen 2.5

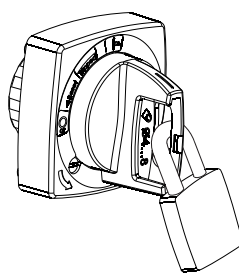
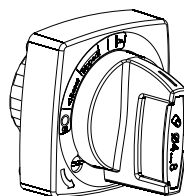
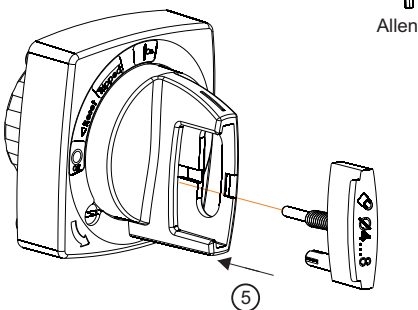

Após remoção do pino roscado o botão tem seu curso liberado na posição ligado.  
 The Push button has its trip free in ON position after removing the threaded bolt.  
 Después de retirar el perno roscado, el pulsador tiene su curso liberado en la posición cerrado.  
 Nach Entfernung der Anschlagstiftschraube kann der Knopf auf Stellung EIN gedreht werden.

Furação da porta do painel  
 Drilling the panel door  
 Agujereado de la puerta del panel  
 Bohren der Schaltschranktür

Opção de montagem com fixação por guia roscado  
 Option of mounting with threaded guide nut  
 Opción de montaje, fijación con buje guía roscado  
 Montageoption mit Gewindeführung

mm / in

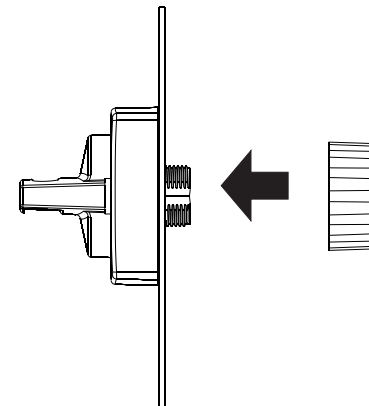
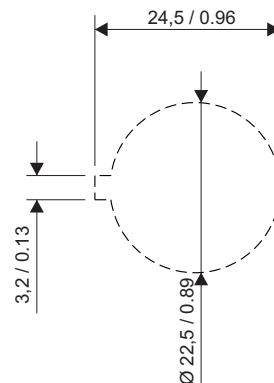

Opção de montagem com fixação por parafusos  
 Option of mounting with screws  
 Opción de montaje, fijación con tornillos.  
 Montageoption mit Schraubenbefestigung

mm / in

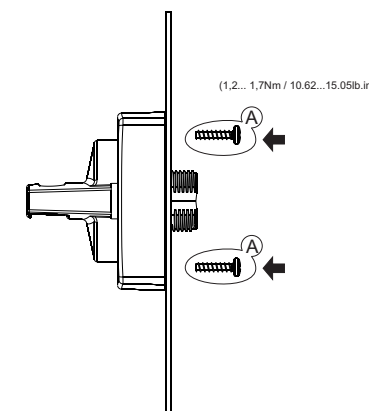
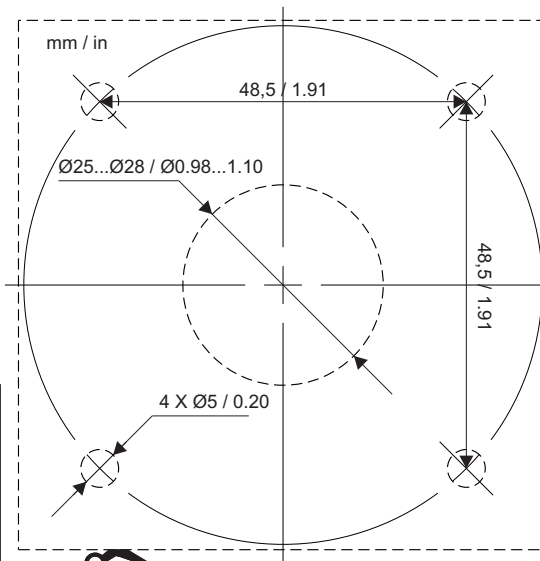

**GARANTIA / WARRANTY / GARANTÍA / GEWÄHRLEISTUNG:**  
 A WEG oferece garantia limitada contra defeitos de fabricação ou de materiais de seus produtos. Para mais informações acesse nosso site:  
 WEG provides a limited warranty for its products against defects in materials and workmanship. For more information access our site:  
 WEG ofrece garantía limitada contra defectos de fabricación o de materiales de sus productos. Para más informaciones acceda al WEB sitio:  
 WEG bietet eine beschränkte Gewährleistung für ihre Produkte gegen Herstellungs- und Materialfehler. Für weitere Informationen besuchen Sie bitte unsere Webseite:  
[www.weg.net/warranty-automation](http://www.weg.net/warranty-automation)

**WEG IMPORTERS IN THE EUROPEAN UNION**  
**AUSTRIA** - WATT DRIVE ANTRIEBSTECHNIK GMBH - Wöllersdorfer Str. 68, 2753 Markt Piesting, Wiener, Austria;  
**BELGIUM** - WEG BENELUX S.A. - Rue de l'Industrie 30/D, 1400 Nivelles, Belgium; **FRANCE** - WEG FRANCE SAS - 13 Rue du Morellon, 38297 Saint Quentin Fallavier, France; **GERMANY** - WEG GERMANY GMBH - Geigerstraße 7, 50169 Industriegebiet Türnich 3, Kerpen, Germany; **ITALY** - WEG ITALIA S.R.L. - Via Viganò de Vizzi, 93/95, 20092 Cinisello Balsamo, Milano, Italy; **NETHERLANDS** - WEG NETHERLANDS - Hanzepoort 23C, 7575 DB Oldenzaal, Netherlands; **PORTUGAL** - WEG EURO-INDUSTRIA ELECTRICA S.A. - R. Eng. Frederico Ulrich 605, 4471-908 Maia, Portugal; **SPAIN** - WEG IBERIA INDUSTRIAL S.L. - C/ Tierra de Barros, 5-7, 28823 Costlada, Madrid, Spain; **SCANDINAVIA** - WEG SCANDINAVIA AB - Box 27, 435 21, 43533 Mölndycke, Sweden; **UNITED KINGDOM** - WEG (UK) LTD - Broad Ground Road, Redditch B988YP, Worcestershire, United Kingdom.  
 Information valid for WEG Group Importers.