

MR200NG
Measuring wheel MR200NG

Circumference 200 mm,
 Surface finish: Synthetic (pimpled Polyurethan)
 Fields of application: rough textiles, carpet, cable measuring, fleece,
 paper, pasteboard, wood, plastic.
 For encoder with shaft \varnothing 10 mm.



Product data

Circumference	200 mm
Surface finish	pimpled Polyurethan
Hardness/Shore A	60
Moment of inertia	$3 \times 10^3 \text{ gcm}^2$
Wheel body material	Aluminum
Standard bore-hole	\varnothing 10 mm
Width	12 mm
Operating temperature	-30 °C up to +80 °C [-22 °F up to +176 °F]
Weight	60 g
Order number MR200NG10	Measuring wheel, bore-hole \varnothing 10 mm

Drawing MR200NG

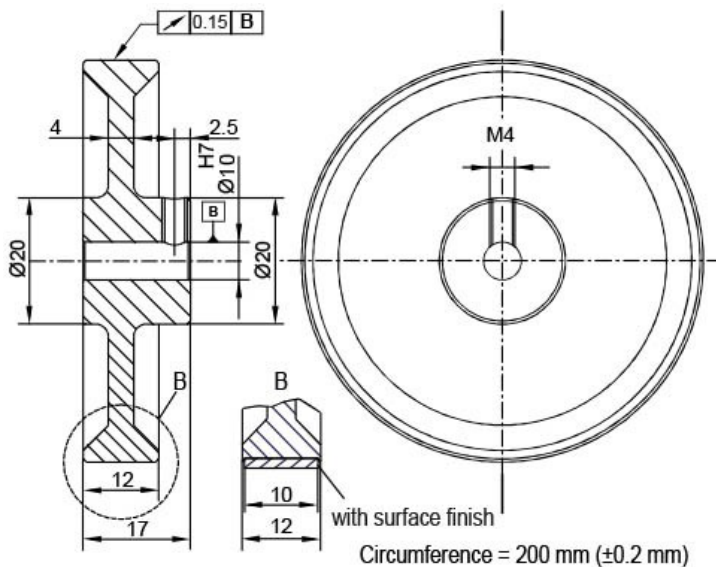

All dimensional specifications in mm

