

### STS-System Benefits

- TÜV certificate according to the legal and standard requirements
- For safety applications up to PLe/Category 4 according to EN/ISO 13849-1
- Modular and expandable system
- Rugged stainless steel design
- Wireless mechanical safeguarding
- Combines the benefits of safety switch, locking module and key transfer in a single system
- Easy installation through comprehensive accessories
- Protection against lock-in

### Features B-ACTUATOR-SET-

A B-ACTUATOR-SET extends an SX-GATE\_SET or ZRH-GATE-SET so that the SX...M or ZRH...M module can be used to protect or to lock a gate mounting it directly on the gate.

### Modification procedure

Example: SX-2GATE-SET with additional B-ACTUATOR-SET:

Initial situation

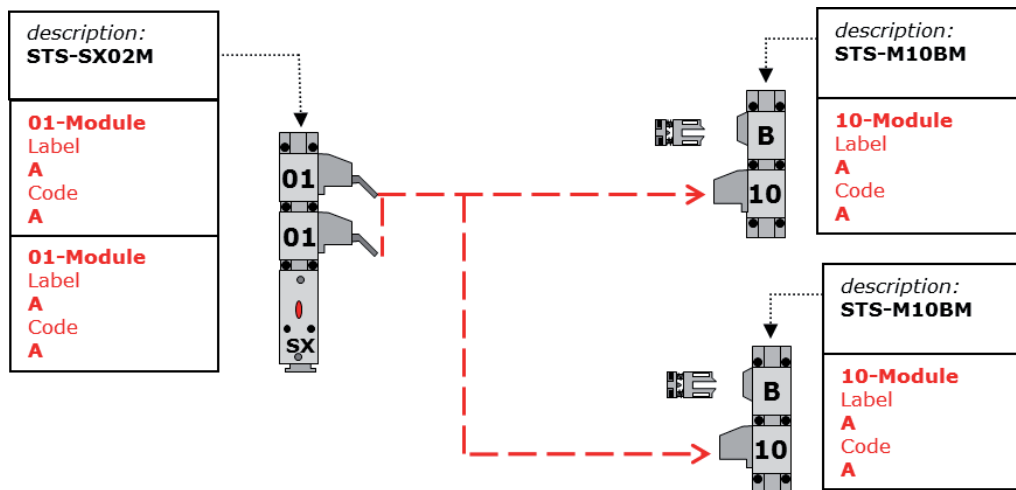

1. Open bayonet ring above SX-module and remove SX-module from 01-module

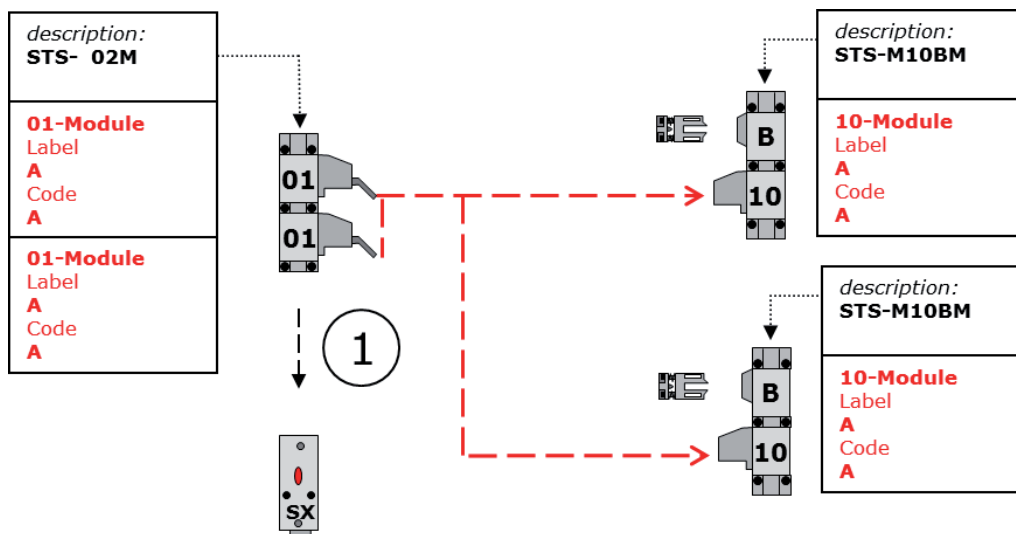

**Modification procedure**

2. Insert B-module to existing 01-modules (code A)
3. Insert bayonet ring to B-module
4. Add SX-module to bayonet ring

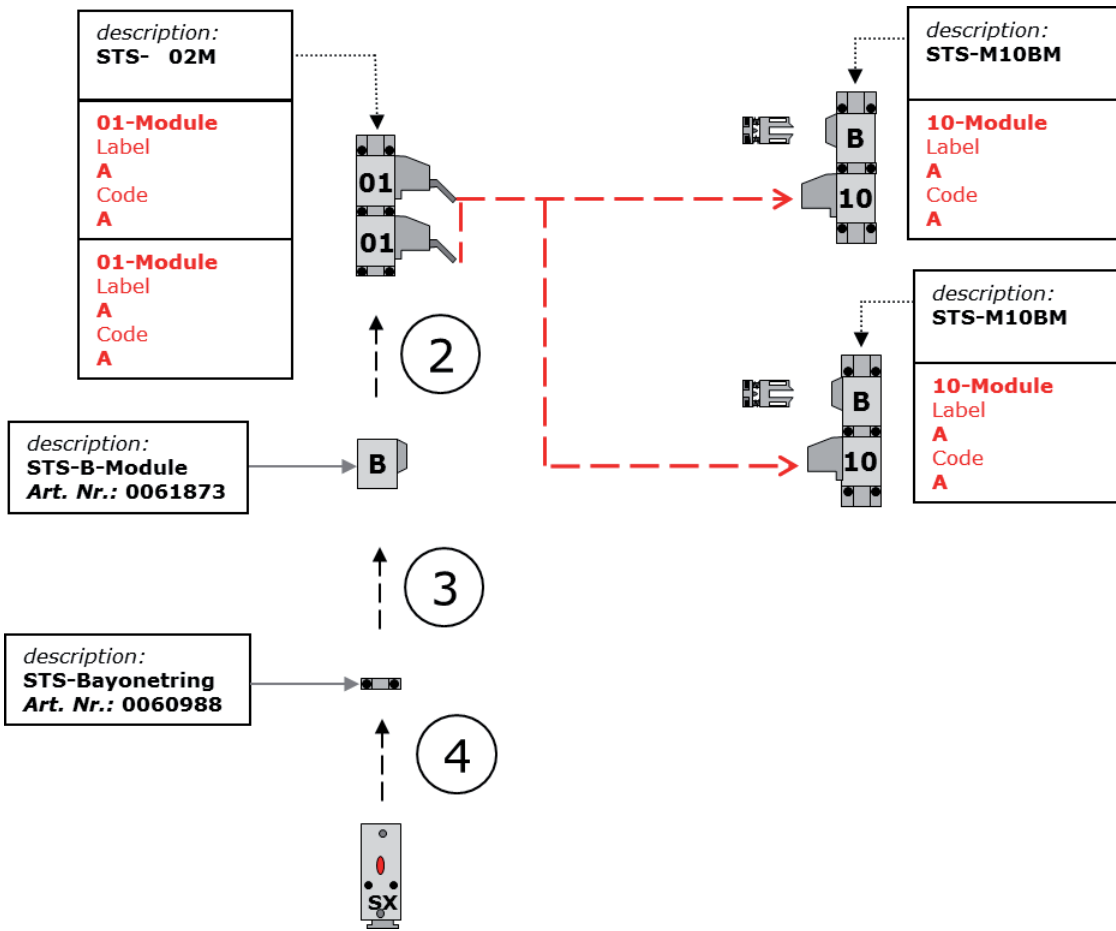

End Situation

