

EUROPEAN UNION DIRECTIVES (CE)



In This Appendix:

European Union (EU) Directives	A-2
Basic EMC Installation Guidelines.....	A-5

European Union (EU) Directives



NOTE: *The information contained in this section is intended as a guideline and is based on our interpretation of the various standards and requirements. Since the actual standards are issued by other parties, and in some cases governmental agencies, the requirements can change over time without advance warning or notice. Changes or additions to the standards can possibly invalidate any part of the information provided in this section.*

This area of certification and approval is absolutely vital to anyone who wants to do business in Europe. One of the key tasks that faced the EU member countries and the European Economic Area (EEA) was the requirement to bring several similar yet distinct standards together into one common standard for all members. The primary purpose of a single standard was to make it easier to sell and transport goods between the various countries and to maintain a safe working and living environment. The Directives that resulted from this merging of standards are now legal requirements for doing business in Europe. Products that meet these Directives are required to have a CE mark to signify compliance.

Member Countries

As of January 1, 2015, the members of the EU are Austria, Belgium, Bulgaria, Croatia, Republic of Cyprus, Czech Republic, Denmark, Estonia, Finland, France, Germany, Greece, Hungary, Ireland, Italy, Latvia, Lithuania, Luxembourg, Malta, Netherlands, Poland, Portugal, Romania, Slovakia, Slovenia, Spain, Sweden, and United Kingdom. Iceland, Liechtenstein, and Norway together with the EU members make up the European Economic Area (EEA) and all are covered by the Directives.

Applicable Directives

There are several Directives that apply to our products. Directives may be amended, or added, as required.

- **Electromagnetic Compatibility Directive (EMC)** — this Directive attempts to ensure that devices, equipment, and systems have the ability to function satisfactorily in an electromagnetic environment without introducing intolerable electromagnetic disturbance to anything in that environment.
- **Machinery Safety Directive** — this Directive covers the safety aspects of the equipment, installation, etc. There are several areas involved, including testing standards covering both electrical noise immunity and noise generation.
- **Low Voltage Directive** — this Directive is also safety related and covers electrical equipment that has voltage ranges of 50–1000 VAC and/or 75–1500 VDC.
- **Battery Directive** — this Directive covers the production, recycling, and disposal of batteries.

Compliance



NOTE: *As of July 22, 2017 ROHS has been added as an additional requirement for CE Compliance per Directive 2011/65/EU. All products bearing the CE mark must be ROHS compliant.*

Certain standards within each Directive already require mandatory compliance. The EMC Directive, which has gained the most attention, became mandatory as of January 1, 1996. The Low Voltage Directive became mandatory as of January 1, 1997.

Ultimately, we are all responsible for our various pieces of the puzzle. As manufacturers, we must test our products and document any test results and/or installation procedures that are necessary to comply with the Directives. As a machine builder, you are responsible for installing the products in a manner which will ensure compliance is maintained. You are also responsible for testing any combinations of products that may (or may not) comply with the Directives when used together. The end user of the products must comply with any Directives that may cover maintenance, disposal, etc., of equipment or various components. *Although we strive to provide the best assistance available, it is impossible for us to test all possible configurations of our products with respect to any specific Directive. Because of this, it is ultimately your responsibility to ensure that your machinery (as a whole) complies with these Directives and to keep up with applicable Directives and/or practices that are required for compliance.*

This then is the product specific standard for CPUs and covers the low voltage and EMC directives as required for European CE certification. This standard has many tests together with test procedures and limits, but also references the below standards for some tests.

IEC 60068	IEC 60417	IEC 60664	IEC 60695	IEC 60707	IEC 60947	IEC 60950	IEC 61000	IEC 61010	
2-1:1990 part 2 Test A	All Parts	1:1992 Part 1	2-1 (all sheets) Part 2	:1999	5-1:1997 Part 5-1	1:2001 Part 1	4-2:1995 Part 4-2	1:2001 Part 1	
2-2:1974 part 2 Test B		3:1992			7-1:2002 Part 7-1		4-3:2002 Part 4-3		
2-6:1995 Part 2: Test Fc							4-4:1995		
2-6:1995 Part 2: Test Fc		CISPR 11:1999					4-5:1995 Part 4-5		
2-14:1984 Part 2 Test N		CISPR 16-1:1999 Part 1					4-6:1996 Part 4-6		
2-27:1987 Part 2 Test Ea		CISPR 16-2:1999 Part 2					4-8:1993 Part 4-8		
2-30:1980 Part 2 Test Db		For undated references, the latest edition of the referenced document (including any amendments) applies.						1-12:1995 Part 4-12	
2-31:1969 Test Ec									
2-32:1975 Part 2 Test Ed									

Productivity1000 systems, manufactured by FACTS Engineering, when properly installed and used, conform to the Electromagnetic Compatibility (EMC), Low Voltage Directive, and Machinery Directive requirements of the following standards:

- **Product Specific Standard for Programmable Controllers**
EN61131-2:2007 EMC, EN61010-2:2010 and EN61010-2-201: 2013 Safety Programmable controllers, equipment requirements and tests.
- **Warning on Electrostatic Discharge (ESD)**
We recommend that all personnel take necessary precautions to avoid the risk of transferring static charges to inside the control cabinet, and clear warnings and instructions should be provided on the cabinet exterior. Such precautions may include the use of earth straps, grounding mats and similar static-control devices, or the powering off of the equipment inside the enclosure before the door is opened.

- **Warning on Radio Interference (RFI)**

This is a class A product. In a domestic environment this product may cause radio interference in which case the user may be required to take adequate measures.

General Safety

- External switches, circuit breaker or external fusing, are required for these devices.
- The switch or circuit breaker should be mounted near the programmable controller equipment.

Special Installation Manual

The installation requirements to comply with the requirements of the Machinery Directive, EMC Directive and Low Voltage Directive are slightly more complex than the normal installation requirements found in the United States. To help with this, we have published a special manual which you can order or download from our website:

- **DA-EU-M** – EU Installation Manual that covers special installation requirements to meet the EU Directive requirements. Refer to this manual for updated information.

Other Sources of Information

Although the EMC Directive gets the most attention, other basic Directives, such as the Machinery Directive and the Low Voltage Directive, also place restrictions on the control panel builder. Because of these additional requirements it is recommended that the following publications be purchased and used as guidelines:

- BSI publication BS TH 42073: November 2000 – covers the safety and electrical aspects of the Machinery Directive
- EN 60204-1:2006 – Safety of Machinery; General electrical requirements for machinery, including Low Voltage and EMC considerations
- IEC 61000-5-2: EMC earthing and cabling requirements
- IEC 61000-5-1: EMC general considerations

It may be possible for you to obtain this information locally; however, the official source of applicable Directives and related standards is:

Publications Office
2, rue Mercier
2985 Luxembourg
LUXEMBOURG

Quickest contact is via the web at:

<http://ec.europa.eu/growth/single-market/european-standards/harmonised-standards>.

Another source is the British Standards Institution at:

British Standards Institution – Sales Department, Linford Wood:
Milton Keynes, MK14 6LE, United Kingdom.

The quickest contact is via the web at www.bsigroup.com

Basic EMC Installation Guidelines

Enclosures

The following diagram illustrates good engineering practices supporting the requirements of the Machinery and Low Voltage Directives. House all control equipment in an industry standard lockable steel enclosure and use metallic conduit for wire runs and cables.

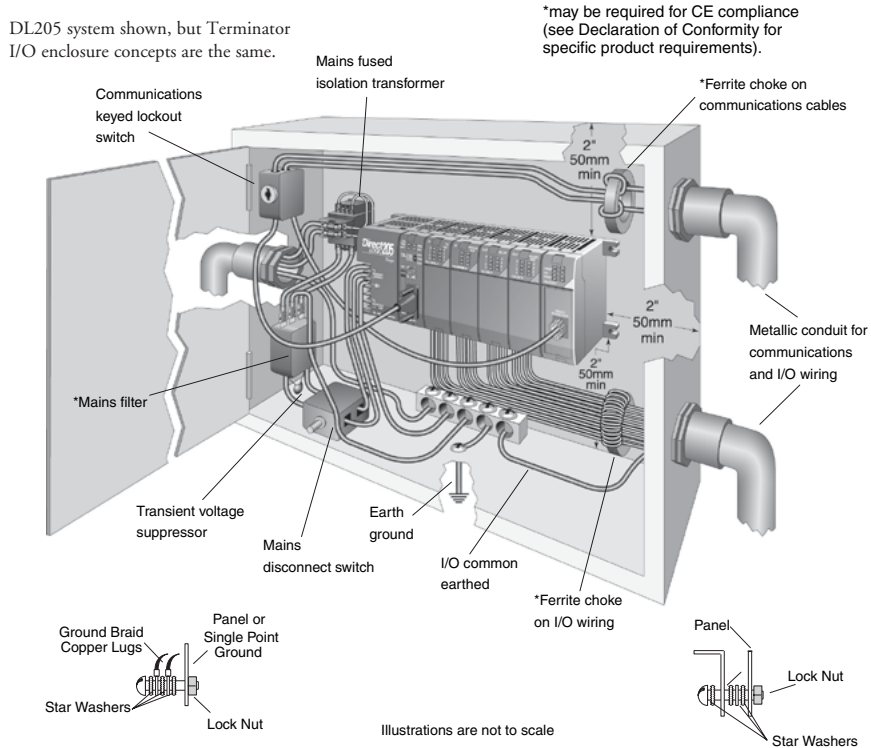

Electrostatic Discharge (ESD)

We specify in all declarations of conformity that our products are installed inside an industrial enclosure using metallic conduit for external wire runs; therefore, we test the products in a typical enclosure. However, we would like to point out that although our products operate normally in the presence of ESD, this is only the case when mounted within an enclosed industrial control cabinet. When the cabinet is open during installation or maintenance, the equipment and or programs may be at risk of damage from ESD carried by personnel.

We therefore recommend that all personnel take necessary precautions to avoid the risk of transferring static electricity to components inside the control cabinet. If necessary, clear warnings and instructions should be provided on the cabinet exterior, such as recommending the use of earth straps of similar devices, or the powering off of equipment inside the enclosure.

AC Mains Filters

The DL305 AC powered base power supplies require extra mains filtering to comply with the EMC Directive on conducted RF emissions. All PLC and Terminator I/O equipment has been tested with filters from Schaffner, which reduce emissions levels if the filters are properly grounded (earth ground). A filter with a current rating suitable to supply all PLC or Terminator I/O power supplies and AC input modules should be selected. We suggest the FN2080 for DL305 systems.

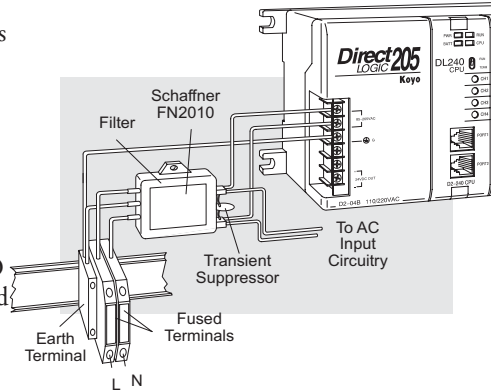

NOTE: Very few mains filters can reduce problem emissions to negligible levels. In some cases, filters may increase conducted emissions if not properly matched to the problem emissions.

Suppression and Fusing

In order to comply with the fire risk requirements of the Low Voltage and Machinery Directive electrical standards EN 61010–1, and EN 60204–1, by limiting the power into “unlimited” mains circuits with power leads reversed, it is necessary to fuse both AC and DC supply inputs. You should also install a transient suppressor across the power input connections of the PLC or Terminator I/O. Choose a suppressor such as a metal oxide varistor, with a rating of 275 VAC working voltage for 230 V nominal supplies (150 VAC working voltage for 115 V supplies) and high energy capacity (eg. 140 joules).

Transient suppressors must be protected by fuses and the capacity of the transient suppressor must be greater than the blow characteristics of the fuses or circuit breakers to avoid a fire risk. A recommended AC supply input arrangement for Koyo PLCs and Terminator I/O is to use twin 3 amp TT fused terminals with fuse blown indication, such as DINnectors DN–F10L terminals, or twin circuit breakers, wired to a Schaffner FN2010 filter or equivalent, with high energy transient suppressor soldered directly across the output terminals of the filter. PLC and Terminator I/O system inputs should also be protected from voltage impulses by deriving their power from the same fused, filtered, and surge-suppressed supply.

Internal Enclosure Grounding

A heavy-duty star earth terminal block should be provided in every cubicle for the connection of all earth ground straps, protective earth ground connections, mains filter earth ground wires, and mechanical assembly earth ground connections. This should be installed to comply with safety and EMC requirements, local standards, and the requirements found in IEC 1000–5–2. The Machinery Directive also requires that the common terminals of PLC or Terminator I/O input modules, and common supply side of loads driven from PLC or Terminator I/O output modules should be connected to the protective earth ground terminal.

Equi-potential Grounding

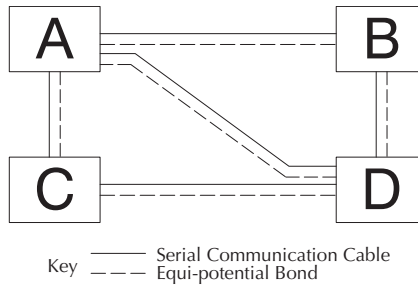

communications with the primary PLC or Terminator I/O system enclosure. An equi-potential bond wire must be provided alongside all serial communications cables, and to any separate items of the plant which contain I/O devices connected to the PLC or Terminator I/O system. The diagram shows an example of four physical locations connected by a communications cable.

Communications and Shielded Cables

Good quality 24 AWG minimum twisted-pair shielded cables, with overall foil and braid shields are recommended for analog cabling and communications cabling outside of the PLC or Terminator I/O enclosure. To date it has been a common practice to only provide an earth ground for one end of the cable shield in order to minimize the risk of noise caused by earth ground loop currents between apparatus. The procedure of only grounding one end, which primarily originated as a result of trying to reduce hum in audio systems, is no longer

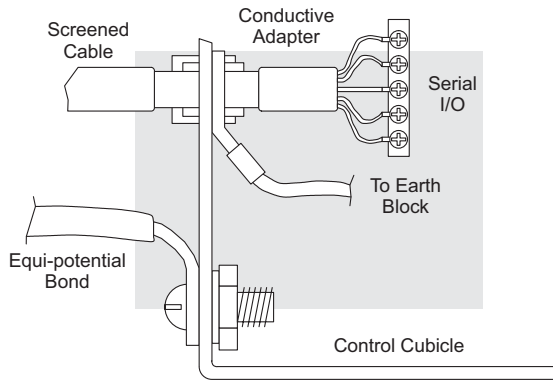

The recommendation is to use shielded cables as electrostatic “pipes” between apparatus and systems, and to run heavy gauge equi-potential bond wires alongside all shielded cables. When a shielded cable runs through the metallic wall of an enclosure or machine, it is recommended in IEC 1000–5–2 that the shield should be connected over its full perimeter to the wall, preferably using a conducting adapter, and not via a pigtail wire connection to an earth ground bolt. Shields must be connected to every enclosure wall or machine cover that they pass through.

Analog and RS-232C Cables

Providing an earth ground for both ends of the shield for analog circuits provides the perfect electrical environment for the twisted pair cable as the loop consists of signal and return, in a perfectly balanced circuit arrangement, with connection to the common of the input circuitry made at the module terminals. RS-232C cables are handled in the same way.

Multidrop Cables

RS-422 twin twisted pair, and RS-485 single twisted pair cables also require a 0 V link, which has often been provided in the past by the cable shield. It is now recommended that you use triple twisted pair cabling for RS-422 links, and twin twisted pair cable for RS-485 links. This is because the extra pair can be used as the 0V inter-system link. With loop DC power supplies earth grounded in both systems, earth loops are created in this manner via the inter-system 0v link. The installation guides encourage earth loops, which are maintained at a low impedance by using heavy equi-potential bond wires. **To account for non-European installations using single-end earth grounds, and sites with far from ideal earth ground characteristics, we recommend the addition of 100 ohm resistors at each 0 V link connection in network and communications cables.**

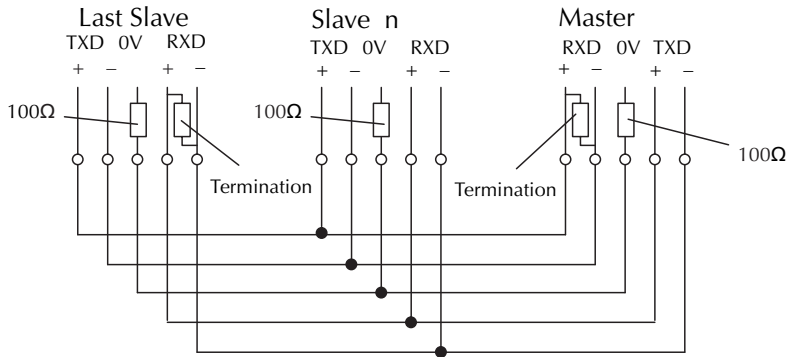

Shielded Cables within Enclosures

When you run cables between PLC or Terminator I/O items within an enclosure which also contains susceptible electronic equipment from other manufacturers, remember that these cables may be a source of RF emissions. There are ways to minimize this risk. Standard data cables connecting PLCs, Terminator I/O and/or operator interfaces should be routed well away from other equipment and their associated cabling. You can make special serial cables where the cable shield is connected to the enclosure's earth ground at both ends, the same way as external cables are connected.

Analog Modules and RF Interference

The readings from all analog modules will be affected by the use of devices that exhibit high field strengths, such as mobile phones and motor drives.

All Automationdirect products are tested to withstand field strength levels up to 10 V/m, which is the maximum required by the relevant EU standards. While all products pass this test, analog modules will typically exhibit deviations of their readings. This is quite normal, however, systems designers should be aware of this and plan accordingly.

When assembling a control system using analog modules, these issues must be adhered to and should be integrated into the system design. This is the responsibility of the system builder/commissioner.

Network Isolation

For safety reasons, it is a specific requirement of the Machinery Directive that a keyswitch must be provided that isolates any network input signal during maintenance, so that remote commands cannot be received that could result in the operation of the machinery. **The FA-ISONET does not have a keyswitch!** Use a keylock and switch on your enclosure which when open removes power from the FA-ISONET. To avoid the introduction of noise into the system, any keyswitch assembly should be housed in its own earth grounded steel box and the integrity of the shielded cable must be maintained.

Again, for further information on EU directives we recommend that you get a copy of our EU Installation Manual (DA-EU-M). Also, if you are connected to the World Wide Web, you can check the EU commission's official site at: http://ec.europa.eu/index_en.htm

DC Powered Versions

Due to slightly higher emissions radiated by the DC powered versions of the Terminator I/O system, and the differing emissions performance for different DC supply voltages, the following stipulations must be met:

- The Terminator I/O system must be housed within a metallic enclosure with a minimum amount of orifices.
- I/O and communications cabling exiting the cabinet must be contained within metallic conduit/trunking.

Items Specific to the Terminator I/O System

- The rating between all circuits in this product are rated as **basic insulation only**, as appropriate for single fault conditions.
- There is no isolation offered between the PLC or Terminator I/O system and the analog inputs of this product.
- It is the responsibility of the system designer to earth one side of all control and power circuits, and to earth the braid of screened cables.
- This equipment must be properly installed while adhering to the guidelines of the in house installation manual DA-EU-M, and the installation standards IEC 1000-5-1, IEC 1000-5-2 and IEC 1131-4.
- It is a requirement that all PLC or Terminator I/O equipment must be housed in a protective steel enclosure, which limits access to operators by a lock and power breaker. If access is required by operators or untrained personnel, the equipment must be installed inside an internal cover or secondary enclosure.
- It should be noted that the safety requirements of the machinery directive standard EN60204-1 state that all equipment power circuits must be wired through isolation transformers or isolating power supplies, and that one side of all AC and DC control circuits must be earthed.
- Both power input connections to the PLC or Terminator I/O must be separately fused using 3 amp T type anti-surge fuses, and a transient suppressor fitted to limit supply overvoltages.
- Please be aware of notification within the documentation that if the equipment is used in a manner not specified by the manufacturer the protection provided by the equipment may be impaired.
- Input power cables must be externally fused and have an externally mounted switch or circuit breaker, preferably mounted near the Terminator I/O system.
- When needed, carefully clean the outside plastic case of Terminator I/O components using a dry cloth.
- Only use replacement parts supplied by **AutomationDirect** or its agents.
- Cables, whether shielded or not, **MUST** be enclosed within earthed metal conduit or other metallic trunking when outside the Terminator I/O enclosure.
- This is a Class A product and it may cause radio interference in certain environments. The user may need to provide shielding, or other measures to eliminate the interference.