



The most practical automation products at the industry's lowest prices delivered by 11 a.m.

Data Sheet: T1F-08AD-2-DS Rev B

Terminator I/O

T1F-08AD-2 Analog Input Module (use base T1K-08B or T1K-08B-1)

Insert Module into Base

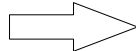

Install Assembly on DIN Rail

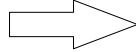

Slide Assembly into Position

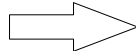

← Module Specifications

← Wiring and Dimensions

WARNING: To minimize the risk of potential safety problems, you should follow all applicable local and national codes that regulate the installation and operation of your equipment. These codes vary from area to area and it is your responsibility to determine which codes should be followed, and to verify that the equipment, installation, and operation are in compliance with the latest revision of these codes.

Equipment damage or serious injury to personnel can result from the failure to follow all applicable codes and standards. We do not guarantee the products described in this publication are suitable for your particular application, nor do we assume any responsibility for your product design, installation, or operation.

If you have any questions concerning the installation or operation of this equipment, or if you need additional information, please call us at 770-844-4200.

This publication is based on information that was available at the time it was printed. At **Automationdirect.com**™ we constantly strive to improve our products and services, so we reserve the right to make changes to the products and/or publications at any time without notice and without any obligation. This publication may also discuss features that may not be available in certain revisions of the product.

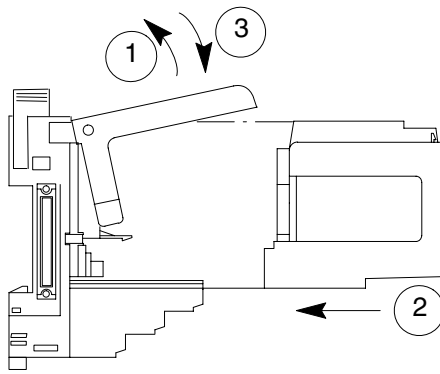

Insert Module into Base

1. Pull base arm back to allow space for module to enter base
2. Align module slides with base track
3. Press module firmly into base

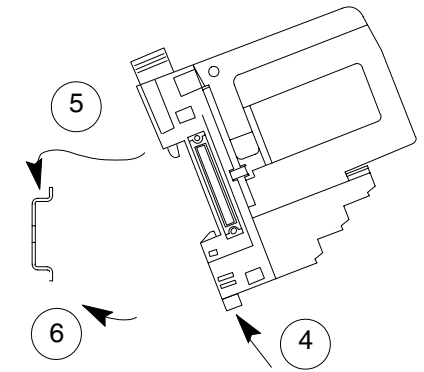

Install Assembly on DIN Rail

4. Make sure the locking tab is in the latched (in) position
5. Hook upper tab over upper flange of DIN rail
6. Tilt assembly toward DIN rail until module snaps securely to DIN rail

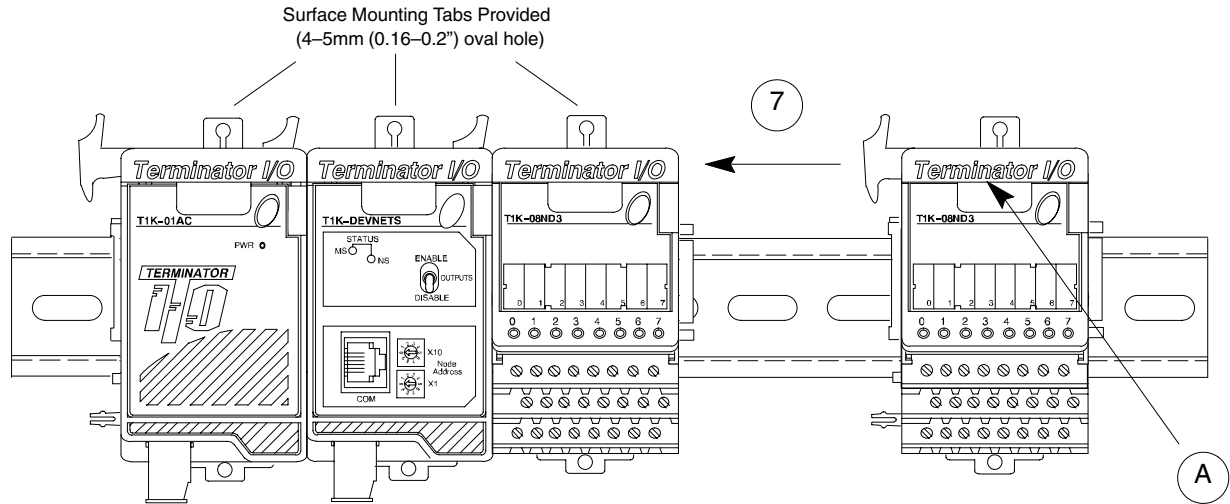

Slide Assembly into Position on DIN Rail

7. Slide the module assembly on the DIN rail until the clip arm attaches securely to the adjacent module.

A. To remove the module from the base, lift the center of the base arm slightly outward and upward to release the module. Lifting the base arm further will eject the module.
B. To remove the module assembly from the DIN rail, lift the clip arm up and slide the module assembly away from the adjacent module. Use a small screwdriver to pull the locking tab to the down position.

Specifications

T1F-08AD-2 8 Channel Voltage Analog Input

Number of Channels	8, single ended (1 common)
Input Ranges	0-5V, 0-10V, +/- 5V, +/- 10V
Resolution	14 bit (13 bit plus sign bit)
-3dB Frequency Response Sampling	Normal: 8ch enabled 30Hz Fast: 8/4/1ch 100/1000/2000Hz
Input Resistance	200K ohm min.
Absolute Max. Ratings	Fault Protected Input 130V(rms) or 100VDC
Conversion Time (Default: Normal Mode)	Normal Mode: 5ms per channel *Fast Mode: 0.5ms per channel
Linearity Error	+ / - 2 count max.
Input Stability (Default: Normal Mode)	Normal Mode: + / - 1 count *Fast Mode: + / - 5 counts
Calibration Full Scale Error	8 counts max.
Calibration Offset Error	2 counts max.
Max. Full Scale Inaccuracy (% of full scale); all errors included	0.08% @ 25°C 0.26% @ 60°C
Master Update Rate	8 channels per scan max.
Input Points Required	256 discrete pts. or 8 dwords (d (double) word = 32 bit word) Network Interface dependent
Base Power Required	75mA @ 5VDC
External Power Supply	18-30 VDC, 50mA, class 2
Operating Temperature	0 to 60°C (32 to 140°F)
Storage Temperature	-20 to 70°C (-4 to 158°F)
Accuracy vs. Temperature	+ / - 50 ppm / °C max. full scale
Relative Humidity	5 to 95% (non-condensing)
Environmental Air	No corrosive gases permitted
Vibration	MIL STD 810C 514.2
Shock	MIL STD 810C 516.2
Noise Immunity	NEMA ICS3-304
weight	136g

Input Range Resolution:

0 - 5V	0 - 4095 counts
0 - 10V	0 - 8191 counts
+ / - 5V	-4095 to 4095 counts
+ / - 10V	-8192 to 8191 counts

Wiring & Dimensions

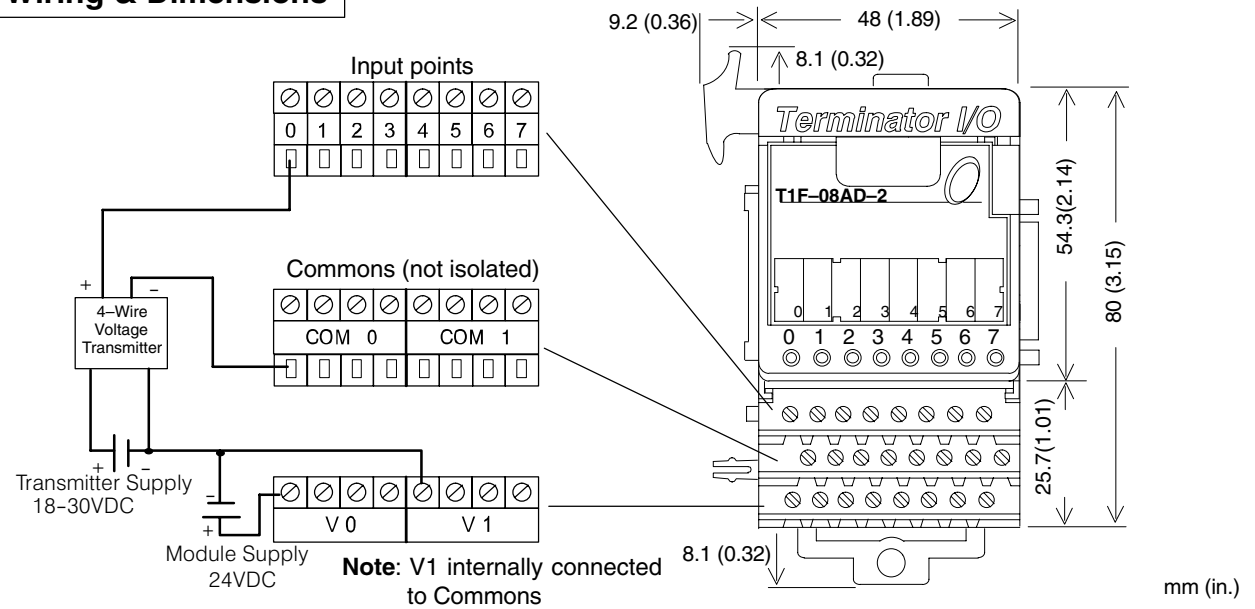

NOTES:

- 1: Shields should be grounded at the signal source.
- 2: Unused inputs should be connected to Common (0VDC).
- 3: More than one external power supply can be used, provided all the power supply commons are connected.

Input Signal Ranges

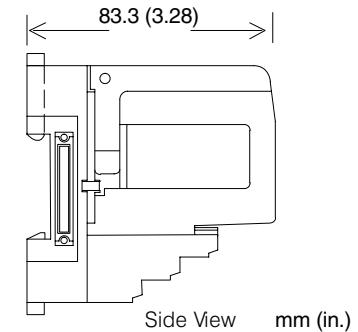
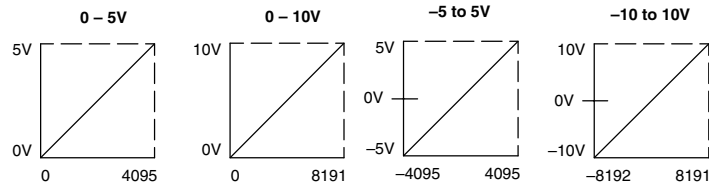

Equivalent Input Circuit

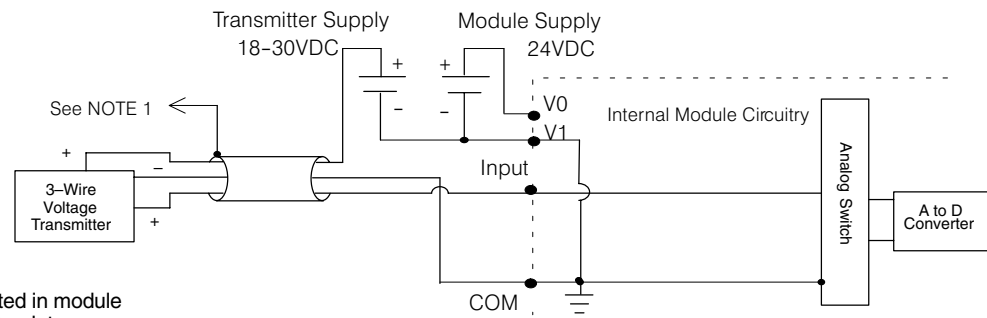

*Fast mode supported in module hardware version B or later.