



SureServo2 460VAC DRIVES QUICK START GUIDE

High Resolution Communication Type AC Servo Drive

(1) GENERAL PRECAUTIONS

Thank you for purchasing this product. This instruction sheet provides information about the SV2A series servo drives and servo motors. Before using this product, read this instruction sheet carefully to ensure the correct use of the product. Keep this sheet handy for quick reference whenever needed. Before you begin, please note the following:

- The installation location must be free of vapor, corrosive and flammable gas.
- When wiring, do not connect the three-phase power supply to the motor UVW connectors. Incorrect wiring may cause damage to the servo drive.
- Ensure this product is correctly grounded. All grounding and circuit protection methods must comply with all local standards/regulations and the national electrical standard (refer to NFPA 70: National Electrical Code, 2020 Ed.).
- Do not disassemble the servo drive and motor or change the wiring when the power is on.
- Ensure you can activate the STO circuit before the servo drive is connected to power and put into operation.
- Do not touch the heat sink of the servo drive when it is connected to power and operating to avoid scalding.

For more information about the SV2A series servo drives and servo motors, refer to the user manual. Contact our Technical Support Department if you encounter any problems.

(1) PRÉCAUTIONS GÉNÉRALES

Merci d'avoir acheté ce produit. Cette feuille d'instructions fournit des renseignements sur les entraînements et les moteurs asservis de la série SV2A. Avant d'utiliser ce produit, lisez attentivement ce feuillet d'instructions pour vous assurer d'utiliser correctement le produit. Gardez cette feuille à portée de la main pour consultation rapide, au besoin. Avant de terminer la lecture de cette feuille, suivez les instructions suivantes :

- L'emplacement de l'installation doit être exempt de vapeurs ou de gaz corrosifs ou inflammables.
- Lors du câblage, ne connectez pas l'alimentation triphasée aux connecteurs UVW du moteur. Un mauvais câblage peut endommager l'entraînement asservi.
- Assurez-vous que ce produit est correctement mis à la terre. La méthode de mise à la terre et protection des circuits doit être conforme à la norme électrique nationale (voir NFPA 70 : National Electrical Code, édition 2020).
- Ne démontez pas l'entraînement ou le moteur asservi et ne modifiez pas le câblage lorsque l'alimentation est sous tension.
- Assurez-vous de pouvoir activer l'arrêt d'urgence avant que l'entraînement asservi ne soit connecté à l'alimentation et mis en marche.
- Ne touchez pas le dissipateur thermique de l'entraînement asservi lorsqu'il est branché à l'alimentation et qu'il fonctionne pour éviter l'échaudement.

Pour en savoir plus sur les entraînements et les moteurs asservis de la série SV2A, consultez le manuel d'utilisation. En cas de problème, communiquez avec notre Centre de service à la clientèle.

(2) SAFETY PRECAUTIONS

The SV2A series is a high-resolution servo drive used in industrial applications. Install it in a shielded control box before operation. Install the servo drives, wires, and motors in an environment that complies with the minimum requirement of UL50 Type 1 or NEMA 250 Type 1.

Pay special attention to the following safety precautions during inspection, installation, wiring, operation, maintenance, and examination.

Inspection	
	Follow the instructions when using the servo drive and servo motor to avoid risk of fire or malfunction.
Installation	
	Do not expose the product to an environment containing vapor, corrosive gas, flammable gas, or other foreign matter to reduce the risk of electric shock or fire.
Wiring	
	<ul style="list-style-type: none"> • Connect the ground terminals to a Class 3 ground system. Ground resistance should not exceed 100Ω. Improper grounding may result in electric shock or fire. • Do not connect three-phase power to motor output terminals U, V and W. Doing so may cause personnel injury or fire. • Tighten the screws on the power and motor output terminals to ensure good connections and avoid risk of fire. • When wiring, refer to the descriptions of the wire selection to prevent any danger.
Operation	
	<ul style="list-style-type: none"> • Before operating the machine, change the parameter settings according to the application. If the parameters are not adjusted to the correct values, it may lead to machine malfunctions or unpredictable operation. • Before the machine starts to operate, make sure you can activate the STO circuit at any time
	Do not touch any rotating motor parts during operation, or it may result in personnel injury.
	<ul style="list-style-type: none"> • During the first test run, remove all units (including the couplings and belts) and operate the machine without any load to avoid accidents. • Improper machine operation after the servo motor connects may damage the machine and lead to personnel injury. • In order to prevent danger, make sure the servo motor can operate normally without load. Then try operating the motor with load. • Do not touch the heat sink of the servo drive during operation to avoid scalding.

Maintenance and Inspection	
	<ul style="list-style-type: none"> • Do not touch the internal parts of the servo drive or servo motor, as that may cause electric shock. • Do not disassemble the servo drive panel when the power is on, as that may cause electric shock. • Do not touch the wiring terminals within 10 minutes after turning off the power, as doing so creates a risk of electric shock from residual voltage. • Do not disassemble the servo motor, as that may cause electric shock or personnel injury. • Do not change the wiring when the power is on, as that may cause electric shock or personnel injury. • Only qualified electricians can install, wire, repair, and maintain the servo drive and servo motor. • Make sure that the "CHARGE" indicator is off before performing maintenance, inspection, or repair.
Main Circuit Wiring	
	Do not repeatedly turn the power on and off. If power cycling is needed, wait one minute between cycles.
	<ul style="list-style-type: none"> • Do not put the power cable and signal cable in the same channel or bond them together. Separate the power cable and signal cable by at least 30cm (11.8 in.). • Use stranded wires and multi-core shielded-pair wires for the encoder cables. The maximum length should be no more than 20m (65.6 ft). • High voltage may remain in the servo drive after the power is turned off. Wait for 10 minutes before touching the terminals and make sure the "CHARGE" indicator is off before performing inspection.
Terminal Wiring of the Main Circuit	
	<ul style="list-style-type: none"> • When wiring, remove the terminal blocks from the servo drive. • Insert only one electric wire per terminal socket. • When inserting the electric wires, do not short-circuit the core wire with adjacent wires. • Before applying power, inspect and make sure the wiring is correct.

(2) PRÉCAUTIONS DE SÉCURITÉ

Comme la série SV2A est un entraînement asservi à haute résolution de type ouvert utilisé dans les applications industrielles, installez-le dans une boîte de contrôle blindée. Installez les entraînements asservis, les fils et les moteurs dans un environnement conforme aux exigences minimales des normes UL50 Type 1 ou NEMA 250 Type 1.

Portez une attention particulière aux précautions de sécurité suivantes pendant l'inspection, l'installation, le câblage, l'utilisation, l'entretien et l'examen.

Inspection	
	Suivez les instructions lors de l'utilisation de l'entraînement et du moteur asservi afin d'éviter un incendie ou le dysfonctionnement.
Installation	
	N'exposez pas le produit à un environnement contenant des vapeurs, du gaz corrosif ou inflammable ou d'autres corps étrangers afin de réduire le risque de choc électrique ou d'incendie.
Câblage	
	<ul style="list-style-type: none"> • Raccordez les bornes de mise à la terre à un système de mise à la terre de classe 3. La résistance de terre ne doit pas dépasser 100 Ω. Une mise à la terre inadéquate peut provoquer un choc électrique ou un incendie. • Ne connectez pas l'alimentation triphasée aux bornes de sortie du moteur U, V et W afin d'éviter les blessures corporelles ou un incendie. • Serrez les vis des bornes d'alimentation et de sortie du moteur afin d'éviter un incendie. • Lors du câblage, reportez-vous aux descriptions de sélection des fils afin d'éviter tout danger.
Utilisation	
	<ul style="list-style-type: none"> • Avant d'utiliser la machine, modifiez les paramètres en fonction de l'application. Si les paramètres ne sont pas réglés aux valeurs correctes, cela peut entraîner un dysfonctionnement de la machine ou le fonctionnement incontrôlé. • Avant de mettre la machine en marche, assurez-vous de pouvoir activer l'arrêt d'urgence en tout temps.
	Ne touchez aucune pièce rotative du moteur pendant qu'il fonctionne, car cela peut entraîner des blessures corporelles.
	<ul style="list-style-type: none"> • Afin d'éviter les accidents lors du premier essai de fonctionnement, retirez tous les accessoires, y compris les accouplements et les courroies, afin que la machine fonctionne à vide. • Si vous ne faites pas fonctionner la machine correctement après la connexion du moteur asservi à la machine, cela pourrait causer des dommages à la machine et des blessures au personnel. • Afin de prévenir le danger, assurez-vous que le moteur asservi fonctionne normalement à vide. Essayez ensuite de faire fonctionner le moteur sous charge. • Ne touchez pas le dissipateur thermique de l'entraînement asservi lorsqu'il fonctionne pour éviter l'échaudement.
Entretien et inspection	
	<ul style="list-style-type: none"> • Ne touchez pas les pièces internes de l'entraînement et du moteur asservis, car cela peut causer un choc électrique. • Ne démontez pas le panneau de l'entraînement asservi lorsque l'alimentation est sous tension, car cela peut provoquer un choc électrique. • Ne touchez pas les bornes de câblage dans les 10 minutes après avoir coupé l'alimentation, car la tension résiduelle peut provoquer un choc électrique. • Ne démontez pas le moteur asservi, car il peut causer un choc électrique ou des blessures corporelles. • Ne modifiez pas le câblage lorsque l'alimentation est sous tension, car elle peut causer un choc électrique ou des blessures corporelles. • Seuls les électriciens qualifiés peuvent installer, raccorder, réparer et entretenir l'entraînement et le moteur asservis. • Assurez-vous que l'indicateur « CHARGE » est éteint avant d'effectuer l'entretien, l'inspection ou la réparation.
Câblage du circuit principal	
	Ne mettez pas l'appareil sous tension et hors tension à plusieurs reprises. Si une mise sous tension et hors tension continue est nécessaire, attendez un intervalle d'une minute.
	<ul style="list-style-type: none"> • Ne mettez pas le câble d'alimentation et le câble de signal dans le même conduit et ne les liez pas. Séparez le câble d'alimentation et le câble de signal d'au moins 30 centimètres (11,8 pouces). • Utilisez des paires de fils torsadés et de fils multicœurs blindés pour les câbles de l'encodeur. La longueur maximale ne doit pas dépasser 20 mètres (65,6 pieds). • Une tension élevée peut rester dans l'entraînement asservi une fois l'alimentation désactivée. Attendez 10 minutes avant de toucher les bornes et assurez-vous que l'indicateur « CHARGE » est éteint avant d'effectuer l'inspection.
Câblage des bornes du circuit principal	
	<ul style="list-style-type: none"> • Lors du câblage, retirez les borniers de l'entraînement asservi. • Insérez un seul fil électrique par douille de borne. • Lors de l'insertion des fils électriques, ne court-circuitez pas le fil central avec des fils adjacents. • Avant d'appliquer l'alimentation, inspectez le câblage et assurez-vous qu'il est correct.

(3) WIRE SELECTION

The following wire sizes and circuit protection (High-Speed J fuses or circuit breakers) are recommended for connection to SV2A drives. Standard 60 ° C copper wire values used for calculations. See the SureServo2 User Manual for more details.

Always follow all local and national electrical codes when selecting wiring and circuit protection.

Servo Drive Model	24VDC, 0V		R, S, T		P1, P2, ⊖, P3, C	UVW (motor)	
	Wire Size mm ² (AWG)	Fusing	Voltage Level	Wire Size mm ² (AWG)	Circuit Protection (A)	Wire Size mm ² (AWG)	Wire Size mm ² (AWG)
SV2A-4040	0.82 (18)	3A	380-480 VAC 3-phase	0.82 (18)	3	2.1 (14)	0.82 (18)
SV2A-4075				0.82 (18)	5	3.3 (12)	
SV2A-4150				0.82 (18)	7	5.3 (10)	1.3 (16)
SV2A-4200				1.3 (16)	10		
SV2A-4300		2.1 (14)		15	8.4 (8)	2.1 (14)	
SV2A-4550		5.3 (10)*		25			13.3 (6)
SV2A-4750		8.4 (8)*		35	21.2 (4)	8.4 (8)	
SV2A-4F00		13.3 (6)*		50			

* Ring lugs recommended

Note: Wire size (and circuit protection) limited by physical size of connectors. See the User Manual for details on higher amperages.

Servo Drive Model	24VDC, 0V, R, S, T, P1, P2, P3, C, ⊖ Locking Torque (kgf·cm)	U, V, W Locking Torque (kgf·cm)
SV2A-4200	12	12
SV2A-4300		
SV2A-4550		
SV2A-4750		
SV2A-4F00		

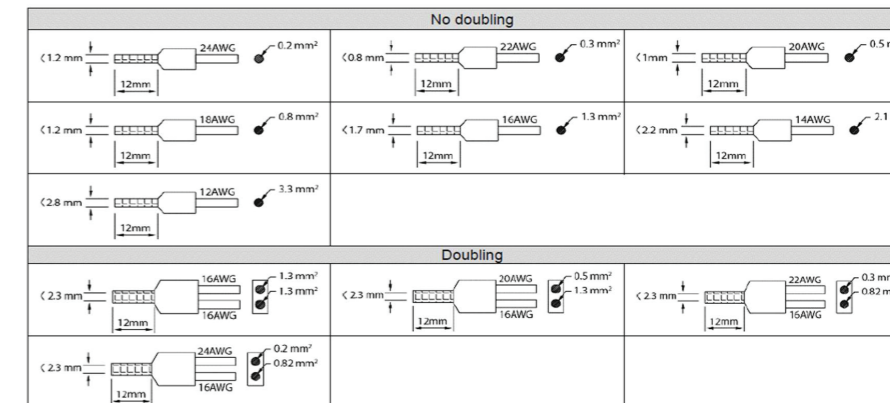

Servo Drive	Encoder Wiring - Wire Diameter mm ² (AWG)			
	Size	Number	Specification	Standard Length
SV2A	L = 3-20 m: 0.324 mm ² -2C (22AWG-2C) + 0.205 mm ² -2P (24AWG-2P)	2C + 2P	L = 3 - 20 m (UL2464)	L = 3 - 20 m (9.84 - 65.6 ft)

Note: When the encoder cable length is 3 - 20 m, AWG22 is +5V and grounded, and AWG24 is the signal cable.

(4) AMBIENT INSTALLATION CONDITIONS

Ambient environmental conditions for installing and operating the SV2A servo drive	
	The environment should be free of devices that generate excessive heat; no water, vapor, dust, or oily dust; no corrosive and flammable gas or liquids; no airborne dust or metal particles; the environment should be solid without vibration and free from electromagnetic noise.
Ambient environmental conditions when operating the servo motor	
	Operating environment ambient temperature should be between 0°C (32°F) and 40°C (104°F). The environment should be free of devices that generate excessive heat; no water, vapor, dust, or oily dust; no corrosive and flammable gas or liquids; no airborne dust or metal particles.

(4) CONDITIONS AMBIANTES D'INSTALLATION

Conditions ambiantes d'installation et d'utilisation de l'entraînement asservi SV2A	
	L'environnement doit être exempt d'appareils qui génèrent une chaleur excessive; pas d'eau, de vapeurs, de poussière et de poussière huileuse; aucun gaz ou liquide corrosif et inflammable; pas de poussière ou de particules métalliques en suspension dans l'air; l'environnement doit être exempt de vibrations et de bruit électromagnétique.
Conditions ambiantes de fonctionnement du moteur asservi	
	La température ambiante de l'environnement de fonctionnement doit être entre 0 °C (32 °F) et 40 °C (104 °F). L'environnement doit être exempt d'appareils qui génèrent une chaleur excessive; pas d'eau, de vapeurs, de poussière et de poussière huileuse; aucun gaz ou liquide corrosif et inflammable; pas de poussière ou de particules métalliques en suspension dans l'air.

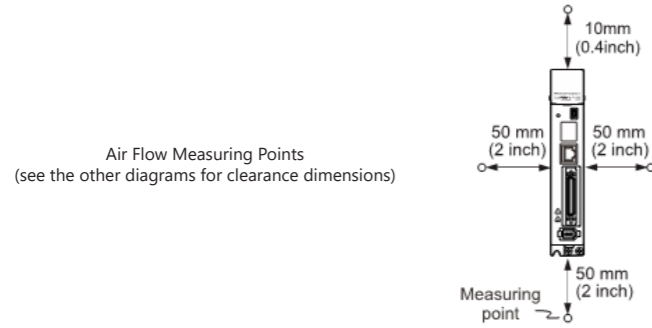

When operating the servo drive, the ambient environmental temperature should be between 0°C (32°F) and 55°C (131°F). If the temperature is over 45°C (113°F), place the product in a well-ventilated environment. During long-term operation, the suggested temperature of the operating environment should be under 45°C (113°F) to ensure the servo drive's performance. When operating the 3kW models in an ambient temperature between 50°C (122°F) and 55°C (131°F), reduce the maximum load to 80%. Keep a clearance of at least 50mm above the drives and keep the speed of air flow above 1 m/s. If the product is installed in an electrical cabinet, make sure the size of the cabinet and its ventilation condition can prevent the internal electrical devices from overheating. Also, check if the vibration of the machine affects the electrical devices in the electrical cabinet.

La température ambiante de l'environnement de fonctionnement de l'entraînement asservi doit être entre 0 °C (32 °F) et 55 °C (131 °F). Si la température est supérieure à 45 °C (113 °F), placez le produit dans un environnement bien ventilé. Pour le fonctionnement à long terme, la température suggérée de l'environnement d'opération doit être inférieure à 45 °C (113 °F) afin d'assurer le bon rendement de l'entraînement asservi. Si le produit est installé dans un tableau de distribution, assurez-vous que la taille du tableau de distribution et la ventilation peuvent empêcher la surchauffe des dispositifs électriques internes. Vérifiez également si la vibration de la machine affecte les dispositifs électriques du tableau de distribution.

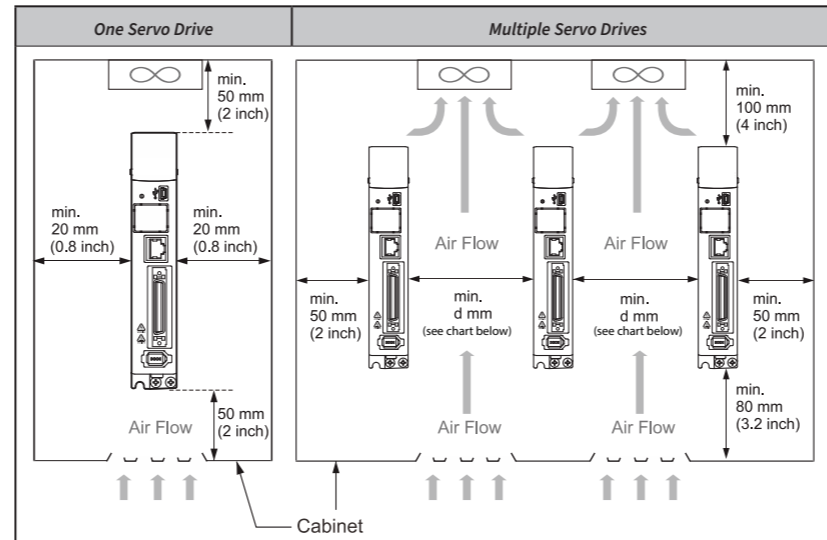

Note: The above diagrams are not accurately scaled. Refer to the diagram annotations.

(5) INSTALLATION DIRECTION AND SPACE

- Precautions:
- Incorrect installation direction may result in malfunction.
 - For better ventilation and cooling, allow sufficient clearance space between the AC servo drive and the adjacent objects and the wall, or overheating may result in malfunction of the machine.
 - Do not block the ventilation holes of the AC servo drive, and do not mount it in the incorrect direction, or it may result in malfunction of the machine.

(5) ORIENTATION ET ESPACE REQUIS POUR L'INSTALLATION

- Precautions:
- Une mauvaise orientation d'installation peut entraîner un dysfonctionnement.
 - Pour une meilleure ventilation et un meilleur refroidissement, prévoyez un dégagement suffisant entre l'entraînement asservi c.a., les objets adjacents et le mur, sinon la surchauffe peut entraîner un dysfonctionnement de la machine.
 - Ne bloquez pas les orifices d'aération de l'entraînement asservi c.a. et ne le fixez pas dans la mauvaise direction, ou cela pourrait entraîner un dysfonctionnement de la machine.

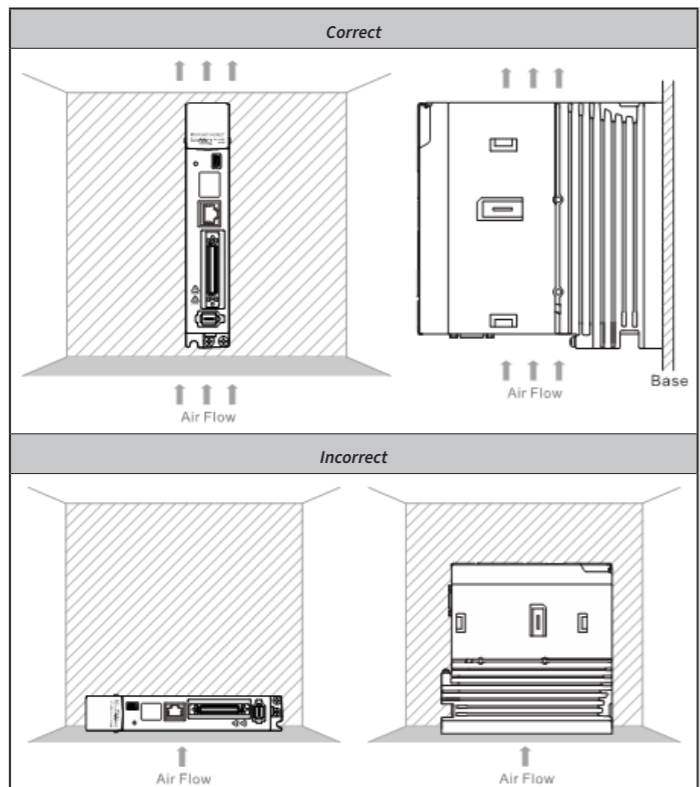

Installation: In order to have adequate air flow for ventilation, follow the suggested clearances as shown in the following diagram when installing one or more servo drives.

Servo Drive	Cooling Method	Minimum distance (d) corresponding to the operating temperature (Ta)*
SV2A-4040 SV2A-4075 SV2A-4150 SV2A-4200 SV2A-4300 SV2A-4550 SV2A-4750 SV2A-4F00	Natural cooling plus forced cooling	

* The servo drive requires a minimum clearance of 1mm

(6) BASIC INSPECTION

Item	Description
General Inspection	<ul style="list-style-type: none"> Periodically check to confirm the screws are securely tightened. This includes the screws in the servo drive, the connection screws between the motor shaft and machine, and the connection screws between the terminal block and machine. Prevent oil, water, metallic particles, and other foreign matter from entering the control box or ventilation equipment. Protect the servo drive from any drill cuttings. If the control box is installed in a location where dust or harmful gas are present, ensure the dust or harmful gas cannot enter the control box. Make sure to wire encoders and other devices in the proper sequence to avoid sudden unintended acceleration or damage to the motor.
Inspection before operation (power is not applied)	<ul style="list-style-type: none"> To avoid electric shock, connect the ground terminal of the servo drive to the ground terminal of the control box. If wiring must be added or modified, wait at least 10 minutes after disconnecting the servo drive from the power supply or discharge the electricity with a discharge device. Isolate the wires at the wiring terminal. Make sure the wiring is correct to avoid damage or any abnormal operation. Check for and remove any electrically conductive objects, including metal sheet and screws, or flammable objects inside or near the servo drive. Make sure the STO circuit is OFF. To ensure the electromagnetic brake works, make sure the stop and circuit breaker functions are working properly. Reduce the electromagnetic interference if there is electromagnetic interference with the peripheral devices. Make sure the external voltage level of the servo drive is correct.
Inspection before operation (power is applied)	<ul style="list-style-type: none"> The encoder cable should be protected from excessive stress – make sure the cable is not worn or stretched. Contact AutomationDirect if the servo motor vibrates or makes unusual noise during operation. Make sure the parameter settings are correct. Different machines have different characteristics. Adjust the parameters according to the characteristics of each machine. Reset the parameters when the servo drive is in the Servo Off status to avoid possible malfunction. If there is no contact noise or other abnormal noise when the relay is operating, contact AutomationDirect Contact AutomationDirect if the power indicator or LED display does not function properly.

(7) WIRING

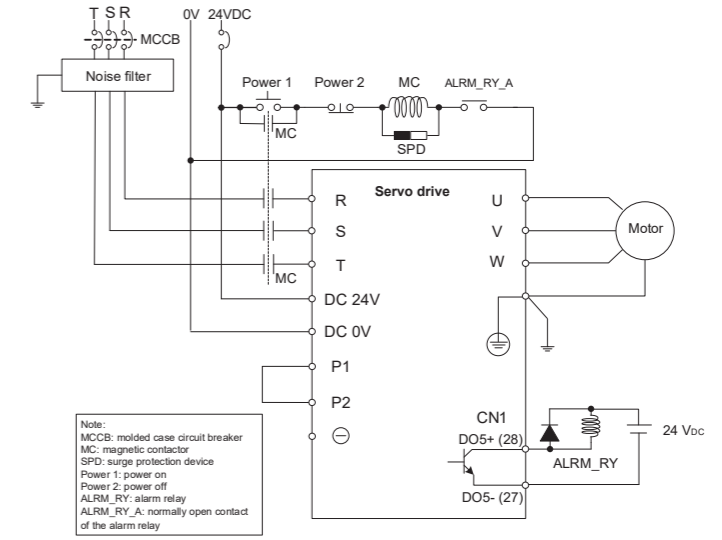

Note: The CN1 DO5 Digital Output shown in the diagram is the default Alarm Output for SureServo2 and is defaulted to normally closed.

(8) WIRING DIAGRAM FOR THE SERVO SYSTEM

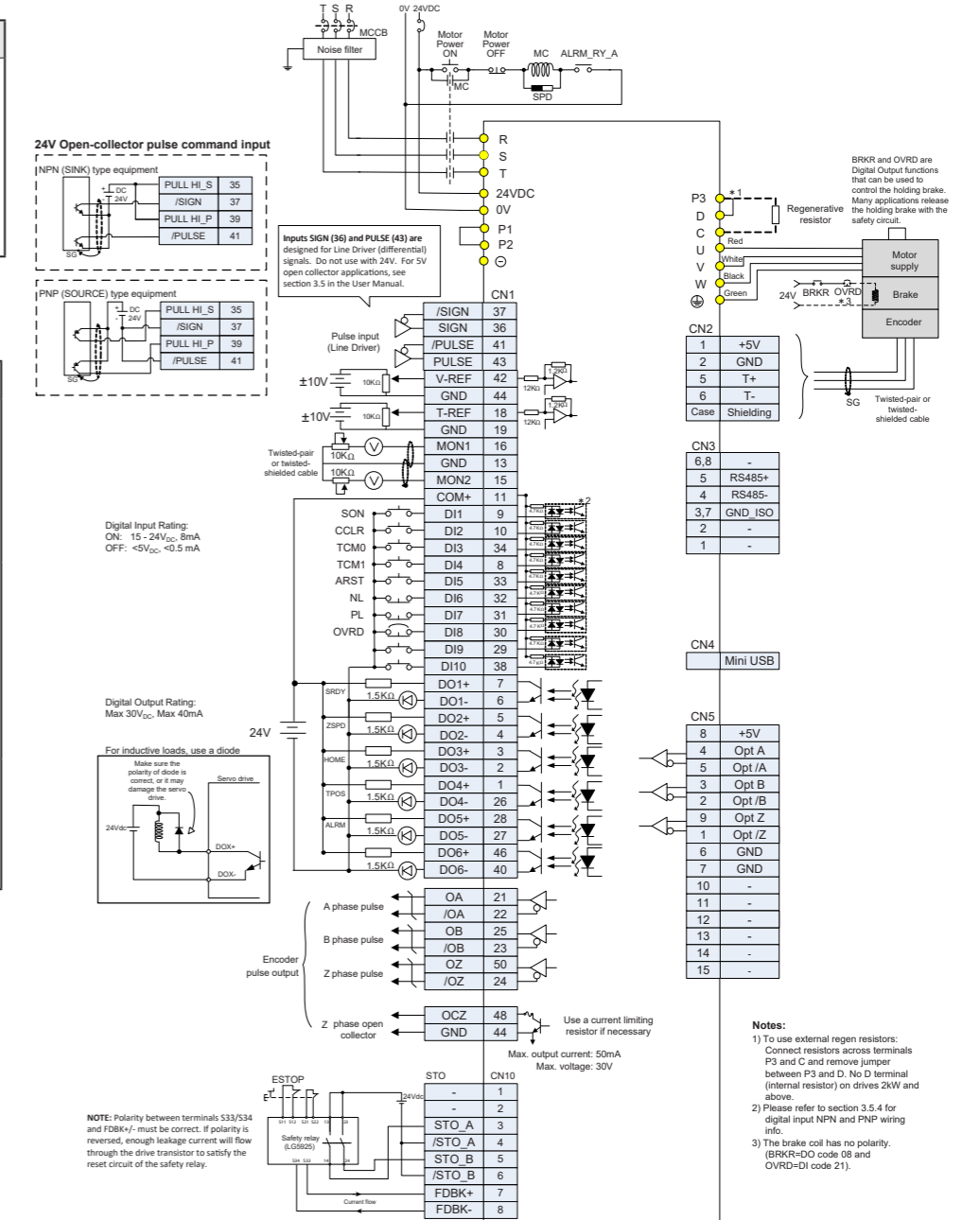

NOTE: Polarity between terminals S33/S34 and FDBK+/- must be correct. If polarity is reversed, enough leakage current will flow through the drive transistor to satisfy the reset circuit of the safety relay.

- Notes:
- To use external regen resistors: Connect resistors across terminals P3 and C and remove jumper between P3 and D. No D terminal (internal resistor) on drives 2kW and above.
 - Please refer to section 3.5.4 for digital input NPN and PNP wiring info.
 - The brake coil has no polarity. (BRKR=DO code 08 and OVRD=D1 code 21).

(9) DIMENSIONS AND WEIGHT OF SERVO DRIVE

SV2A-4040, 4075, 4150
Units = mm [in]

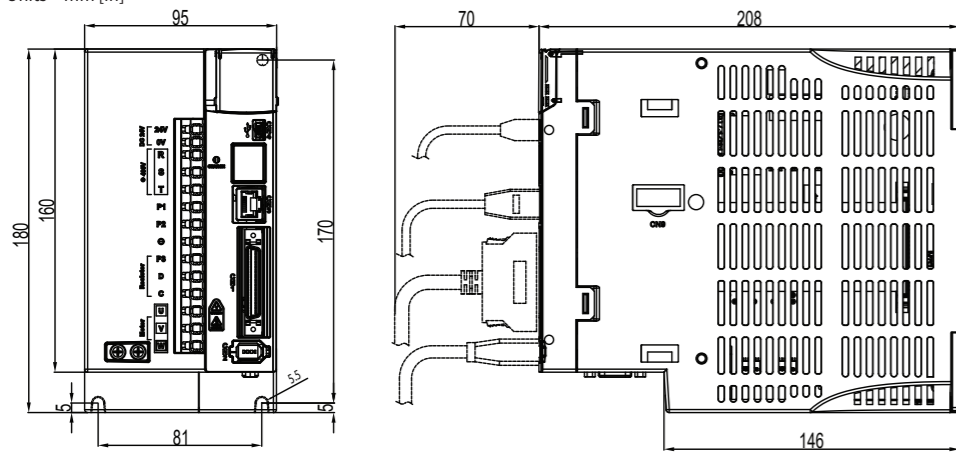

SV2A-4200, 4300
Units = mm [in]

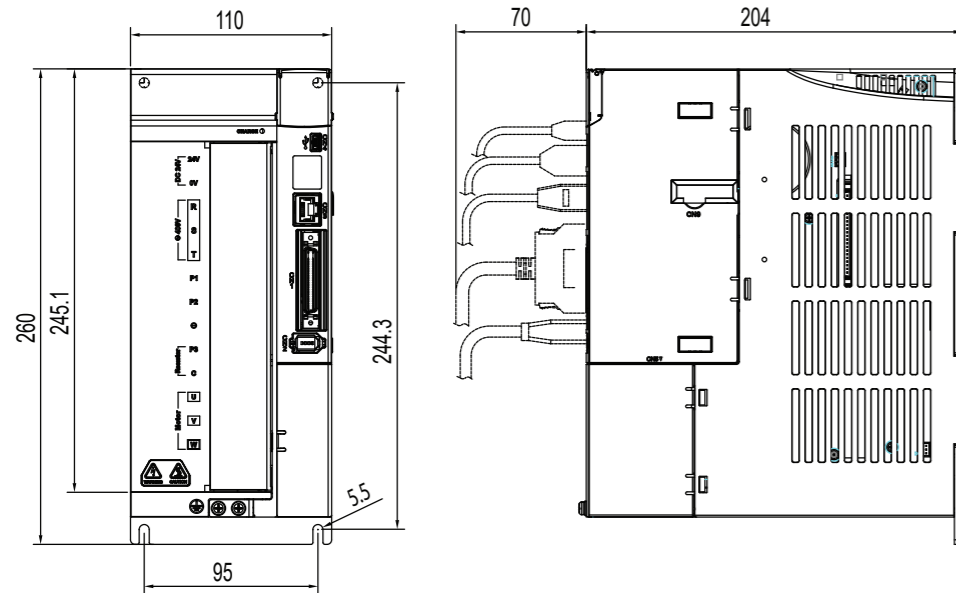

SV2A-4550
Units = mm [in]

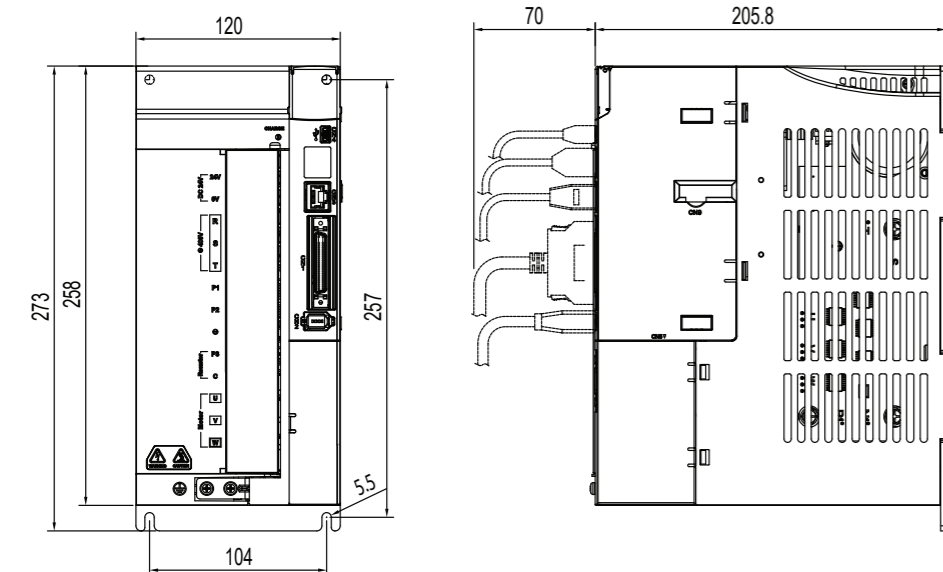

SV2A-4750
Units = mm [in]

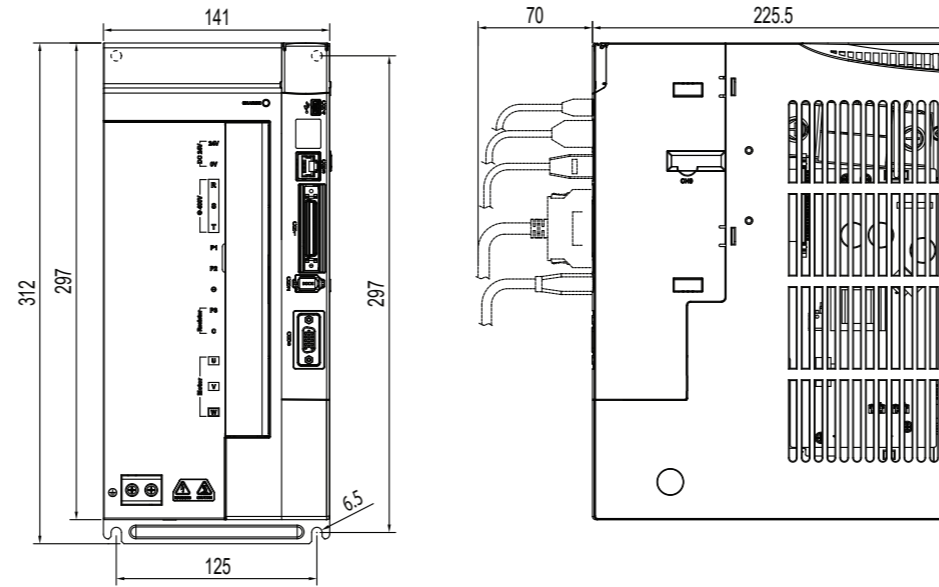

SV2A-4F00
Units = mm [in]

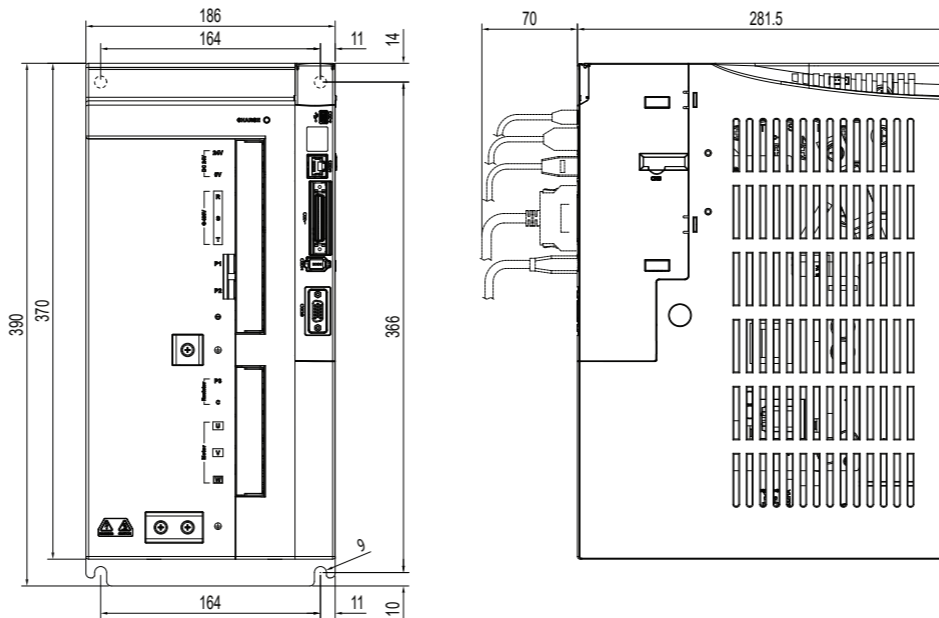

(10) CIRCUIT PROTECTION (MAXIMUM ALLOWABLE VALUES)

Servo Drive	Main Voltage Level	Drive Rated Input	Circuit Breaker	Fuse	Fuse Class
SV2A-4040	380-480 VAC 3-phase	1.49 A	10A	10A	Class CC
SV2A-4075		2.31 A	10A	15A	
SV2A-4150		4.98 A	15A	20A	
SV2A-4200		6.29 A	20A	25A	
SV2A-4300		9.92 A	20A	30A	Class J or High Speed J
SV2A-4550		16.83 A	35A	35A	
SV2A-4750		23.06 A	45A	45A	
SV2A-4F00		36.65 A	60A	90A	

These circuit protection values are the maximum values allowed by UL. These ratings take into account overload situations (300% rated input in many cases). See section 3) Wire Selection for recommended wire and circuit protection values. Always follow all local and national electrical codes when selecting circuit protection.

Use a DC-rated circuit breaker or fuse for the 24VDC supply power. Due to inrush, each drive control circuit should have separate circuit protection (don't supply two drives with one breaker).

24VDC Control Power	400W-1.5 kW	2kW-7.5 kW	15kW
Circuit Breaker or Fuse Rating	3A	5A	7A

(11) QUICK START GUIDE

This section will show how to safely and quickly start up a SureServo2 (SS2) drive. Wiring and starting up the drive should only be performed by a qualified professional. High voltage levels are in use.

Commissioning is quicker and easier using the drive configuration software SV2-PRO, but the entire start-up procedure can be accomplished with the keypad (detailed here). For further information and more complete startup instructions, please download the SureServo2 User Manual (SS2 UM) from www.automationdirect.com. Be sure to visit www.automationdirect.com/videos for helpful videos covering SureServo2 commissioning, programming, and operation.

PRELIMINARY WIRING

To safely and quickly start up a SureServo2 (SS2) drive, several different types of wiring need to be verified first. Until this wiring and functionality is verified, it is highly recommended to NOT connect main incoming power (R,S,T) or connect the load to the motor shaft.

- 1) Connect the ground wires to the screws at the bottom of the drive. Connect the incoming ground to one screw and connect the motor ground to the other screw. (The motor ground wire is in the motor cable SV2C-Pxxx-xxxx.)
- 2) Connect the wiring for 24VDC and 0V. This is control power and should be continuously available (not disconnected with E-stop, etc.).
- 3) Connect an appropriate safety circuit to CN10. See the wiring diagram elsewhere in this document or the SureServo2 User Manual. Although the CN10 connector comes pre-wired with an STO bypass, it is strongly recommended to wire a safety relay to connect STO_A to /STO_A and to connect STO_B to /STO_B.
- 4) Connect the motor encoder cable (SV2C-Exxx-xxxx) to the motor and to CN2 of the drive.
- 5) Connect the appropriate 24VDC input devices to DI1-DI10. Pay close attention to these Digital Input (DI) definitions. Their default (out-of-the-box) configurations are listed below.
 - DI1 = Servo On input (wired normally open)
 - DI5 = Alarm Reset (wired normally open)
 - DI6 and DI7 = Overtravel inputs. Inputs are wired normally closed (in a fail-safe manner). If the application is rotary and has no overtravel inputs, these inputs can be temporarily wired to DC common (0 volts) or disabled thru programming (procedure shown below).
 - DI8 = Override (temporary Motor Stop input wired normally closed). NOTE: The STO input (CN10) is separate from the Override (temporary Motor Stop input wired normally closed) input DI8.

APPLY CONTROL POWER AND RESET TO FACTORY DEFAULTS

Once the preliminary wiring previously described is complete, control power can be applied to the servo. Apply 24VDC power to the 24VDC and 0V terminals; and apply 24VDC to the I/O (CN1 connector).

To ensure that the drive has all default settings, reset the drive. To do this, enter a value of 10 into P2.008. On the drive's keypad:

[These are the general instructions on how to set any Parameter address value]

- 1) Press M to enter Parameter Mode. (Press M until you see a parameter address that begins with P, like P0.000.)
- 2) Press ← to advance to the P2 group
- 3) Press ▲ or ▼ to advance to P2.008
- 4) Press S to enter P2.008 and see the current value
- 5) Press ▲ or ▼ to change the value to 10
- 6) Press S to set the value.
- 7) The drive will display SAVED, BUSY, then DONE.

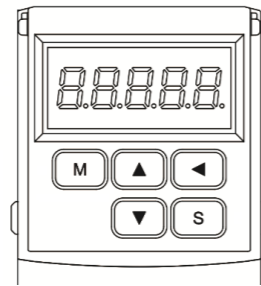

Cycle power to the drive. The drive will now contain all factory default settings.

CLEAR THE ALARMS

The drive will power up with alarms. The most common alarms are listed below with the most common solutions. For more detailed information and all possible alarm codes, search for the alarm code (ALxx) in the SS2 UM.

Display	Alarm Name	Solution (see the UM for more details)
AL500	STO Enabled	Enable the safety circuit to connect the STO signals (CN10). When the safety circuit is enabled, this alarm can be cleared. Reset with DI5 Alarm Reset. For temporary testing without a load attached to the motor, the supplied jumpers on the CN10 connector can bypass the STO feature.
AL501 AL502 AL503	STO Errors	These alarms occur when the STO inputs are not simultaneously active/inactive. Ensure proper wiring and activation of the safety circuit. Reset by cycling power to the drive.
AL003	Undervoltage	This alarm occurs when the main motor power (R,S,T) is not present and the Servo On input (DI1) is ON. At this point of commissioning, ensure that R,S, and T do NOT have power and that DI1 is OFF. Reset this alarm with DI5 Alarm Reset.
AL011	Encoder error	Ensure the encoder is connected. Verify the wiring on CN2. Ensure the motor ground and drive ground are properly connected. Reset by cycling drive power.
AL013	Motor Override	Ensure that DI8 Motor Override is ON (DI8 is configured Normally Closed as default). ON = current flowing = no fault.
AL014 AL015	Overtravel Limit	Ensure that DI6 and DI7 are ON or redefine the inputs (see below). These inputs are defined Normally Closed as default. ON = current flowing = no fault.

SYSTEM COMMISSIONING

The following procedures will quickly get your SureServo2 system up and running by using the keypad on the front of the drive.

To instead use the SureServo2 Pro software to commission your system (much easier), please view the SureServo2 QuickStart videos. Go to www.AutomationDirect.com and view any SureServo2 drive Item Page (SV2A-4040, etc.). Scroll down to the Related Videos section at the bottom and view these two SureServo2 QuickStart videos:

- [QuickStart Part 1: Hardware](http://www.automationdirect.com/VID-SV-0082) (www.automationdirect.com/VID-SV-0082)
- [QuickStart Part 2: Basics and Jog](http://www.automationdirect.com/VID-SV-0056) (www.automationdirect.com/VID-SV-0056)

CHANGE THE DIGITAL INPUT DEFINITION

If the application does not call for Overtravel limits, the definitions of DI6 and DI7 can be changed so that alarms AL014 and AL015 are not active. To disable DI6 and DI7 by changing parameters through the keypad, perform the following keystrokes:

- 1) Press M to enter Parameter Mode. (Press M until you see a parameter address that begins with P, like P0.000.)
 - 2) Press ← to advance to the P2 group
 - 3) Press ▲ or ▼ to advance to P2.015 (DI6 functional planning)
 - 4) Press S to enter P2.015 and see the current value (default = 022 = Negative overtravel)
 - 5) Press ▲ or ▼ to change the value to 000 to disable the input
- Note: ← moves the cursor left one digit (required for some parameter entry).
- 6) Press S to set the value.
 - 7) Repeat the procedure to disable P2.016 (DI7) if desired.

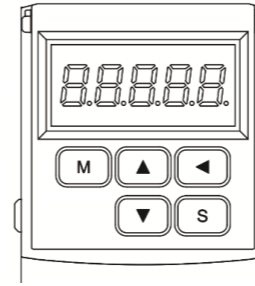

Digital Input	Input Def. Parameter	Default Definition (hex values)	Notes (corresponding Alarm)	Necessary for Startup?
DI1	P2.010	0101 = Servo On	Enables the servo	Yes
DI2	P2.011	0104 = Clear Pulses	Clears accumulated input pulses	No
DI3	P2.012	0116 = Torque Cmd 0	Torque Select Bit 0 (when in Torque mode)	No
DI4	P2.013	0117 = Torque Cmd 1	Torque Select Bit 1 (when in Torque mode)	No
DI5	P2.014	0102 = Alarm Reset	Clears alarms	Yes
DI6	P2.015	0022 = CW Overtravel	Disables motion in CW direction (AL014)	Yes (or disable to clear alarms)
DI7	P2.016	0023 = CCW Overtravel	Disables motion in CCW direction (AL015)	Yes (or disable to clear alarms)
DI8	P2.017	0021 = Motor Override	Stops motor immediately. (AL013). Motor can restart when this DI is switched OFF	Yes
DI9	P2.036	0100 = Disabled	Defined as Disabled and Normally Open	No
DI10	P2.037	0100 = Disabled	Defined as Disabled and Normally Open	No

Note: Setting the least two digits of P2.010 – P2.037 to 00 disables the input. The third digit signifies Normally Open or Normally Closed. Input Definitions with 1xx are Normally Open. DI is ON when current is flowing thru the terminals. Definitions with 0xx are Normally Closed. DI is ON when current is NOT flowing thru the terminals. (We recommended setting disabled inputs to 100, so the logic states are OFF when not energized.)

VERIFY ENCODER FEEDBACK

On the keypad, press M to cycle the display off of Parameter addresses (P2.015, etc.) or any active alarms (AL500, etc.). The display will now show Drive Status. Press ▲ or ▼ until Fb.PUU is displayed. After 1 second, the drive will display the Feedback Pulses in User Units. Rotate the shaft manually clockwise. The display should increment from 0-99,999 for one motor rotation. Decimal points beside the 4th and 5th digits indicate a negative position. This is a quick indication of which side of absolute zero the motor feedback is on. If an encoder alarm or unexpected feedback is seen, check all encoder cabling from the drive's CN2 to the motor. Check for loose connections or crossed wiring. See the UM for more help.

VERIFY DIGITAL INPUTS

Set P0.002 to 39 to display the DI status (in hex format) on the drive's LED display. As long as energizing the input does not trigger an alarm, the LED display will report the Digital Input status in hex. If an input does trigger an alarm (example: if DI8 is set for Motor Override and the input is ON), AL.xxx overrides the DI display (AL013 = Motor Override). Press M to cycle the LED back to the DI status display.

If the Digital Input is defined as Normally Closed (the function code is 0xx), the input will be considered active (ON) if there is no current flowing thru the terminal. Note: inputs defined as 000 are disabled, but are considered ON (Normally Closed) if there is no current flowing thru the terminals. To redefine the inputs, see **Change the Digital Input Definition** section above.

If this is the only input that is ON	This is the LED display (data in hex) when P0.002=39	Data in Binary (DI1=bit 0, DI2=bit 1, etc.)
DI1	L0001	0000 0000 0000 0001
DI2	L0002	0000 0000 0000 0010
DI3	L0004	0000 0000 0000 0100
DI4	L0008	0000 0000 0000 1000
DI5	L0010	0000 0000 0001 0000
DI6	L0020	0000 0000 0010 0000
DI7	L0040	0000 0000 0100 0000
DI8	L0080	0000 0000 1000 0000
DI9	L0100	0000 0001 0000 0000
DI10	L0200	0000 0010 0000 0000

If multiple inputs are ON at the same time, add the above results.

If These Inputs are ON	This is the LED display (data in hex) when P0.002=39	Data in Binary (DI1=bit 0, DI2=bit 1, etc.)
DI1 and DI2	L0003	0000 0000 0000 0011
DI4 and DI5	L0018	0000 0000 0001 1000

VERIFY DIGITAL OUTPUTS (DOs)

The Digital Outputs can be forced ON without requiring the corresponding DO function to be active. To put the outputs into Diagnostic Mode, set P2.008 to the value 406. Select the Digital Outputs to force ON and OFF by setting the hex value in P4.006. Each DO is forced ON by the corresponding bit set in P4.006. (DO1 = bit 0, DO2 = bit 1, etc.). Press ← to move the cursor left one digit. Press S to set (apply) the force to the outputs.

To Force this Output ON	Set this value in P4.006	Data in Binary
DO1	0001	0000 0001
DO2	0002	0000 0010
DO3	0004	0000 0100
DO4	0008	0000 1000
DO5	0010	0001 0000
DO6	0020	0010 0000

Multiple outputs can be forced ON at the same time. Examples:

To Force this Output ON	Set this value in P4.006	Data in Binary
DO1 + DO2	0003	0000 0011
All (DO1-DO6)	003F	0011 1111

Once DO testing/verification is complete, exit DO Diagnostic Mode by cycling control power to the drive.

CONNECT MOTOR POWER AND SPIN THE MOTOR (w/o LOAD)

Note: We highly recommended not connecting the motor to the load before verifying proper motor operation. When first spinning the motor, the shaft should not be connected to anything.

- 1) Connect a motor power cable to the motor and drive (Ground=green, U=red, V=white, W=black).
- 2) Re-verify incoming control power (L1C, L2C), DI/DO wiring (including 24VDC power), and STO wiring (CN10).
- 3) Ensure that the Servo ON input (DI1) is not ON.
- 4) If using a brake motor, connect 24VDC to the brake wires to release the brake. Polarity is not important.
- 5) Connect incoming main power to the drive (Ground, R,S,T).
- 6) If any alarms are present, correct the alarms (refer to the explanation above for common alarms, refer to the UM for more information).

The drive can be jogged from the keypad to verify operation.

- 7) Enable the Servo ON input with DI1. The motor should lock into position.
- 8) Refer back to Step #4. It is embarrassing if you forget to release the brake.
- 9) Set the desired Jog Speed in P4.005 (or press S to accept the default 20rpm in P4.005):
The display will now display -JOG-

Note: If the display shows SV-On, enable Servo ON with DI1 and repeat Step 9.

- 10) Use ▲ and ▼ to jog the motor forward and reverse. Press M to change speed.
Cycle the drive's control power to exit Jog Mode.

Note: the display will not annunciate alarms while in Jog Mode.

Once the motor successfully jogs, the motor, feedback, and drive have been shown to be properly installed. The system can now be programmed and commissioned along with the control system. There are tables at the beginning of Parameters Chapter 8 in the User Manual that detail the most common parameters used for the different drive control modes:

- PT Mode:** Position control – Terminals (high speed pulse input commands)
- PR mode:** Position control – Registers (point-to-point moves using internal registers for setpoints)
This mode includes point to point moves, registration, and camming
- S Modes:** Speed/Velocity control
S = analog input speed command
Sz = internal speed registers that include a zero-speed setting
- T modes:** Torque control
T = analog input torque command
Tz = internal torque registers that include a zero-torque setting

FIRMWARE UPGRADE

Occasionally, there will be new servo drive firmware to add new features or correct problems. Go to <http://www.automationdirect.com> and search for your servo drive part number. On that part number's item page you will find a link for the latest SureServo2 firmware. Compare the website's current firmware version to P0.000 (firmware version) and P5.000 (firmware sub-version) in the servo drive. If the versions match, your drive has the latest firmware. If the online version is higher than P0.000, download the firmware file from automationdirect.com. Next, open SureServo2 Pro software and connect to the drive. Then select "Burn" from the pull-down menus to update your drive's firmware. Please see the SureServo2 Pro help file for detailed instructions and more information.