

**Stride™**

**SIOL-EI8B**

**IO-Link Master Basic**

**EtherNet/IP DIO8 IOL8 M12L 5P**

Powered by  **MURR**  
**ELEKTRONIK**

User Manual

#SIOL-EI8B-USER-M

 **AUTOMATIONDIRECT.com**

## ⚡ WARNING ⚡

Thank you for purchasing automation equipment from Automationdirect.com®, doing business as AutomationDirect. We want your new automation equipment to operate safely. Anyone who installs or uses this equipment should read this publication (and any other relevant publications) before installing or operating the equipment.

To minimize the risk of potential safety problems, you should follow all applicable local and national codes that regulate the installation and operation of your equipment. These codes vary from area to area and usually change with time. It is your responsibility to determine which codes should be followed, and to verify that the equipment, installation, and operation is in compliance with the latest revision of these codes.

At a minimum, you should follow all applicable sections of the National Fire Code, National Electrical Code, and the codes of the National Electrical Manufacturer's Association (NEMA). There may be local regulatory or government offices that can also help determine which codes and standards are necessary for safe installation and operation.

Equipment damage or serious injury to personnel can result from the failure to follow all applicable codes and standards. We do not guarantee the products described in this publication are suitable for your particular application, nor do we assume any responsibility for your product design, installation, or operation.

Our products are not fault-tolerant and are not designed, manufactured or intended for use or resale as on-line control equipment in hazardous environments requiring fail-safe performance, such as in the operation of nuclear facilities, aircraft navigation or communication systems, air traffic control, direct life support machines, or weapons systems, in which the failure of the product could lead directly to death, personal injury, or severe physical or environmental damage ("High Risk Activities"). AutomationDirect specifically disclaims any expressed or implied warranty of fitness for High Risk Activities.

For additional warranty and safety information, see the Terms and Conditions on our website. If you have any questions concerning the installation or operation of this equipment, or if you need additional information, please call us at **770-844-4200**.

This publication is based on information that was available at the time it was published. At AutomationDirect we constantly strive to improve our products and services, so we reserve the right to make changes to the products and/or publications at any time without notice and without any obligation. This publication may also discuss features that may not be available in certain revisions of the product.

## TRADEMARKS

This publication may contain references to products produced and/or offered by other companies. The product and company names may be trademarked and are the sole property of their respective owners. AutomationDirect disclaims any proprietary interest in the marks and names of others.

***COPYRIGHT 2022–2024 AUTOMATIONDIRECT.COM® INCORPORATED  
ALL RIGHTS RESERVED***

No part of this manual shall be copied, reproduced, or transmitted in any way without the prior, written consent of Automationdirect.com® Incorporated. AutomationDirect retains the exclusive rights to all information included in this document.

## ⚡ ADVERTENCIA ⚡

Gracias por comprar equipo de automatización de Automationdirect.com®. Deseamos que su nuevo equipo de automatización opere de manera segura. Cualquier persona que instale o use este equipo debe leer esta publicación (y cualquier otra publicación pertinente) antes de instalar u operar el equipo.

Para reducir al mínimo el riesgo debido a problemas de seguridad, debe seguir todos los códigos de seguridad locales o nacionales aplicables que regulan la instalación y operación de su equipo. Estos códigos varían de área en área y usualmente cambian con el tiempo. Es su responsabilidad determinar cuales códigos deben ser seguidos y verificar que el equipo, instalación y operación estén en cumplimiento con la revisión más reciente de estos códigos.

Como mínimo, debe seguir las secciones aplicables del Código Nacional de Incendio, Código Nacional Eléctrico, y los códigos de (NEMA) la Asociación Nacional de Fabricantes Eléctricos de USA. Puede haber oficinas de normas locales o del gobierno que pueden ayudar a determinar cuales códigos y normas son necesarios para una instalación y operación segura.

Si no se siguen todos los códigos y normas aplicables, puede resultar en daños al equipo o lesiones serias a personas. No garantizamos los productos descritos en esta publicación para ser adecuados para su aplicación en particular, ni asumimos ninguna responsabilidad por el diseño de su producto, la instalación u operación.

Nuestros productos no son tolerantes a fallas y no han sido diseñados, fabricados o intencionados para uso o reventa como equipo de control en línea en ambientes peligrosos que requieren una ejecución sin fallas, tales como operación en instalaciones nucleares, sistemas de navegación aérea, o de comunicación, control de tráfico aéreo, máquinas de soporte de vida o sistemas de armamentos en las cuales la falla del producto puede resultar directamente en muerte, heridas personales, o daños físicos o ambientales severos (“Actividades de Alto Riesgo”). Automationdirect.com específicamente rechaza cualquier garantía ya sea expresada o implicada para actividades de alto riesgo.

Para información adicional acerca de garantía e información de seguridad, vea la sección de Términos y Condiciones. Si tiene alguna pregunta sobre instalación u operación de este equipo, o si necesita información adicional, por favor llámenos al número **770-844-4200** en Estados Unidos.

Esta publicación está basada en la información disponible al momento de la publicación. En Automationdirect.com nos esforzamos constantemente para mejorar nuestros productos y servicios, así que nos reservamos el derecho de hacer cambios al producto y/o a las publicaciones en cualquier momento sin notificación y sin ninguna obligación. Esta publicación también puede discutir características que no estén disponibles en ciertas revisiones del producto.

## MARCAS REGISTRADAS

Esta publicación puede contener referencias a productos producidos y/u ofrecidos por otras compañías. Los nombres de las compañías y productos pueden tener marcas registradas y son propiedad única de sus respectivos dueños. Automationdirect.com, renuncia cualquier interés propietario en las marcas y nombres de otros.

**PROPIEDAD LITERARIA 2022–2024, AUTOMATIONDIRECT.COM® INCORPORATED**

**TODOS LOS DERECHOS RESERVADOS**

No se permite copiar, reproducir, o transmitir de ninguna forma ninguna parte de este manual sin previo consentimiento por escrito de Automationdirect.com® Incorporated. Automationdirect.com retiene los derechos exclusivos a toda la información incluida en este documento. Los usuarios de este equipo pueden copiar este documento solamente para instalar, configurar y mantener el equipo correspondiente. También las instituciones de enseñanza pueden usar este manual para propósitos educativos.

## ⚡ AVERTISSEMENT ⚡

Nous vous remercions d'avoir acheté l'équipement d'automatisation de AutomationDirect.com®, en faisant des affaires comme AutomationDirect. Nous tenons à ce que votre nouvel équipement d'automatisation fonctionne en toute sécurité. Toute personne qui installe ou utilise cet équipement doit lire la présente publication (et toutes les autres publications pertinentes) avant de l'installer ou de l'utiliser.

Afin de réduire au minimum le risque d'éventuels problèmes de sécurité, vous devez respecter tous les codes locaux et nationaux applicables régissant l'installation et le fonctionnement de votre équipement. Ces codes diffèrent d'une région à l'autre et, habituellement, évoluent au fil du temps. Il vous incombe de déterminer les codes à respecter et de vous assurer que l'équipement, l'installation et le fonctionnement sont conformes aux exigences de la version la plus récente de ces codes.

Vous devez, à tout le moins, respecter toutes les sections applicables du Code national de prévention des incendies, du Code national de l'électricité et des codes de la National Electrical Manufacturer's Association (NEMA). Des organismes de réglementation ou des services gouvernementaux locaux peuvent également vous aider à déterminer les codes ainsi que les normes à respecter pour assurer une installation et un fonctionnement sûrs.

L'omission de respecter la totalité des codes et des normes applicables peut entraîner des dommages à l'équipement ou causer de graves blessures au personnel. Nous ne garantissons pas que les produits décrits dans cette publication conviennent à votre application particulière et nous n'assumons aucune responsabilité à l'égard de la conception, de l'installation ou du fonctionnement de votre produit.

Nos produits ne sont pas insensibles aux défaillances et ne sont ni conçus ni fabriqués pour l'utilisation ou la revente en tant qu'équipement de commande en ligne dans des environnements dangereux nécessitant une sécurité absolue, par exemple, l'exploitation d'installations nucléaires, les systèmes de navigation aérienne ou de communication, le contrôle de la circulation aérienne, les équipements de survie ou les systèmes d'armes, pour lesquels la défaillance du produit peut provoquer la mort, des blessures corporelles ou de graves dommages matériels ou environnementaux («activités à risque élevé»). La société AutomationDirect nie toute garantie expresse ou implicite d'aptitude à l'emploi en ce qui a trait aux activités à risque élevé.

Pour des renseignements additionnels touchant la garantie et la sécurité, veuillez consulter la section Modalités et conditions de notre documentation. Si vous avez des questions au sujet de l'installation ou du fonctionnement de cet équipement, ou encore si vous avez besoin de renseignements supplémentaires, n'hésitez pas à nous téléphoner au **770-844-4200**.

Cette publication s'appuie sur l'information qui était disponible au moment de la publication. À la société AutomationDirect, nous nous efforçons constamment d'améliorer nos produits et services. C'est pourquoi nous nous réservons le droit d'apporter des modifications aux produits ou aux publications en tout temps, sans préavis ni quelque obligation que ce soit. La présente publication peut aussi porter sur des caractéristiques susceptibles de ne pas être offertes dans certaines versions révisées du produit.

## MARQUES DE COMMERCE

La présente publication peut contenir des références à des produits fabriqués ou offerts par d'autres entreprises. Les désignations des produits et des entreprises peuvent être des marques de commerce et appartiennent exclusivement à leurs propriétaires respectifs. AutomationDirect nie tout intérêt dans les autres marques et désignations.

**COPYRIGHT 2022–2024 AUTOMATIONDIRECT.COM® INCORPORATED**  
**TOUS DROITS RÉSERVÉS**

Nulle partie de ce manuel ne doit être copiée, reproduite ou transmise de quelque façon que ce soit sans le consentement préalable écrit de la société AutomationDirect.com® Incorporated. AutomationDirect conserve les droits exclusifs à l'égard de tous les renseignements contenus dans le présent document.

# Stride IO-Link Master Basic User Manual

---



Please include the Manual Number and the Manual Issue, both shown below, when communicating with Technical Support regarding this publication.

**Manual Number:**     **SIOL-EI8B-USER-M**  
**Issue:**               **1st Edition, Rev. E**  
**Issue Date:**         **05/2024**

Publication History		
Issue	Date	Description of Changes
1st Edition	05/2022	Original release
1st Edition, Rev. A	09/2022	Added Required Fixed Data table.
1st Edition, Rev. B	11/2022	Clarified byte positions of configuration parameters.
1st Edition, Rev. C	08/2023	Updated screenshots for changes to EDS file.
1st Edition, Rev. D	04/2024	Clarified effect of rotary switch setting on IP subnet.
1st Edition, Rev. E	05/2024	Corrected formatting error in System Status Bit String table

# Table of Contents

<b>1.</b>	<b>Introduction</b>	<b>1</b>
1.1.	Applicable documents	1
1.2.	About this manual	2
1.2.1.	Symbols	2
1.2.2.	Trademarks	2
1.2.3.	Specifications	2
1.2.4.	Software tools	2
<b>2.</b>	<b>For your safety</b>	<b>3</b>
2.1.	General safety instructions	3
2.2.	Intended purpose	4
<b>3.</b>	<b>Description</b>	<b>5</b>
3.1.	Module	5
3.1.1.	Product Designation Code	5
3.1.2.	Module structure	6
3.1.3.	Connections	7
3.1.3.1.	Pin assignments	7
3.1.4.	Display elements	8
3.1.5.	Rotary switch settings	9
3.2.	IO-Link	10
3.2.1.	Data storage	11
3.3.	EtherNet/IP	12
3.3.1.	Communication	12
3.3.2.	RPI	13
3.3.3.	Device Level Ring (DLR)	13
<b>4.</b>	<b>Technical Data</b>	<b>14</b>
4.1.	Electrical Data	14
4.2.	Environmental characteristics	17
4.3.	Protection	17
4.4.	Mechanical data	18
4.5.	Conformity, Approvals	18
<b>5.</b>	<b>Mounting</b>	<b>19</b>
5.1.	Requirements	19
5.2.	Dimensions	19
5.3.	Mounting clearance	20
5.4.	Mounting the module	21
5.4.1.	Functional ground	22
5.4.2.	Rotary switch cover	23

<b>6.</b>	<b>Installation</b>	<b>24</b>
6.1.	Electrical Installation of the Module	24
6.1.1.	Connecting sensors and actuators	25
6.1.2.	Connecting Ethernet bus	26
6.1.3.	Connecting the power supply	27
6.2.	Ensuring Tightness (IP67)	28
<b>7.</b>	<b>Startup</b>	<b>29</b>
7.1.	Loading the EDS files	30
7.2.	Adding a module as an EtherNet/IP Device	32
7.3.	Productivity Suite Integration Library	37
7.4.	Commissioning without EDS	44
7.4.1.	Connections, parameters and properties	44
7.4.2.	Connection matrix	44
7.4.3.	Assemblies	44
7.4.4.	Configuration values	46
<b>8.</b>	<b>Configuration and parameterization</b>	<b>56</b>
8.1.	Module configuration	56
8.2.	RPI configuration	58
8.3.	IO-Link configuration	59
<b>9.</b>	<b>Operation</b>	<b>60</b>
9.1.	LED indication	60
9.1.1.	LED assignment to channel and pin	60
9.1.2.	LED flashing behavior	60
9.1.3.	LED indication for inputs and outputs	61
9.1.4.	LED display MS and NS	62
9.1.5.	LED indication for LNK/ACT	63
9.1.6.	LED indication for State	63
9.1.7.	LED indication for POWER US and UA	64
9.1.8.	Extended LED indication	65
9.2.	Diagnostics	66
9.2.1.	Diagnostics structure in the control system	66
9.2.2.	Diagnostics in the WebUI	66
9.2.3.	Diagnostic value	67
9.2.3.1.	Short-circuit diagnostic	67
9.2.3.2.	Undervoltage diagnostic	67
9.2.3.3.	Overvoltage diagnostic	67
9.2.3.4.	General diagnostic	67
9.2.3.5.	Buffer overflow diagnostic	67
9.2.3.6.	IO-Link master diagnostic	68
9.2.3.7.	IO-Link device diagnostic	69

9.3.	Acyclic IO-Link device access	71
9.3.1.	Reading an IO-Link device index	71
9.3.2.	Writing an IO-Link device index	72
9.3.3.	CIP status codes	73
<b>10.</b>	<b>Web Server (WebUI)</b>	<b>74</b>
10.1.	Starting the WebUI	75
10.2.	Menu bar	76
10.2.1.	STATUS menu	76
10.2.2.	PARAMETERS menu	78
10.2.3.	DIAGNOSTICS menu	78
10.2.4.	MAINTENANCE menu	79
10.3.	IO-Link Master Port	80
10.3.1.	STATUS menu	80
10.3.2.	INFORMATION menu	82
10.3.3.	CONFIGURATION menu	83
10.3.4.	IO-LINK PARAMETER menu	83
10.3.5.	PROCESS DATA menu	84
10.4.	Settings / Maintenance	85
10.4.1.	DEVICE CONFIGURATION menu	85
10.4.2.	MAINTENANCE INFORMATION menu	86
10.4.3.	FIRMWARE menu	87
10.4.4.	FACTORY RESET menu	87
10.5.	User Administration	88
10.6.	Digital IO Channels / IO Overview	88
10.6.1.	Input data	88
10.6.2.	Output data	89
<b>11.</b>	<b>Maintenance and cleaning</b>	<b>91</b>
<b>Appendix A:</b>	<b>Supported EtherNet/IP objects</b>	<b>92</b>
A.1.	Standard object class	92
A.1.1.	Identity Object (Class Code: 0x01)	92
A.1.2.	Message Router Object (Class Code: 0x02)	93
A.1.3.	Assembly Object (Class Code: 0x04)	93
A.1.4.	Connection Manager Object (Class Code: 0x06)	94
A.1.5.	Device Level Ring (DLR) Object (Class Code: 0x47)	94
A.1.6.	Quality of Service Object (Class Code: 0x48)	95
A.1.7.	TCP/IP Interface Object (Class Code: 0xF5)	96
A.1.8.	Ethernet Link Object (Class Code: 0xF6)	97
A.2.	Vendor Specific Objects	99
A.2.1.	IO-Link Device Parameter Object (Class Code 0x83)	99

---

<b>Appendix B: Explanation of the process data</b>	<b>101</b>
B.1. System Status	101
B.2. IO-Link Port X Status	102
B.3. Diagnostic Buffer	102
B.4. Digital Output	102

---

<b>Appendix C: Configuring a Module Using Studio5000 Logix Designer</b>	<b>103</b>
C.1. Loading the EDS files	103
C.2. Adding a module to the network	105
C.3. Module configuration	110
C.4. RPI configuration	111

---

<b>Glossary</b>	<b>113</b>
-----------------	------------

---

<b>Legal notes</b>	<b>114</b>
--------------------	------------

---

# 1. Introduction

## Function of this document

This document instructs the technical personnel of the machine manufacturer or machine operator on the safe use of the devices described in the scope.

It does not include instructions on the safe use of the machine in which the devices are or will be integrated. Information on this is contained in the operating instructions for the machine.

- Read this chapter carefully before you start working with the documentation or the device.
- Read the documentation carefully before starting up the device.
- Store the manual in a place that is accessible to all users at all times for the entire service life of the device.

You will need general knowledge about automation engineering in order to understand this manual. In addition, planning and using automation systems requires technical knowledge which is not contained in this manual.

## 1.1. Applicable documents

### Other applicable documents

Document	Filename	Location
Product Data and Getting Started Instructions	SIOL-EI8B	Packaged with product and downloadable from <a href="https://go2adc.com/iolink">https://go2adc.com/iolink</a> .

### Environmentally friendly disposal



- Dispose of the product at the end of its service life according to the applicable statutory regulations.

## 1.2. About this manual

### 1.2.1. Symbols

This document includes information and notes that must be observed for your own safety and to avoid injuries and equipment damage. They are marked as follows:



#### **⚠ DANGER!**

##### **Immediate danger**

Failure to observe this warning involves an imminent risk of death or serious injuries.



#### **⚠ WARNING!**

##### **Possible danger**

Failure to observe this warning can lead to death or serious injuries.



#### **⚠ CAUTION!**

##### **Low-risk danger**

Failure to observe this warning can lead to mild or moderate injuries.

#### **NOTICE**

##### **Possible material damage**

Failure to observe the warning may cause damage to the device and/or the system.



#### **NOTE**

Other technical information and notes



#### **DOCUMENTATION RECOMMENDATION**

Notes with this symbol are references to additional information elsewhere in the documentation.

### Instructions for use

- An arrow marks instructions.
  - Read and follow the instructions.
1. If the instructions are numbered, it is absolutely necessary to follow them in the correct order.
  2. Read and follow the instructions in the order shown.

### 1.2.2. Trademarks

Trademarks of the following companies and institutions are used in this documentation:

<b>EtherNet/IP</b>	ODVA, Inc.
<b>IO-Link</b>	c/o PROFIBUS Nutzerorganization e.V. (PNO)
<b>STUDIO 5000 LOGIX DESIGNER</b>	Rockwell Automation Inc.

### 1.2.3. Specifications

Specification	Link
<b>EtherNet/IP</b> Specification	<a href="http://www.odva.org">http://www.odva.org</a>
<b>IO-Link</b> Version 1.1.2, dated 2013-07	<a href="http://www.io-link.com">http://www.io-link.com</a>



The features of IO-Link specification version 1.1.3 are also supported.

### 1.2.4. Software tools

Software used
Productivity Suite
Murrelektronik IO-Link Device Tool

## 2. For your safety

→ Read this chapter carefully before working with the fieldbus module.

### 2.1. General safety instructions



#### **⚠ DANGER!**

##### **High electrical voltage in the machine/system**

Death or severe injuries resulting from electric shock.

→ When working on the machine or modules, comply with all applicable requirements and recommendations.

#### **Protection of persons and material assets**

→ According to DIN VDE 0105-100 - Operation of electrical systems - Part 100: General definitions

#### **The five safety rules**

##### **Protect against high electrical voltage**

1. Disconnect
2. Secure against switching on again
3. Make sure that there is no voltage on all poles.
4. Ground and short-circuit
5. Cover or block off neighboring parts that are live or energized

#### **Qualified personnel**

Only qualified personnel instructed in safety are allowed to install the module and to put it into operation.

They are qualified if they meet the following requirements:

- They have undergone suitable electrical engineering training
- They were trained by the machine operator to operate the machine and instructed on the related safety regulations
- They have access to the Operating Instructions and this manual
- They are familiar with the safety standards which are common practice in automation engineering
- They are familiar with the basic and technical standards related to the specific application

#### **Use of the device**

→ Comply with all safety and accident prevention regulations when conducting project engineering, installation, commissioning, operation, and testing of the device.

→ Make sure this product is resistant to any chemical agents that may be used



#### **NOTE**

Maintenance of the hardware and software of the fieldbus module may only be performed by qualified personnel of Murrelektronik GmbH, with the exception of firmware updates.



#### **NOTE**

Use only a power supply unit that allows max. 60VDC or 25VAC under single-fault conditions. The power supply must comply with SELV or PELV.

**⚠ CAUTION!****Hot surface!**

Minor injuries and damage to devices caused by contact with the surface.

- Wear thermally suitable gloves.
- Use thermally suitable connecting cables only.

**Protective measures by the machine operator**

- Follow the instructions in this manual.
- Pay attention to the specifications and the operating instructions of all connected components.

## 2.2. Intended purpose

**Intended use**

The STRIDE IO-Link master is a decentralized device. It can be used in harsh industrial environments up to degree of protection IP67.

Operation of the device in accordance with its designated use and the degree of protection IP67 are only guaranteed if open male and female connectors are closed using screw plugs.

Designated use also includes EMC-compliant electrical installation. The device is designated for use in industrial environments. Radio interference may occur if used in domestic or mixed environments.

- If the fieldbus module is used in domestic or mixed environments, the applicable standards must be observed.

**Warnings**

- Do not alter the design, engineering, or electrical features of the module.
- Do not use the module outside the applications described in this manual, the Technical Data or in the operating instructions.
- Do not use the module as a safety-related device. It does not meet the relevant standards. Safety functions of the system are not ensured!
- Do not use the Off state of the module outputs for safety-related requirements of the system/machine!
- Do not use the module outdoors or for continuous operation in liquids.
- Do not clean the module with a high-pressure cleaner.
- Do not use the module as a climbing aid.

**Warranty and liability claims**

Warranty and liability claims become void if

- the product is not used according to its designated use,
- damage is caused because the manual and the operating instructions have not been observed,
- the personnel was / is not qualified.

## 3. Description

### 3.1. Module

The STRIDE IO-Link master is a fully encapsulated fieldbus module in a plastic case. It is particularly robust and designed for use in harsh environments.

Property	Description
Robust	Versatile applications exposed to harsh environments due to: <ul style="list-style-type: none"> <li>■ Robust plastic case,</li> <li>■ Resistant to condensation due to fully encapsulated case</li> </ul>
Vibration-proof	Reliable even when subjected to continuous vibration
Resistant	Long life due to acid and alkali resistant plastic
Reliable connections	Connections tested up to degree of protection IP67 (EN 60529)



#### 3.1.1. Product Designation Code

The designation is based on a scheme that indicates the product's function

Basic IO-Link Master E DIO8 IOL8 M12L 5P E DIO8 IOL8 M12L 5P	
E	Function E = EtherNet/IP
DIO IOL	I/O channels <ul style="list-style-type: none"> <li>■ D = Digital</li> <li>■ I = Input</li> <li>■ O = Output</li> <li>■ IOL = IO-Link</li> </ul>
<ul style="list-style-type: none"> <li>■ DIO8 8 digital inputs and outputs (DIO)</li> <li>■ IOL8 8 IO-Link</li> </ul>	Number of channels
M12L	L-coded power connection
5P	5-pin

## 3.1.2. Module structure

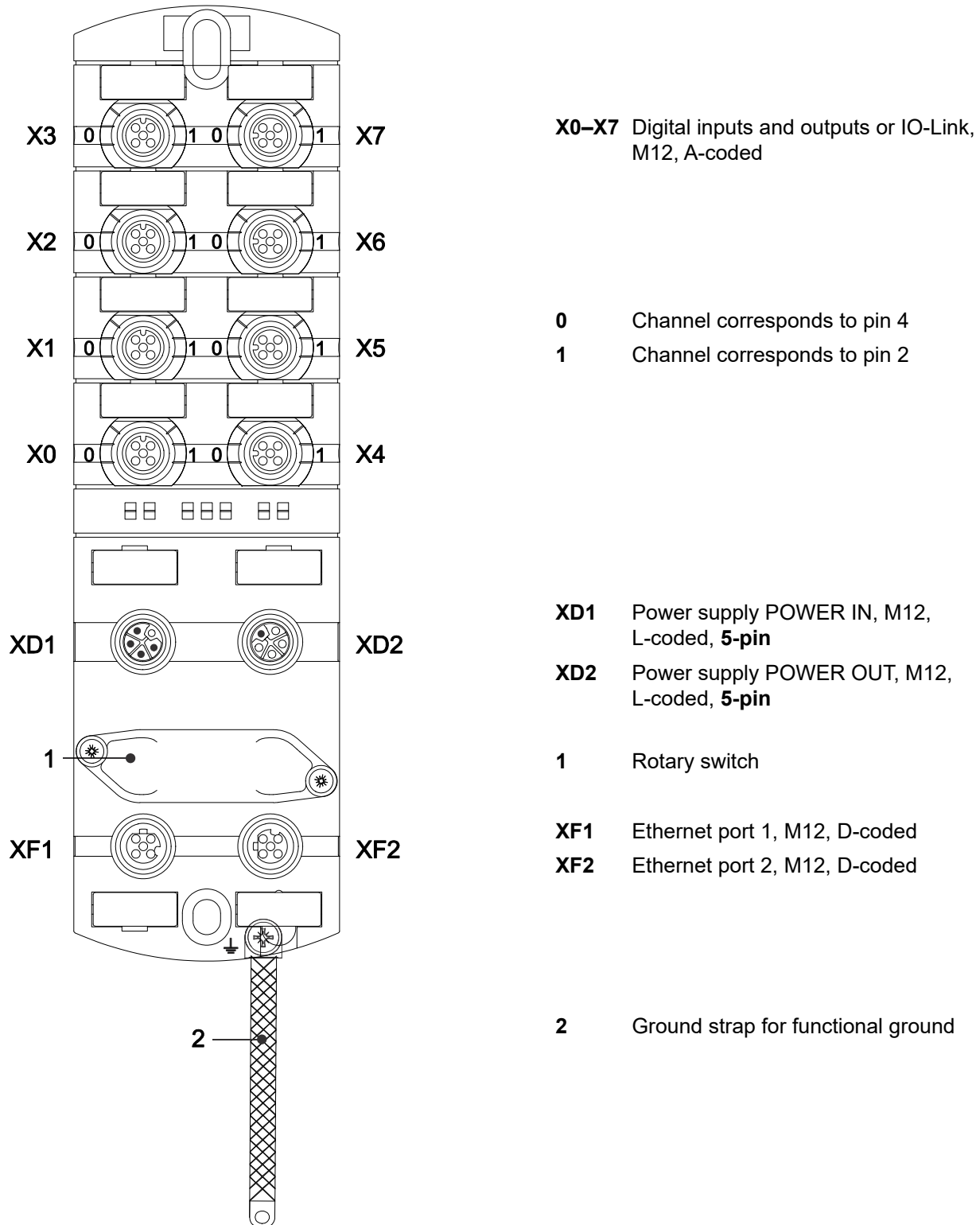
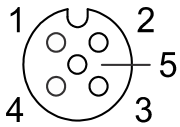
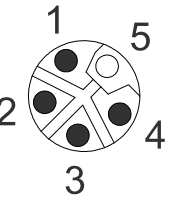
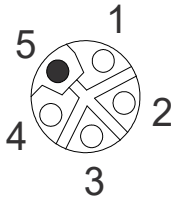

Fig. 3-1: Module structure

### 3.1.3. Connections

#### 3.1.3.1. Pin assignments

M12 Female Connector, A-coded		
X0-X7		
	Pin 1	24VDC $\overline{\text{---}}$
	Pin 2	DI/DO
	Pin 3	0V
	Pin 4	DI/DO/IO-Link
	Pin 5	0V

M12 Male/Female Connector, L-coded, POWER IN/OUT			
XD1		XD2	
	Pin 1	24VDC $\overline{\text{---}}$ US (operating voltage)	
	Pin 2	0V UA (actuator voltage)	
	Pin 3	0V US	
	Pin 4	24VDC $\overline{\text{---}}$ UA	
	Pin 5	$\perp$	

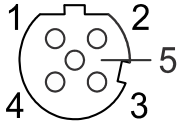
M12 Female Connector, D-coded, Port 1 / Port 2		
XF1/XF2		
	Pin 1	TD +
	Pin 2	RD +
	Pin 3	TD -
	Pin 4	RD -
	Pin 5	n.c.

## 3.1.4. Display elements

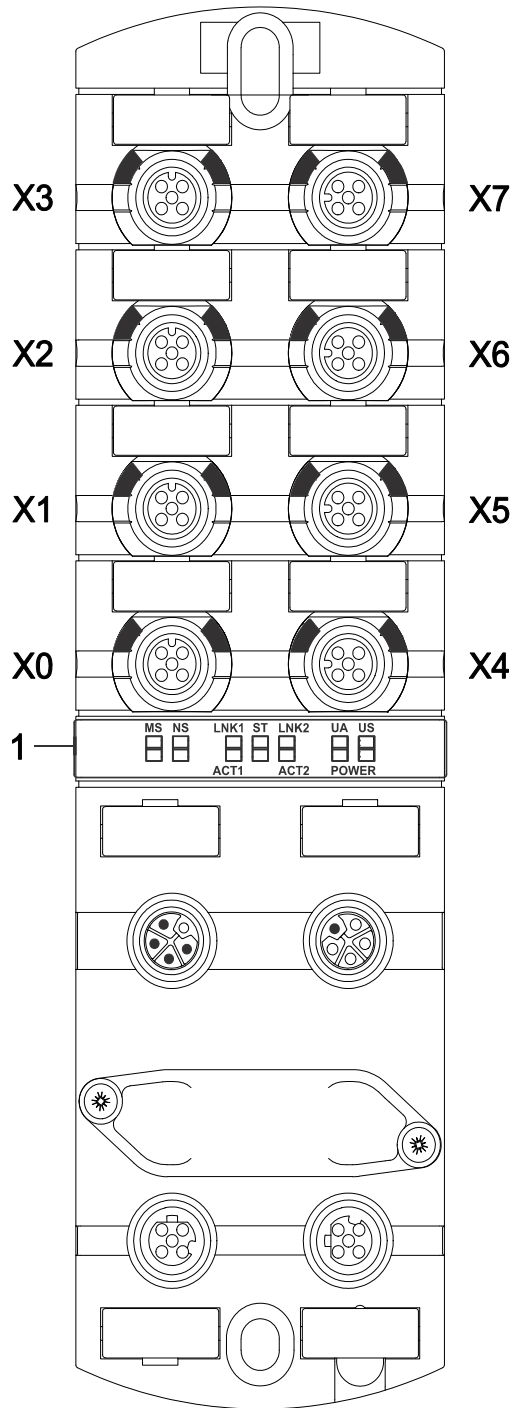

X0–X7 LED digital inputs and outputs or IO-Link

- 1
- LED MS (module configuration status)
  - LED NS (network status)
  - LED LNK1/ACT1 (Ethernet port 1 link/activity)
  - LED ST (module overall status)
  - LED LNK2/ACT2 (Ethernet port 2 link/activity)
  - LED POWER UA (actuator voltage)
  - LED POWER US (operating voltage)

Fig. 3-2: Display elements



## 3.1.5. Rotary switch settings

**NOTE**

In the default state, the rotary switches are set to **000**, DHCP enabled.

**NOTE**

A unique IP address must be assigned to each device in the network.

Setting the IP Address on the Rotary Switches		
x 100	x 10	x 1
		
<b>Address range: 1–999</b>		
x1	Rotary switch (ones)	
x10	Rotary switch (tens)	
x100	Rotary switch (hundreds)	
Position/Range	Description	
0	DHCP	Request the IP addresses via DHCP (can be changed to BOOTP via the WebUI or Explicit Messaging) <ul style="list-style-type: none"> <li>■ After factory reset: DHCP</li> <li>■ The network parameters have been saved previously: The parameters saved last are used.</li> </ul>
1–254	IP address Byte 4	The last octet of the IP address (set via DHCP, WebUI or setting 777) is overwritten by the DIP switch setting and applied. The factory default IP address subnet is <b>192.168.1.xxx</b> . Use of setting 777 changes the subnet to 192.168.100.xxx.
255	Last saved IP address	The IP address saved last is used. (192.168.1.6 by default)
256–776		Reserved
777	Fixed IP	The IP address is set STATIC at 192.168.100.177.
778–912		Reserved
913	Deactivate web server	Disables the web server and TCP port 80. Only the WebUI is disabled.
914	Reactivate web server	WebUI is enabled again.
915–978		Reserved
979	Factory reset	Sequence: 1   Disconnect module from power supply. 2   Set switch position 979. 3   Supply module with power. 4   <b>Wait until SF LED changes from flashing green to solid green.</b> 5   Disconnect module from power. 6   Switch position to 000 or any other desired position. 7   Supply module with power.
980–999		Reserved

**NOTE**

The saved default IP address is 192.168.1.6.

**NOTE**

The IP address parameters are stored for all switch settings. This must be taken into account in particular with the switch setting **0**.

## Setting an address

1. Remove the rotary switch cover.
2. Set the three rotary switches.
3. Carefully replace the rotary switch cover.



The tightening torques can be found in [Section 5.4.2, “Rotary switch cover”](#).

## 3.2. IO-Link

IO-Link is a standardized protocol that enables connection of intelligent devices (sensors and actuators) to an automation system.

Communication takes place between an IO-Link master and one or more IO-Link devices. A master module has one or more ports and one device can be connected to each port. IO-Link is a point-to-point communication system and is not a fieldbus.

The IO-Link master module is the interface between the controller and the IO-Link system.

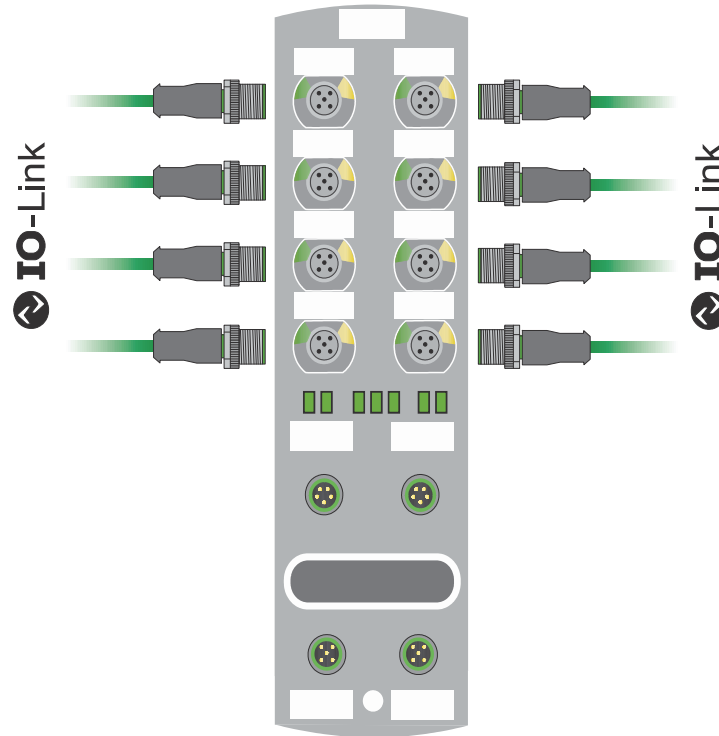

Fig. 3-3: IO-Link

### IO-Link mode (IOL)

IO-Link communication (C/Q) is activated on pin 4 and an IOL device can thus be connected.



For further information, refer to [Section 8.3, "IO-Link configuration"](#).

### 3.2.1. Data storage

**NOTE**

Data storage is only available for devices that comply with IO-Link version V1.1 and higher.

- Data storage offers the ability to replace IO-Link devices without reconfiguration.
- The IO-Link master or the IO-Link device saves the set device parameters of the previous configuration.
- In data storage, the configuration of the IO-Link master and IO-Link device are synchronized.
- Following the replacement of a device, the master writes the saved device configuration to the new device whenever data storage is enabled in the IO-Link master. The application can be restarted without separately configuring the device.
- Following the replacement of an IO-Link master, the device writes the saved device parameters to the new master whenever the “Save & Restore” data storage is enabled in the IO-Link master. The application can be restarted without configuring the new master.

**NOTE**

Data storage can only be implemented using the EDS file. For example, to implement Backup & Restore data storage for an IO-Link device on a given IO-Link port, the port must be setup as follows (see Section 7.4.4 for IO-Link port parameter details):

- Parameter “IO-Link Port X\_ - IO-Link Function Pin 4” must be configured as “IO-Link Manual Configuration”.
- Parameter “IO-Link Port X\_ - Validation&Backup” must be configured as “Type compatible Device V1.1, Backup + Restore”.
- Parameter “IO-Link Port X\_ - Vendor ID” must be configured to match the device.
- Parameter “IO-Link Port X\_ - Device ID” must be configured to match the device.
- Ensure that the EDS configuration parameters are sent to the IO-Link master.
- Make desired configuration changes to the IO-Link device via acyclic ISDU writes. (See Section 9.3 for details on acyclic device access.)
- Send a ParamDownloadStore command to the IO-Link device by writing a value of 5 to index 2. This will set the DS\_UPLOAD\_FLAG in the device which triggers the master IO-Link port to backup the current device configuration.
- If the current device is replaced with a type-compatible device (a device with Vendor and Device IDs matching the port configuration), the IO-Link port will update the new device with the stored configuration from the previous device, as long as the DS\_UPLOAD\_FLAG is not set in the new device.

## 3.3. EtherNet/IP

### 3.3.1. Communication

EtherNet/IP is based on a Producer/Consumer communication model for which the multicast Ethernet communication enables fast “Report by exception” responses.

The connection to the control scanner can only be established in an EtherNet/IP network via 10/100MBit/s Ethernet switches.

**NOTE**

The maximum permissible cable length to the end point without any auxiliary devices is 100m [328ft].

A 2-port switch is integrated into the fieldbus device. This switch sends multicast messages to all switch ports and behaves in this case like a hub. When Unmanaged Switches are used, more multicast users (EtherNet/IP users) are added to the system, resulting in more multicast traffic for the users. Thus, a higher amount of bandwidth is used in the system which results in longer response times as each user must evaluate messages that are not addressed to the user.

Excessive network traffic may result in missed messages and RPI response delays which may interrupt communication.

It is therefore recommended to split the entire network into several segments by means of several switches. By choosing suitable RPI times and switches, high-speed networks can be decoupled from non-time-critical systems.

**NOTE**

A Managed switch should be considered for network segments that include traffic unrelated to the IO-Link segment.

Managed switches are recommended for high-speed control systems. To manage the multicast traffic, the switch must support the IGMP Snooping function (Internet Group Management Protocol). For the connection of a control system to a large plant or company network, consider using a virtual LAN on a switch, or a router.

### Unicast connections

The device is able to establish data connections using Unicast connections. Unicast connections may result in reduced traffic on the network. Please select the best type of connection for your application.

### 3.3.2. RPI

#### Requested Packet Interval (RPI)

When setting up an EtherNet/IP system, the RPI value must be carefully set in the scanner. The RPI value determines the speed at which the scanner sends EtherNet/IP messages (packets). It also determines the maximum speed at which the bus node sends messages.

The scanner sends the RPI when establishing a connection with a bus node so the system uses the same time base. The RPI is also the interval at which the scanner will expect a response. An RPI that is too short will result in increased network traffic.

The system slows as it processes the additional traffic because traffic on the network that is not intended for the IO-Link devices must also be evaluated. The delays may make the system unable to meet the RPI.

The controller will report an error (timeout) if the response time of the device exceeds the set RPI time by a factor of 4.

Please note:

- a | Configurations which require RPI times shorter than 10ms must be tested in advance for correct operation.
- b | The minimum supported RPI time is 1 ms.



For further information, refer to [Section 8.2, “RPI configuration”](#).

### 3.3.3. Device Level Ring (DLR)

#### Device Level Ring (DLR)

Device Level Ring (DLR) is a protocol which allows media redundancy in a ring topology, e.g. for EtherNet/IP™ devices.

A ring network consists of at least one ring supervisor and any desired number of devices.

There are two different methods of building the topology and detecting cable breaks inside the ring:

- a | Beacon-based
- b | Announce-based

Devices which support DLR must have implemented the DLR object (0x47) which details configuration and diagnostic. The use of modules which are not DLR-compliant in an EtherNet/IP ring network is not excluded. However, it results in a higher ring recovery time when the ring topology is interrupted.



#### NOTE

The modules described in this manual support the beacon-based DLR technology. The described modules do not support the ring supervisor function and can not be used as ring supervisor.

## 4. Technical Data

### 4.1. Electrical Data

Functions		
<b>Web Interface</b>	http	Yes
<b>Energy monitoring</b>	Current and voltage	Yes
<b>Temperature monitoring</b>		Yes

Bus Data		
<b>Fieldbus protocol</b>		EtherNet/IP
<b>Ethernet</b>		10/100 Mbit/s
<b>Addressing</b>		BOOTP, DHCP, WebUI, Rotary encoder switch
<b>Connection types</b>		Exclusive Owner, Listen Only, Input Only
<b>Device Level Ring (DLR)</b>		Beacon-based
<b>Connector</b>		M12, 4-pin, D-coded

IO-Link		
<b>IO-Link devices operating voltage</b>		24VDC ---
<b>IO-Link devices voltage range</b>		20–30V
<b>Transfer rate</b>		4.8, 38.4 or 230.4 kbit/s (COM1, COM2, COM3)
<b>Standardized Master Interface (SMI)</b>		IO-Link V1.1.3
<b>Transfer rate recognition</b>		Automatic

Supply		
<b>Operating voltage US</b>		24VDC ---
<b>Voltage range US</b>		18–30V
	When using IO-Link	20.3–30V
<b>Operating voltage UA</b>		24V
<b>Voltage range UA</b>		18–30V
<b>Sensor current US</b>	≤40°C [104°F] (see Derating)	≤16A
<b>Actuator current UA</b>	≤40°C [104°F] (see Derating)	≤16A
<b>Current consumption</b>	At idle	≤0.18 A
<b>Connector</b>		M12, 5-pin, L-coded
<b>Conductor cross-section</b>	Current per supply ≤12A	#14 AWG
	Current per supply >12A	#12 AWG

<b>Input (DI)</b>		
<b>Sensor power supply</b>	Per Port ≤60°C [140°F] (see Derating)	≤1A load Automatic start
<b>Total current Sensor supply</b>	≤40°C [104°F] (see Derating)	≤10A
<b>Filter time</b>		0–15 ms + tcycle, adjustable
<b>Delay time for signal change</b>		2–5 ms
<b>Input characteristic</b>	EN 61131-2	Type 1 + Type 3
<b>Short-circuit protection, sensor supply</b>		MOSFET with current measurement
<b>Connector</b>		M12, 5-pin, A-coded
<b>Conductor cross-section</b>		#18 AWG
<b>Conductor length</b>		≤30m [98ft]
<b>Total current</b>	Per port	≤2A

<b>Output (DO)</b>		
<b>Output current DO (UA)</b>	Per Port ≤60°C [140°F] (see Derating)	≤1A
<b>Total current outputs</b>	≤40°C [104°F] (see Derating)	≤10A
<b>Frequency</b>		≤50Hz
<b>Short-circuit protection actuator</b>		MOSFET with current measurement
<b>Connector</b>		M12, 5-pin, A-coded
<b>Conductor cross-section</b>		#18 AWG
<b>Conductor length</b>		≤30m [98ft]
<b>Total current</b>	Per port	≤2A

Derating Charts

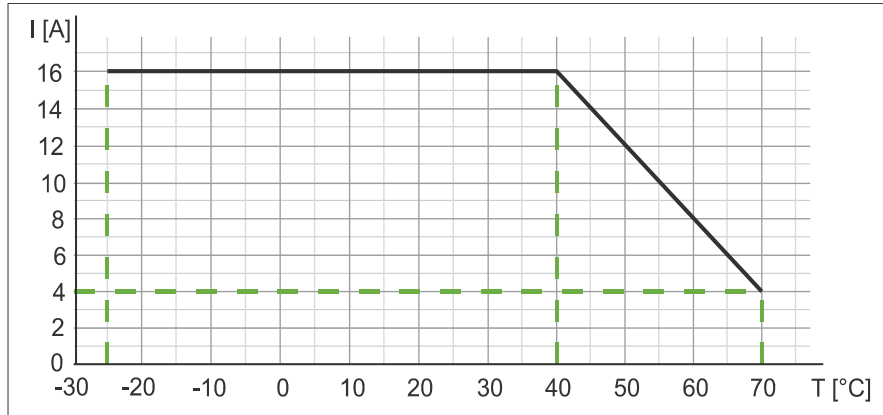

Fig. 4-1: Sensor current US and actuator current UA.

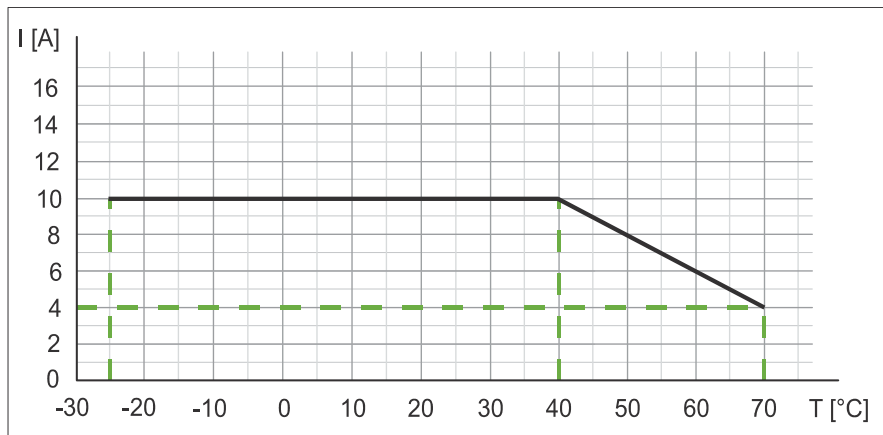

Fig. 4-2: Total current, sensor power supplies Total current, outputs.

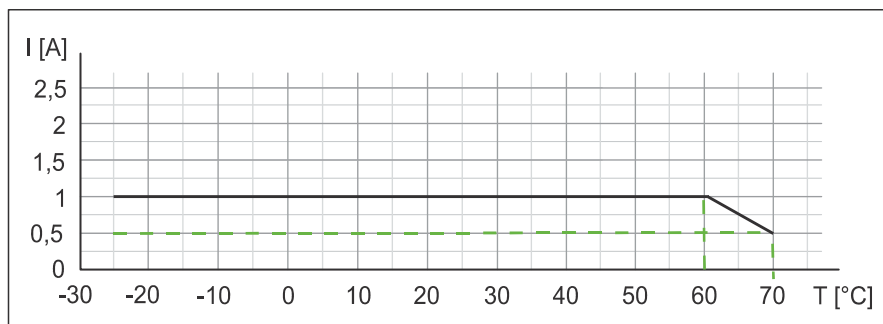

Fig. 4-3: Derating Current per sensor power supply and output.

## 4.2. Environmental characteristics

Environmental		
<b>Operating temperature</b>		-25°C to +70°C [-13°F to +158°F]
<b>Storage temperature</b>	Provide acclimatization for commissioning	-25°C to +85°C [-13°F to +185°F]
<b>Relative humidity</b>		≤95%
<b>Installation height</b>	Above sea level	≤3000m

Mechanical		
<b>Vibration test</b>	EN 60068 Part 2-6	10–58 Hz, Oscillation angle 0.35 mm, 58–150 Hz; 20 g
<b>Shock test</b>	EN 60068 Part 2-27	50 g, duration 11 ms

Electrical Safety		
<b>Radiated interference E-field enclosure</b>	EN 55016-2-3	

EMC Inteference		
<b>Protection degree</b>	EN 60529	IP67
<b>Protection class</b>	Using a SELV- or PELV- power supply	III
<b>Pollution degree</b>		2

EMC Immunity		
<b>Electrostatic discharge (ESD)</b>	EN 61000-4-2	
<b>Electromagnetic RF fields</b>	EN 61000-4-3	
<b>Fast transient burst</b>	EN 61000-4-4	
<b>Surge AC</b>	EN 61000-4-5	
<b>Conducted RF fields</b>	EN 61000-4-6	
<b>Voltage dips</b>	EN 61000-4-11	

## 4.3. Protection

Device Protection		
<b>Overvoltage protection</b>		Yes
<b>Overload protection module supply</b>	To be ensured through load circuit monitoring	Yes
<b>Inverse-polarity protection module supply US and UA</b>		Yes
<b>Short-circuit protection sensor supply</b>		Electronically
<b>Short-circuit protection output</b>		Electronically
<b>Protective circuit input</b>	Internal	Suppressor diode

### 4.4. Mechanical data

Materials		
<b>Housing material</b>		Plastic

Assembly Data		
<b>Weight</b>	Net	470g [16.6 oz]
<b>Dimensions</b>	L x W x H	225.4 x 63 x 36 mm [8.874 x 2.5 x 1.4 in]

### 4.5. Conformity, Approvals

Conformity, Approvals		
<b>Product standard</b>	EN 61131-2 Programmable logic controllers	
<b>CE</b>	2014/30/EU 2011/65/EU	
<b>UKCA</b>		Compliant
<b>EMC</b>	2014/30/EU	
<b>REACH</b>	No. 1907/2006	SVHC List
<b>WEEE</b>	2012/19/EU	Category 5
<b>cUL</b>	CSA C22.2 NO. 61010-1, 3rd Ed., CSA C22.2 NO. 61010-2-201:18, 2nd Ed.	E201820
<b>ULus</b>	UL 61010-1, 3rd Ed.,  UL 61010-2-201, 2nd Ed.	E201820
<b>China RoHS</b>	GB/T 26572	25 EPUP

Hazardous Substances							
 Part Name	Lead (Pb)	Mercury (Hg)	Cadmium (Cd)	Hexavalent Chromium (Cr (VI))	Polybrominated biphenyls (PBB)	Polybrominated diphenyl ethers (PBDE)	
<b>Component part PCB</b>	X	O	O	O	O	O	
<b>Connection Terminal/Screws</b>	X	O	O	O	O	O	

O: Indicates that the content of the harmful substance in all homogeneous materials of the component part is below the limit defined in GB/T 26572.  
X: Indicates that the content of the harmful substance in at least one homogeneous material of the component part exceeds the limit defined in GB/T 26572.

## 5. Mounting

### 5.1. Requirements

- Mount on a flat mounting surface to avoid mechanical tension.
- Provide suitable grounding.
- Select a suitable installation site in terms of vibration and shock load, temperature and humidity (see [Section 4, "Technical Data"](#)).
- Protect connections to avoid stress to connectors or cables by personnel or device.

### 5.2. Dimensions

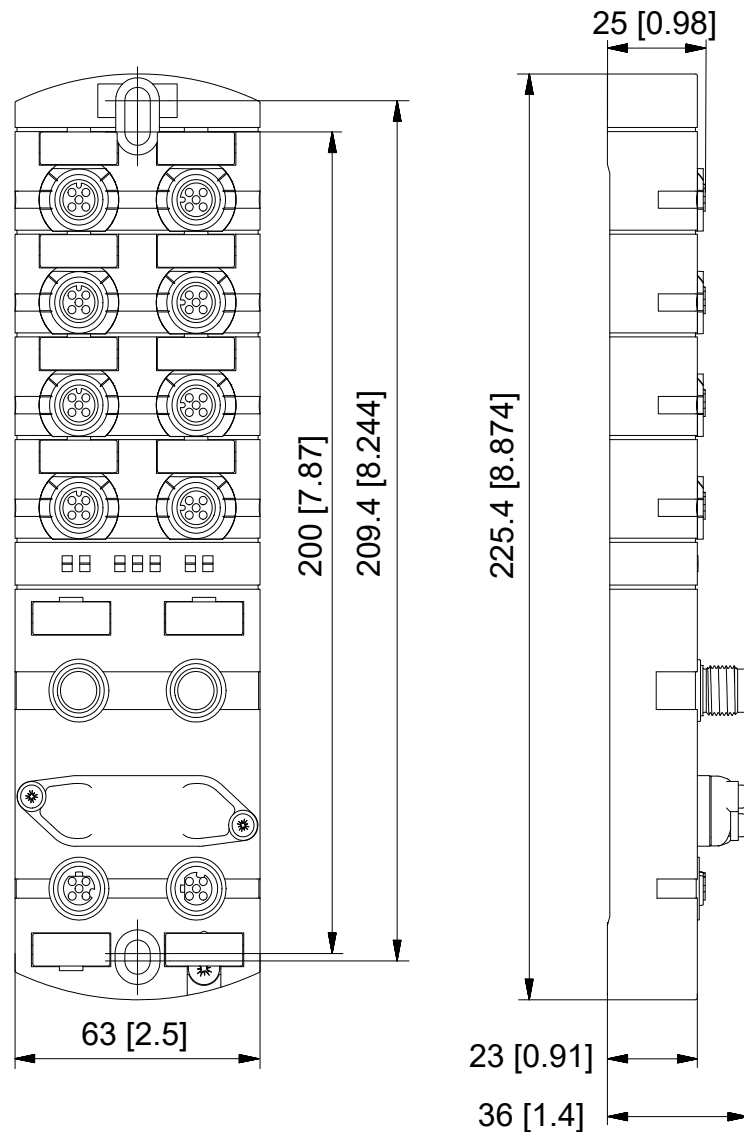

Fig. 5-1: Dimensions, mm [in].

### 5.3. Mounting clearance

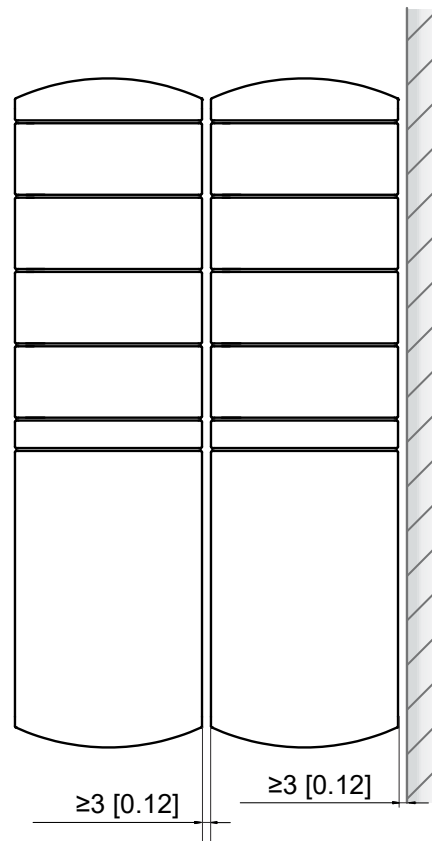

Fig. 5-2: Mounting clearance, mm [in].

**NOTE**

- For correct installation and improved heat dissipation, we recommend keeping a minimum distance of 3mm [0.12 in] when mounting the STRIDE IO-Link master.

**NOTE**

- If angled male connectors are used, a minimum distance of 50mm [2in] is required.

## 5.4. Mounting the module

### NOTICE

#### Material damage due to incorrect installation

The fastening screws and tightening torques depend on the surface of the installation site.

- Use fastening screws that are suitable for the mounting surface structure!
- Carefully tighten the screws! The indicated tightening torques must be adhered to.

### NOTICE

#### Material damage through improper use

Do not use the modules as climbing aids. Improper use can cause the modules to break off or to be damaged otherwise

- Install the modules in such a way that they cannot be used as climbing aid!

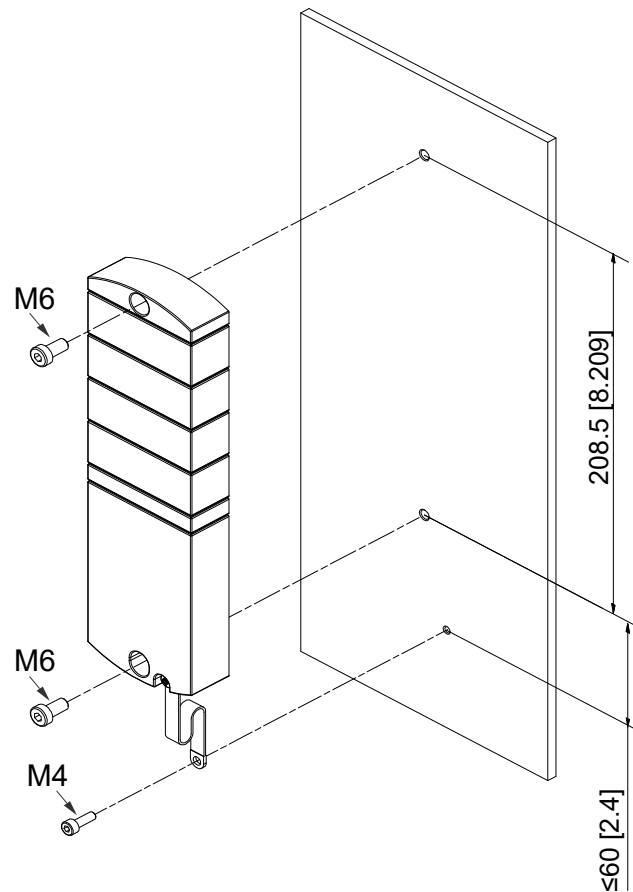



Fig. 5-3: Fasten module. Dimensions in mm [in] (figure similar)

Screw Size	Torque	Tool Required
M6	3 N·m [26 in·lb]	 Phillips Screwdriver, Part # <a href="#">TW-SD-PH-2</a>

Mounting

Mount the module in the order indicated below:

1. Slightly tighten the top M6 bolt.
2. Align housing.
3. Slightly tighten the lower M6 bolt.
4. Tighten screws M6 according to the torque.
5. Ground the module. Attach the grounding strap as shown in [Section 5.4.1, “Functional ground”](#).



**NOTE**  
The screws and the grounding strap illustrated are not included with the device.

5.4.1. Functional ground

With grounding strap



**NOTE**  
Use a conductive screw to attach the grounding strap.

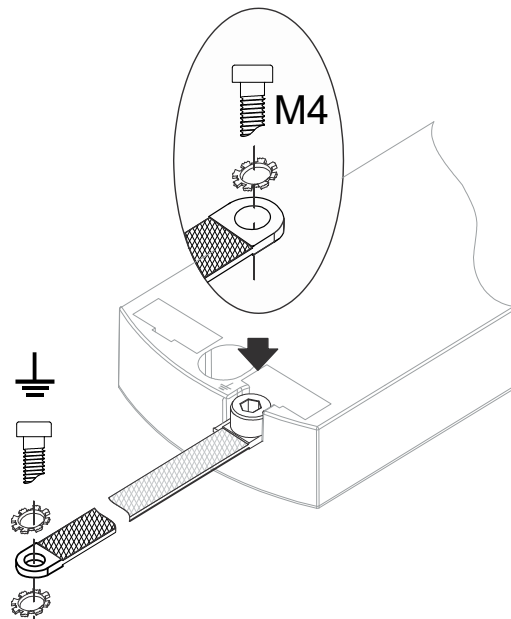



Fig. 5-4: Attachment the grounding strap.

Screw Size	Torque	Tool Required	
M4	1.2 N·m [11 in·lb]		Phillips Screwdriver, Part # <a href="#">TW-SD-PH-2</a>

5.4.2. Rotary switch cover

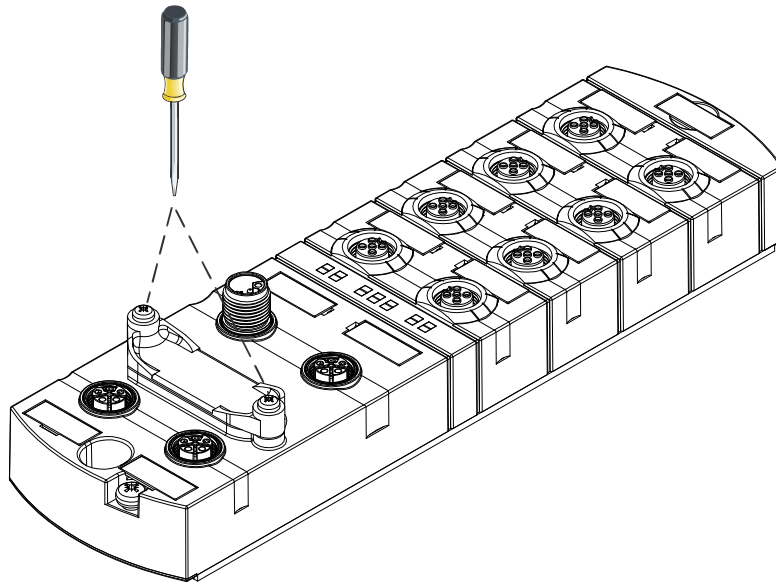



Fig. 5-5: Rotary switch cover installation/removal.

Screw Size	Torque	Tool Required
M3	0.8 N·m [7 in·lb]	 Phillips Screwdriver, Part # <a href="#">TW-SD-PH-1</a>

## 6. Installation

### 6.1. Electrical Installation of the Module

**⚠ WARNING!****Danger due to electric voltage in the machine / system.**

Electrical voltage in the system may result in death or fatal injuries.

- Observe all applicable safety requirements and recommendations.
- Properly connect the module to the electrical system.

**⚠ WARNING!****Risk of fire due to short circuit!**

Damaged supply lines and/or modules may short circuit when damaged which may result in overheating and fire.

- Provide intelligent current monitoring or fuse. The fuse must be designed for max. 9 amps.

**⚠ CAUTION!****Loss of function!**

- Only install cables and accessories that meet the requirements and regulations for safety, electromagnetic compatibility and, if required, telecommunication terminal equipment specifications as well as the specification data.

**⚠ CAUTION!****Hot surface!**

Minor injuries and damage to devices may be caused by contact with the surface.

- Wear thermally suitable gloves.
- Use thermally suitable connecting cables only.

**NOTICE****Damage to the machine/system due to improper switching on of the voltage sources**

When the module is switched on with separate actuator and sensor voltage, the function of the digital inputs and outputs cannot be guaranteed unless the proper power-on order is performed.

- Always switch on voltage sources in the following order:
  1. Switch on sensor voltage.
  2. Switch on actuator voltage.

**NOTE**

Use only a power supply unit that allows max. 60VDC or 25VAC under single-fault conditions. The power supply must comply with SELV or PELV.

### 6.1.1. Connecting sensors and actuators

#### Connecting the M12 ports

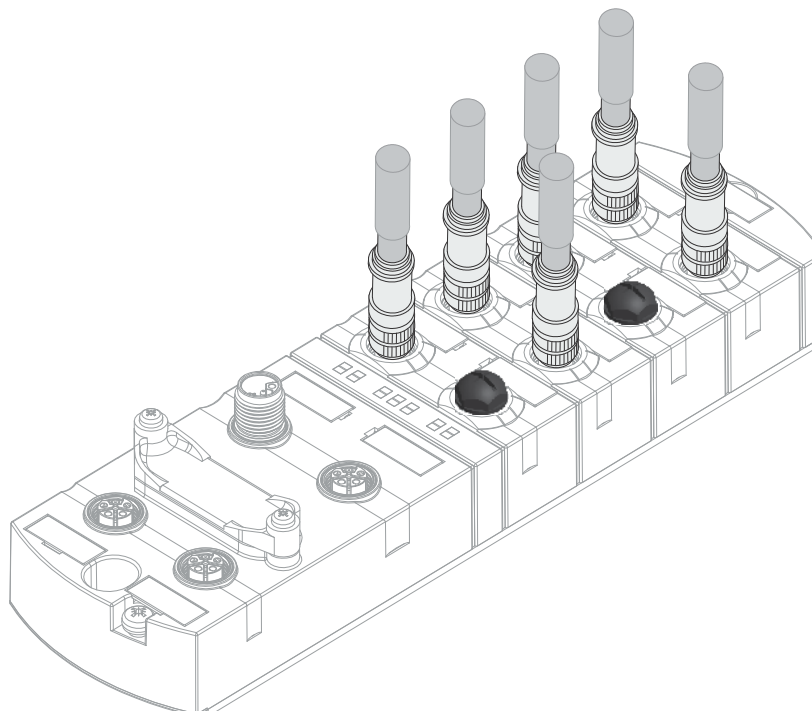
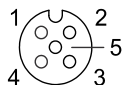

Fig. 6-1: Example of M12 connection inputs and outputs.

Screw Size	Torque	Tool Required
M12	0.6 N·m [5 in·lb]	M12 Torque Wrench



The pin assignment of the slots can be found in [Section 3.1.3, “Connections”](#).



**NOTE**

Feeding in an external ground via M12 female connectors can lead to faults.

→ Do not feed external ground to the module via M12 female connectors.



**NOTE**

Maximum cable length of the sensor and actuator cables is limited to 30m [98ft].

### Sensor power supply

**Please note:**

- Sensors can be supplied via **pin 1** (24V) and **pin 3** (0V) of the M12 female connectors.
- The maximum permissible current for the power supply of the sensors is **1A** for the digital I/O port and **1A** for the IO-Link port.
- In case of overcurrent or short circuit, the connected cable or sensor must be **disconnected** from the M12 female connector.

### Supported IO-Link communication

The module supports the IO-Link communication using the following speeds:

- 4,800 baud (COM 1)
- 38,400 baud (COM 2)
- 230,400 baud (COM 3)



**NOTE**

The module automatically selects the appropriate communication speed for the IO-Link device.



**NOTE**

Maximum cable length is limited to 20m [66ft] for IO-Link connection.

### 6.1.2. Connecting Ethernet bus

#### Connecting the M12 ports

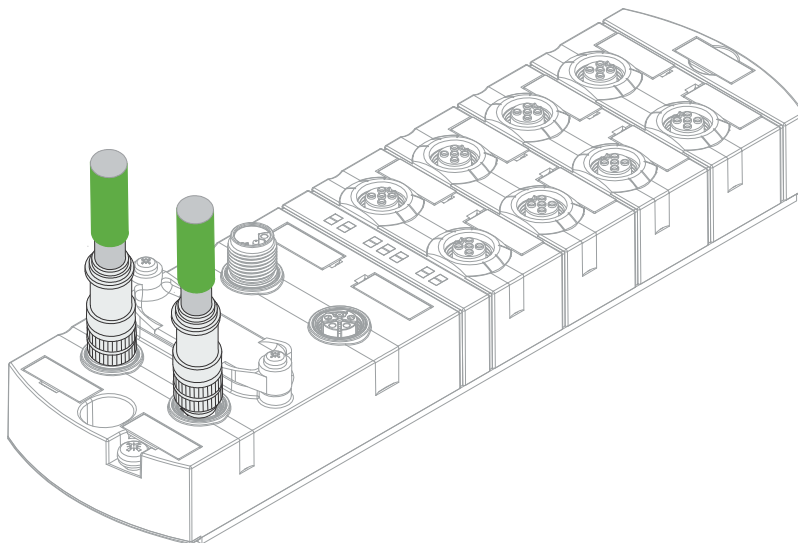
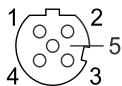

Fig. 6-2: Example of M12 connection (Ethernet bus).

Screw Size	Torque	Tool Required
M12	0.6 N·m [5 in·lb]	M12 Torque Wrench



The pin assignment of the slots can be found in [Section 3.1.3, "Connections"](#).

### 6.1.3. Connecting the power supply

Connect M12 male connector to POWER IN

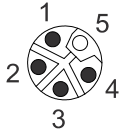

and M12 female connector to POWER OUT

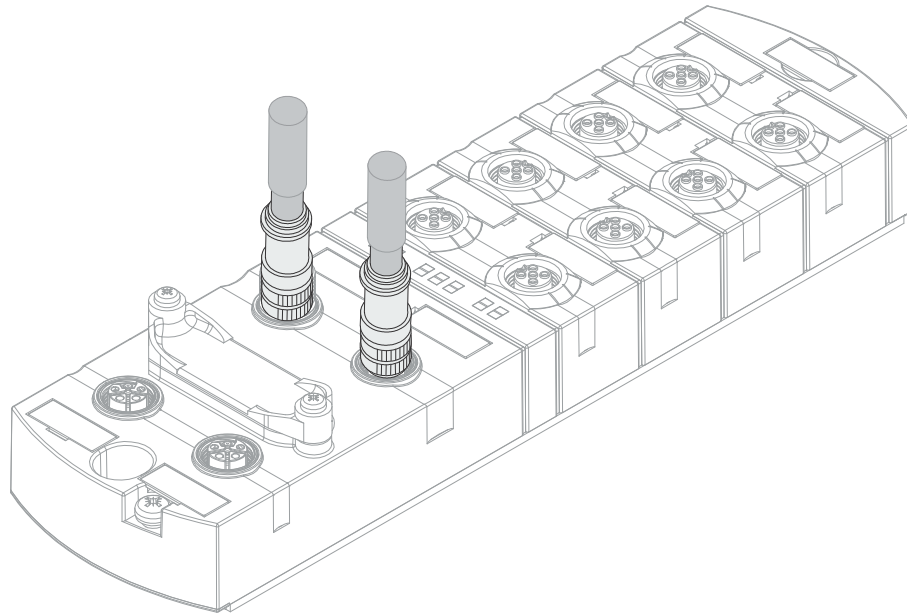
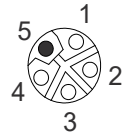

Fig. 6-3: Example of M12 connection (Power).

Screw Size	Torque	Tool Required
M12	0.6 N·m [5 in·lb]	M12 Torque Wrench



The pin assignment of the slots can be found in [Section 3.1.3, “Connections”](#).

## 6.2. Ensuring Tightness (IP67)



### ⚠ CAUTION!

#### Not properly sealed!

Risk of personal injury and material damage due to failure caused by ingress of conductive liquids.

→ Unused male and female connectors must be sealed.

### Connection of cables

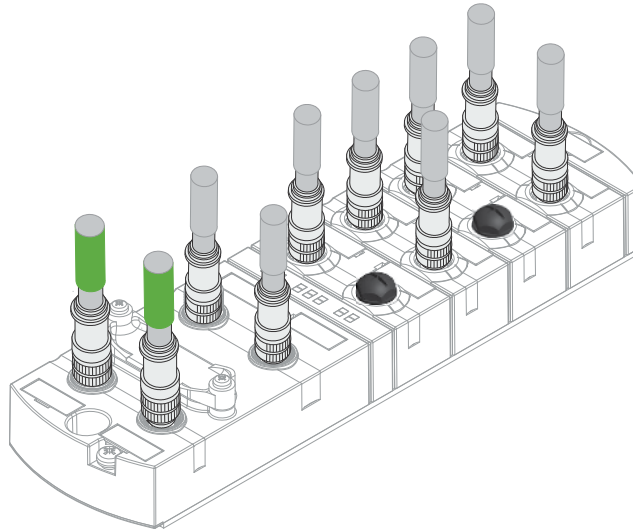

Fig. 6-4: Connection of cables.

## 7. Startup



### ⚠ CAUTION!

#### Uncontrolled processes

Personal injury and material damage due to incorrectly performed start-up phases (e.g. first start-up, restart and configuration changes).

- Always perform the start-up in this sequence:
1. Mount and connect cables to the module.
  2. System check and approval by an expert.
  3. Put it into operation.

### NOTICE

#### Functional errors in residential areas

Devices of EMC Class A may cause interference in residential areas.

- The system operator must take appropriate measures.

## 7.1. Loading the EDS files

This section describes how to configure a module, using Productivity Suite from AutomationDirect.com.

The Stride Basic IO-Link Master can be used with EtherNet/IP scanners capable of Class 1 I/O Messaging (Implicit). Below, we show how to quickly get started using any EtherNet/IP capable Productivity PLC.

1. Download the IO-Link Master EDS file from AutomationDirect.com
2. Open Productivity Suite and start a new project, or open an existing project, and go to **Hardware Config**.

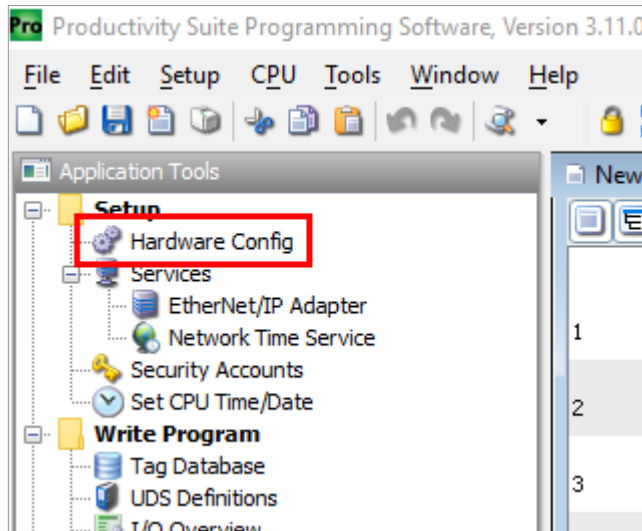

Fig. 7-1: Open Hardware Config.

3. Navigate to the **EtherNet/IP** tab and click **Import EDS File**. Note: If your EDS library already has the SIOL-EI8B part available, you can skip steps 3 and 4.

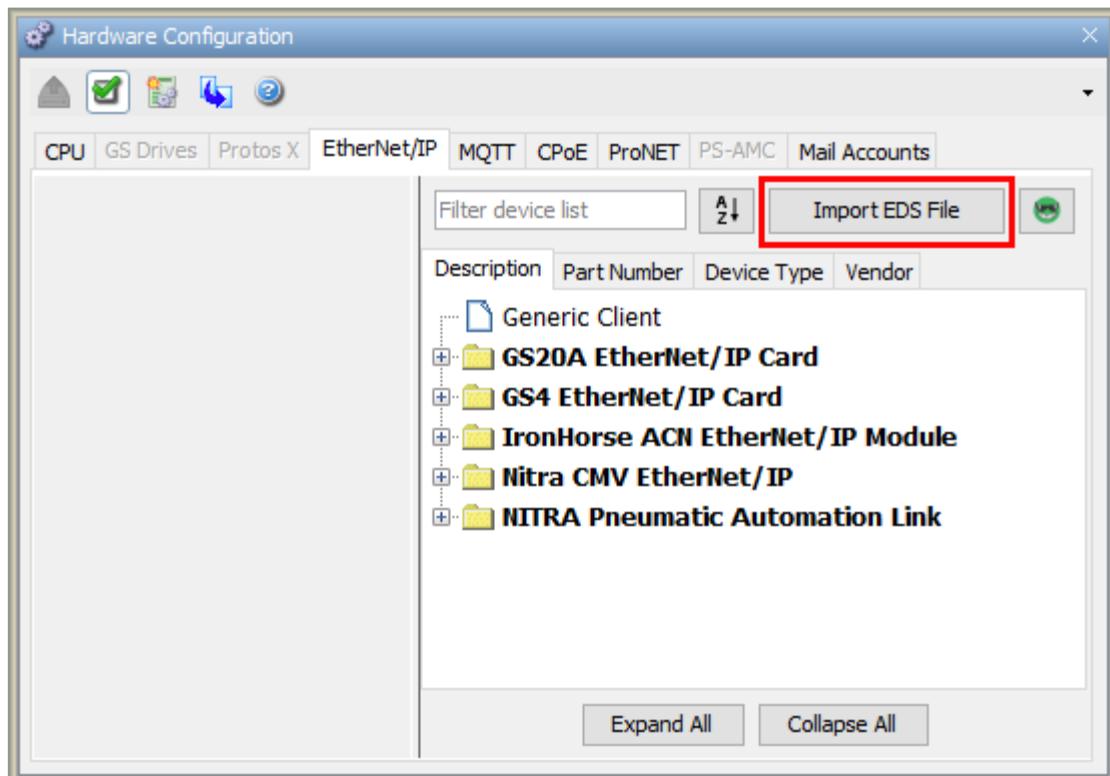

Fig. 7-2: Hardware Config - Import EDS File.

4. Navigate to your download location and double-click the EDS file you downloaded for your IO-Link Master. The EDS file will be added to your EDS library and is now searchable by Description, Part Number, Device Type, or Vendor.

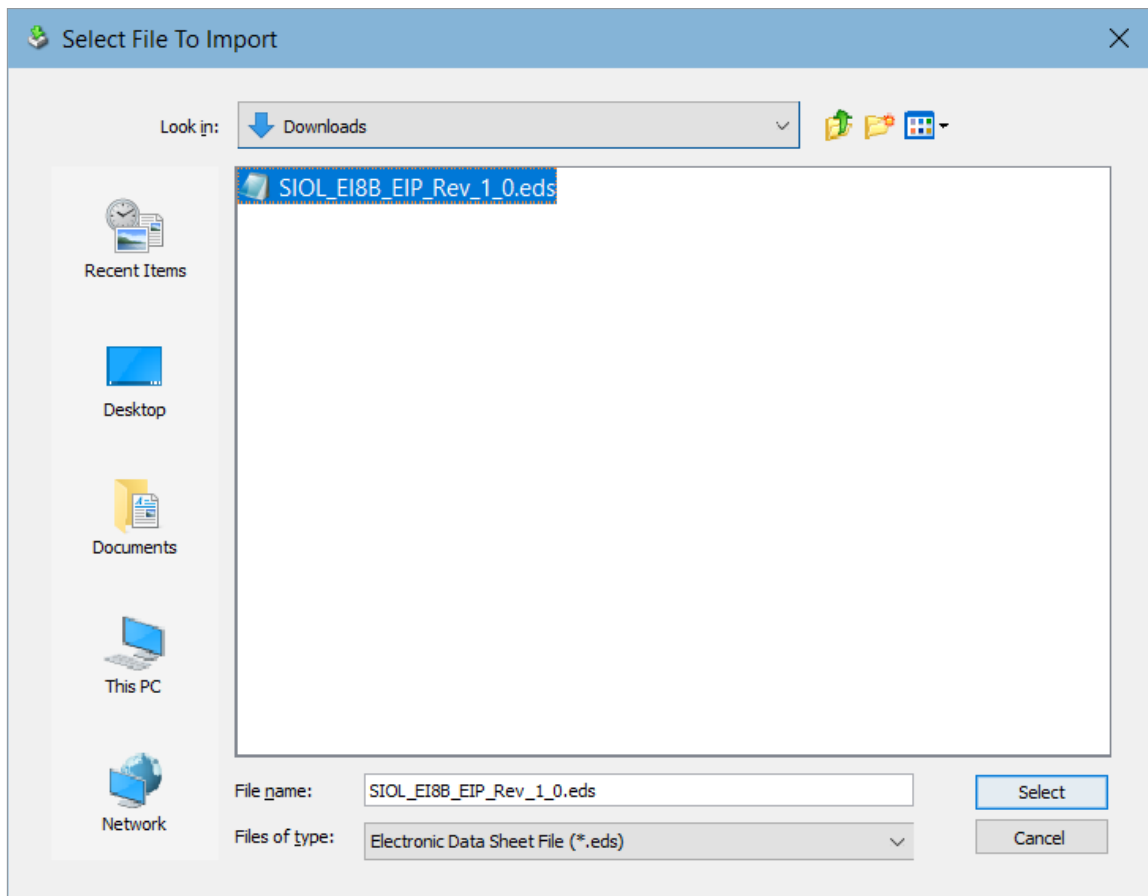

Fig. 7-3: Select EDS File.

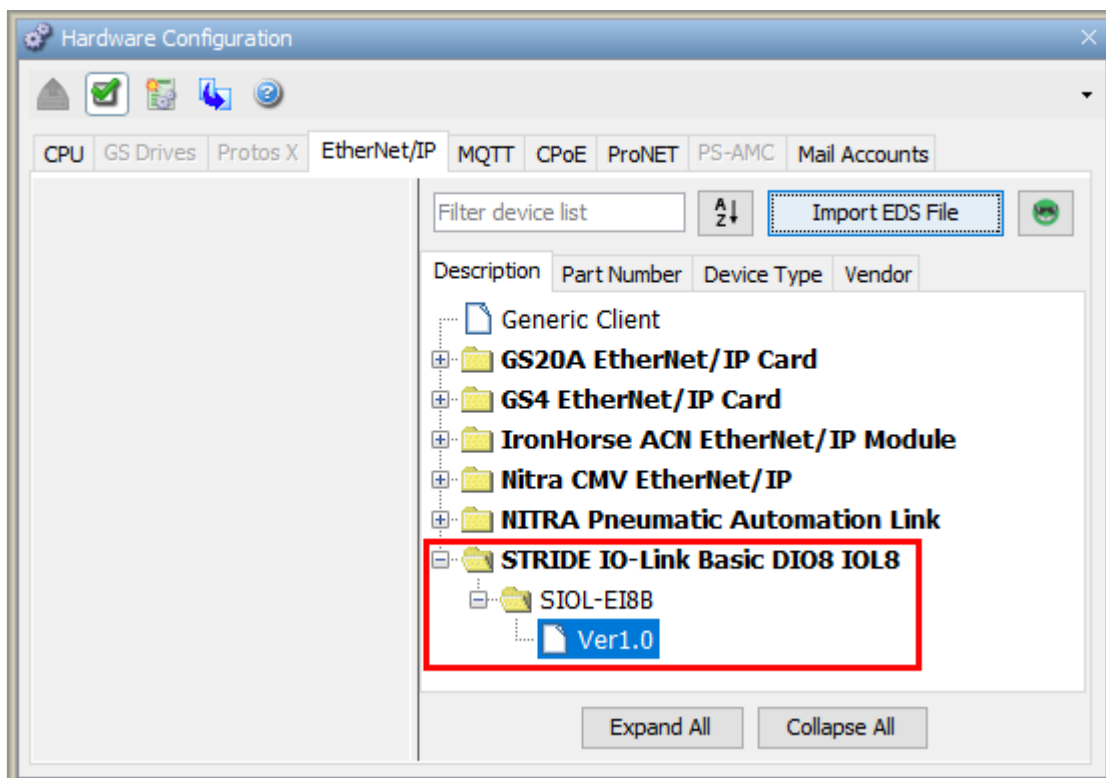

Fig. 7-4: Hardware Config - EDS Library.

## 7.2. Adding a module as an EtherNet/IP Device

Now that the EDS file has been imported and is in the EDS Library, you can add the module as an EtherNet/IP Device from the EtherNet/IP tab of the Hardware Config.



### NOTE

AutomationDirect.com has created quick start code that can be imported into the task library and used to connect to the module. Code has also been developed for communicating with a variety of IO-Link field devices via the IO-Link Master module. To use the quick start code, go to [Section 7.3, “Quick start IO-Link Productivity Code”](#). Otherwise, follow steps 1 through 7 below to add the IO-Link Master module as an EtherNet/IP Device.

1. Double-click or drag the new entry to the device area underneath the hardware tabs.

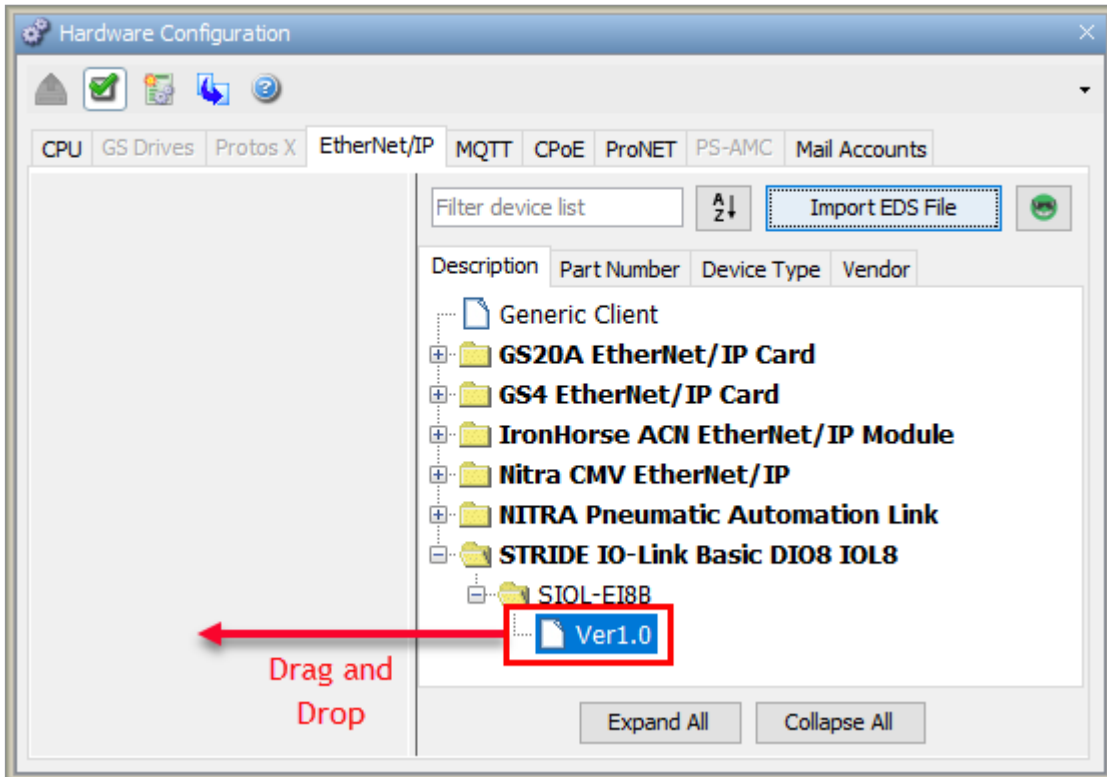

Fig. 7-5: Hardware Config – Drag and Drop new EtherNet/IP Device.

2. Enter tag names for the required elements in your EtherNet/IP device and its IP address, using Structure to organize tags, if desired.

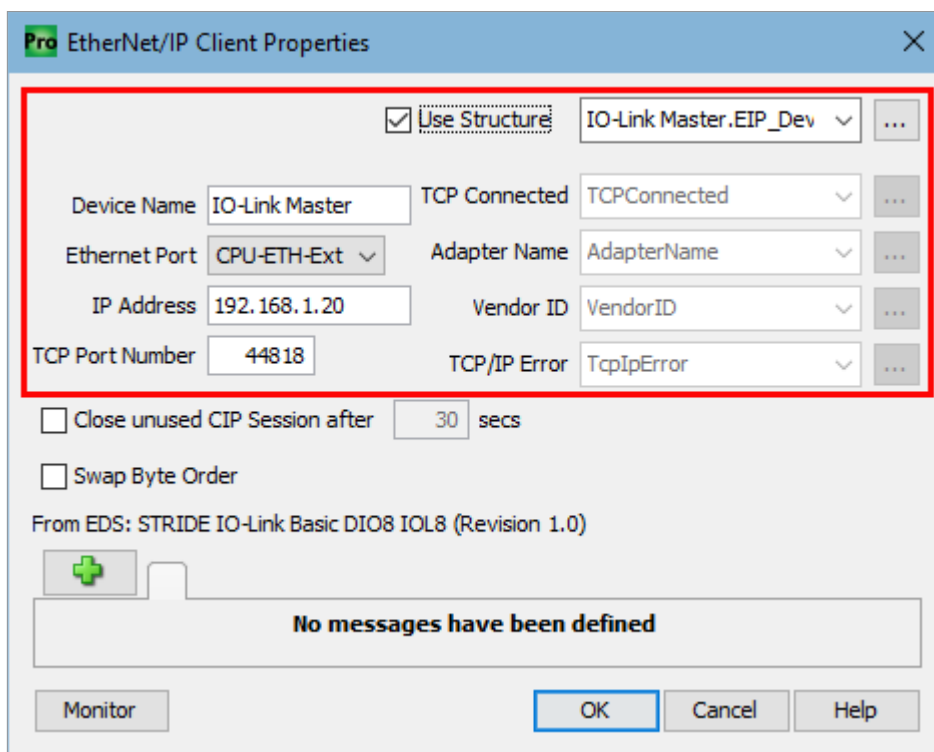



Fig. 7-6: EtherNet/IP Device Configuration.

- Click the  icon to add a new EtherNet/IP message. A list of available connections will be displayed. The appropriate selection will depend on the connected IO-Link devices. For this example, we have selected the 'Exclusive Owner (32B)' Message.

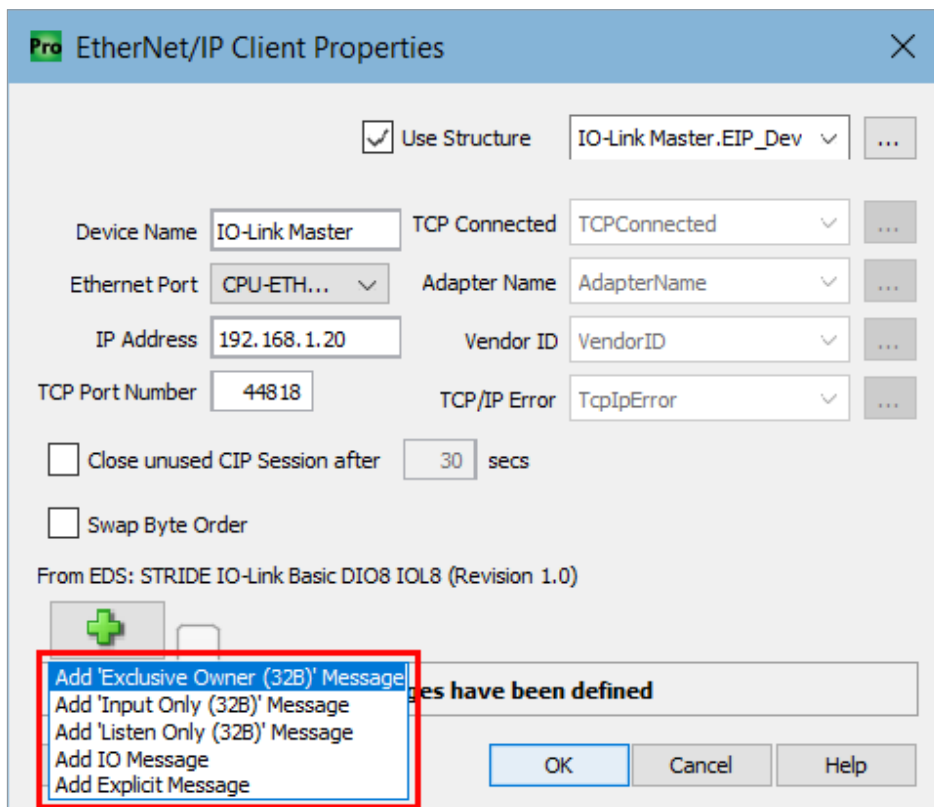

Fig. 7-7: EtherNet/IP Device Message Options.

- Specify a data array for both the **T->O (INPUT)** and **O->T (OUTPUT)** tabs. The required size of each array will depend on the selected Connection from step 3. Specify an integer tag for the Extended Status fields (not required).

**EtherNet/IP Client Properties**

Use Structure IO-Link Master.EIP\_Dev

Device Name: IO-Link Master

Ethernet Port: CPU-ETH...

IP Address: 192.168.1.20

TCP Port Number: 44818

Close unused CIP Session after 30 secs

Swap Byte Order

From EDS: STRIDE IO-Link Basic DIO8 IOL8 (Revision 1.0)

Exclusive Owner (32B)(1)

Enable: Msg1Enable

Application Type:  Exclusive Owner  Input Only / Listen Only

Enable Routing Slot Number: 0

Connection Online: Msg1ConnOnline

General Status: Msg1GenStatus

Extended Status: **IO-Link Master.EIP\_Dev**

Status Description: Msg1SStatusDesc

**T->O (INPUT)** | O->T (OUTPUT) | CONFIG DATA

Target To Originator (INPUT) Data

Include Run/Idle Header (When checked the message size will be increased by 4 bytes)

Delivery Option: Multi...

RPI Time (msec): 250 (10 - 3000)

Run/Idle Status: Msg1RunIdleStatus

Assembly Instance/Connection Point: 101 0x65 (101 - 101)

Specified Message Size Range: (394, 394) Show EDS Parameters

**Message Size from Array (bytes): 394**

Datatype: Integer, 8 Bit Unsigned, 1D Array

Data Array: IO-Link Master.Cyclic\_Ir (394 elements)

Number of Elements: 394

Monitor OK Cancel Help

Fig. 7-8: EtherNet/IP Device T->O Configuration.

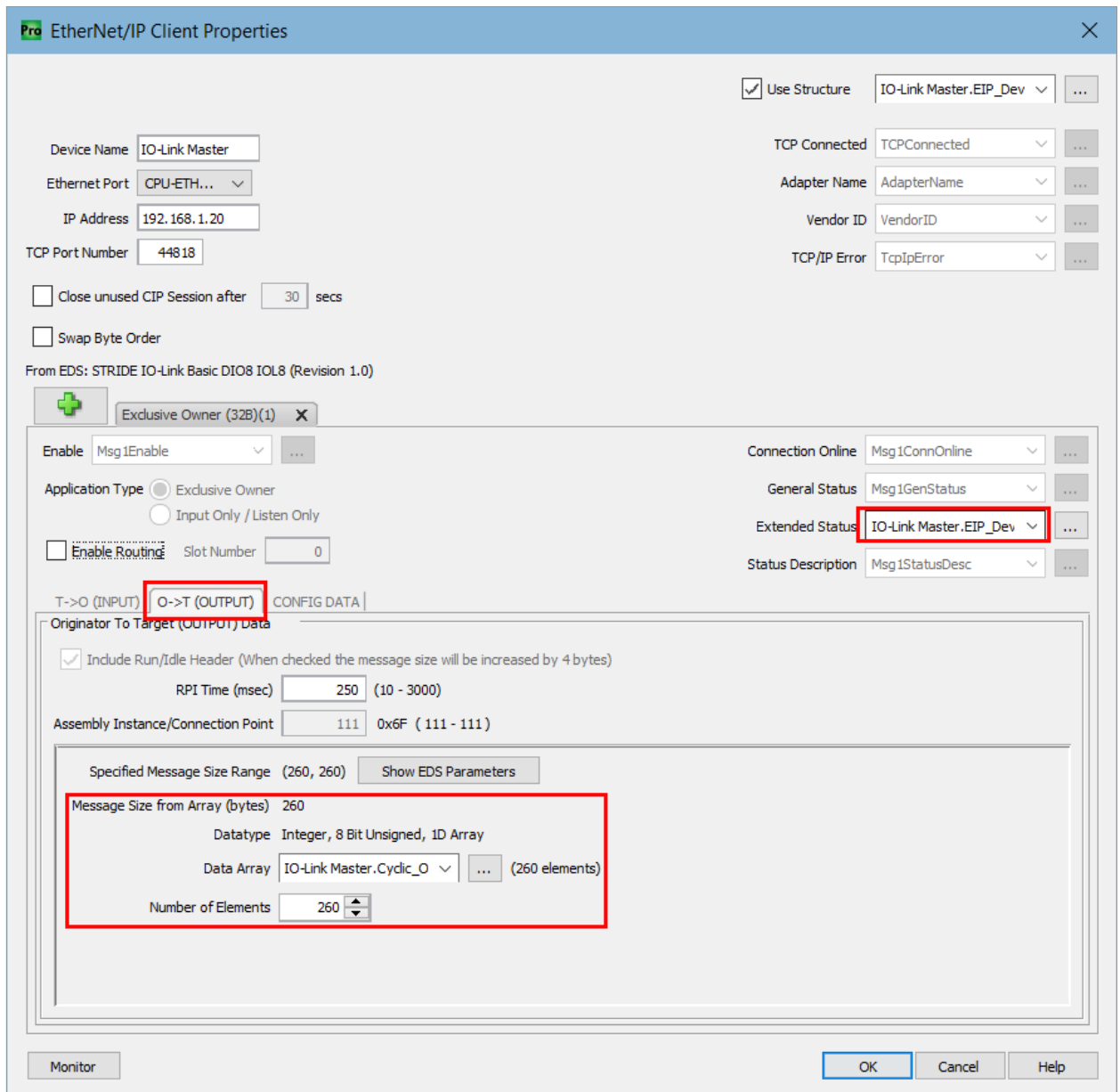

Fig. 7-9: EtherNet/IP Device O->T Configuration.

The input and output tags created for T->O and O->T data can be found in the tag database (see the example in Fig. 7-10).

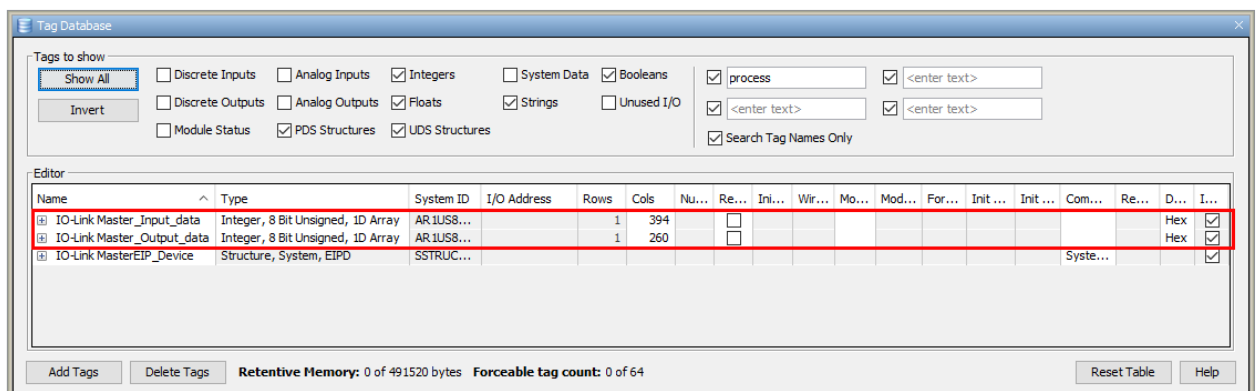

Fig. 7-10: Tag Database – IO-Link Master Input and Output data tags.

5. Select the **Config Data** tab and modify parameters as needed.

**EtherNet/IP Client Properties**

Use Structure IO-Link Master.EIP\_Dev ...

Device Name: IO-Link Master

Ethernet Port: CPU-ETH...

IP Address: 192.168.1.20

TCP Port Number: 44818

Close unused CIP Session after 30 secs

Swap Byte Order

From EDS: STRIDE IO-Link Basic DIO8 IOL8 (Revision 1.0)

Exclusive Owner (32B)(1) X

Enable: Msg1Enable ...

Application Type:  Exclusive Owner  Input Only / Listen Only

Enable Routing Slot Number: 0

T->O (INPUT) | O->T (OUTPUT) | **CONFIG DATA**

Configuration Data

Enable Configuration Data

Assembly Instance/Connection Point: 170 0xAA (170 - 170)

Array Tag  Parameter Table

Message Size (bytes): 384 (Message size is fixed by EDS)

Name	Data Type	Bits[Start] (Range)	Offset Bit (Byte)	Value
Pin/Port based IO layout for digital channels	Integer, 8 Bit Unsigned	8 (0, 1)	1 (1)	Port based
<Padding>		8	1 (2)	
Diag-Param - Global Diagnostic Report	Integer, 8 Bit Unsigned	8 (0, 1)	1 (3)	Global Diagnostic Reporting Enabled
Diag-Param - Under Voltage Sensor Supply...	Integer, 8 Bit Unsigned	8 (0, 1)	1 (4)	Report
<Fixed Value>		16 (17500, 17500)	1 (5)	17500
Diag-Param - Under Voltage Actuator Supp...	Integer, 8 Bit Unsigned	8 (0, 1)	1 (7)	Report
<Fixed Value>		16 (17500, 17500)	1 (8)	17500

Monitor

Fig. 7-11: EtherNet/IP Device Config Data.

6. When configured as desired, click **OK**. The **Hardware Configuration** window will now have the new EIP device that you just configured for the IO-Link Master.

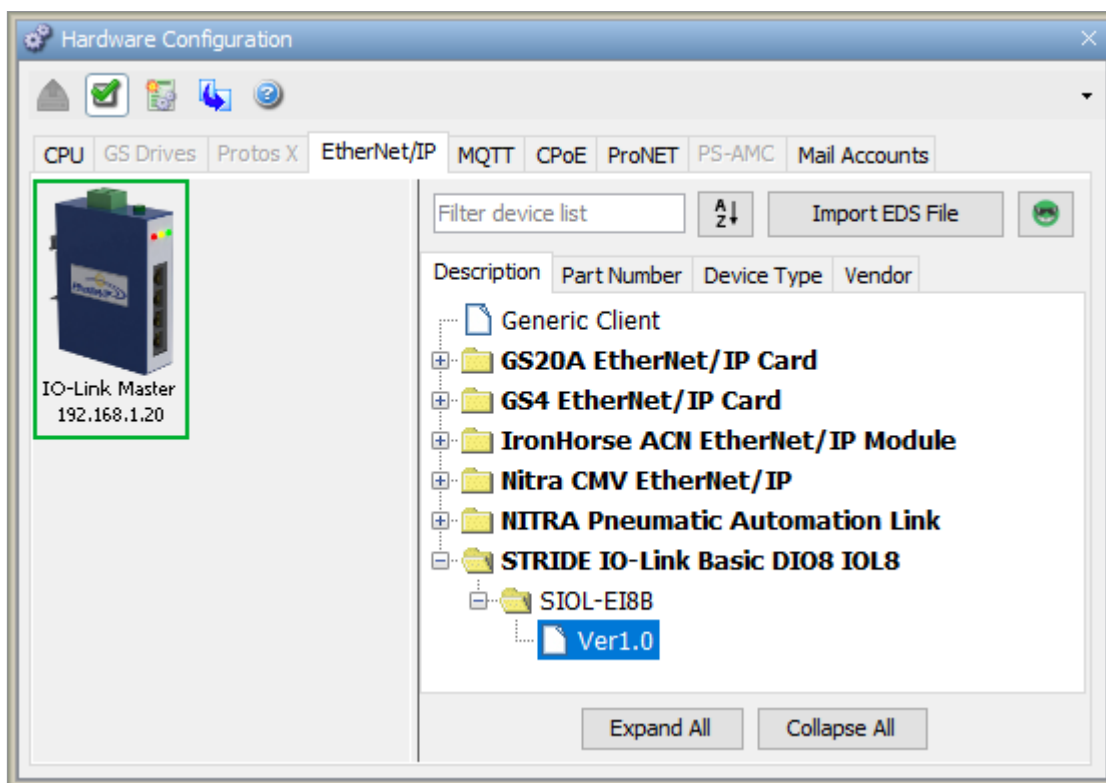

Fig. 7-12: Hardware Config – New EtherNet/IP Device.

7. Your IO-Link Master is now configured. Once you send the program to your PLC, EtherNet/IP communication can be established by setting the first message's Enable bit high (Boolean tag "EIP IO-Link Master.Msg1Enable" in this example) using either ladder code or by editing the tag in data view (Note: you must be online with the CPU to do this).

### 7.3. Productivity Suite Integration Library

AutomationDirect.com has created quick start code that can be imported into the task library and used to connect to the module. Code has also been developed for communicating with a variety of IO-Link field devices via the IO-Link Master module. Follow the steps below to import and setup the quick start code and begin using the module.

1. After opening Productivity Suite and starting a new project, or opening an existing project, import the IO-Link Master EDS file by following the steps in Section 7.1.
2. Download the quick start code from AutomationDirect.com
3. Go to **Task Library**, right click, and select **Import Group**.

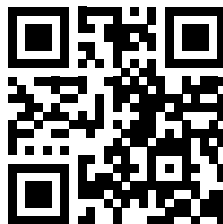

[go2adc.com/iolink](https://go2adc.com/iolink)

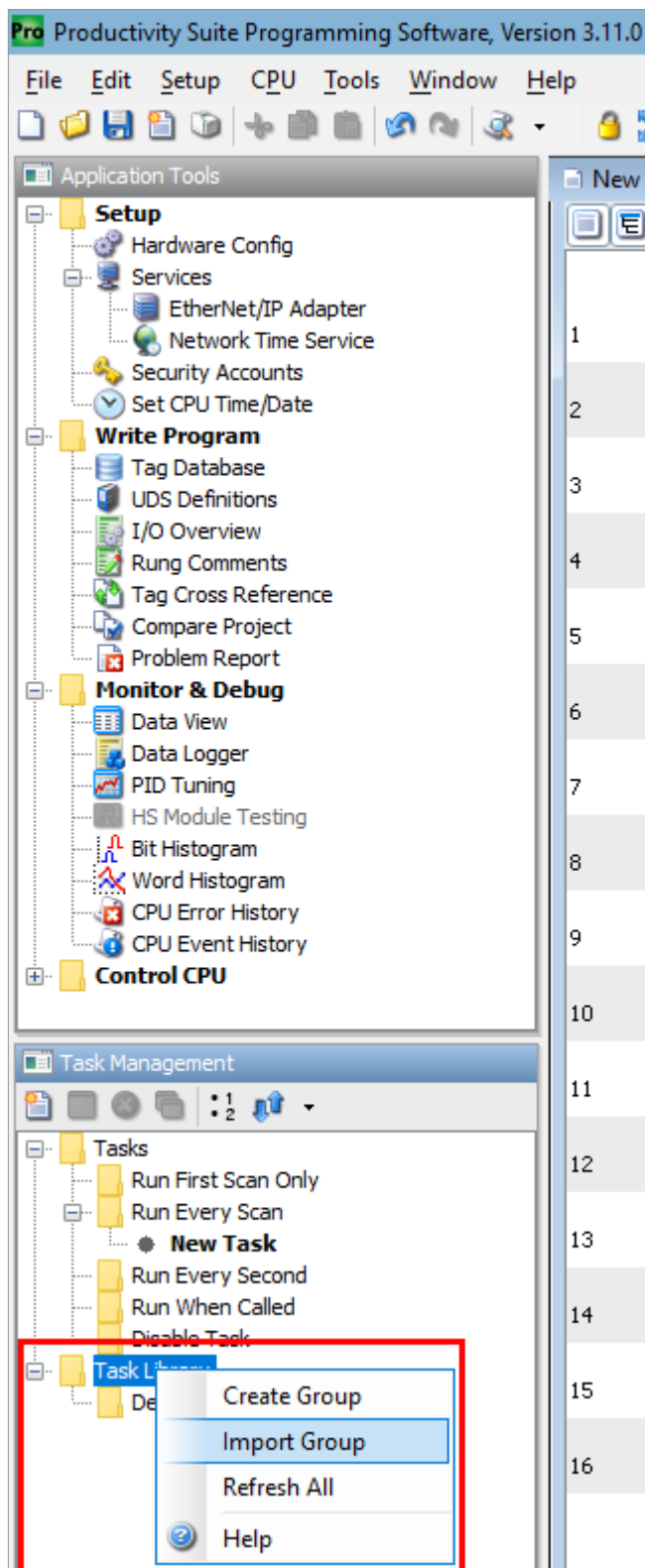

Fig. 7-13: Task Library – Import Group.

4. Navigate to your download location, select the “Stride & Murr IO-Link\_Masters.adtkl” file you downloaded for your IO-Link Master, and click **Import**. The Stride & Murr IO-Link\_Masters group will be added to your Task Library.

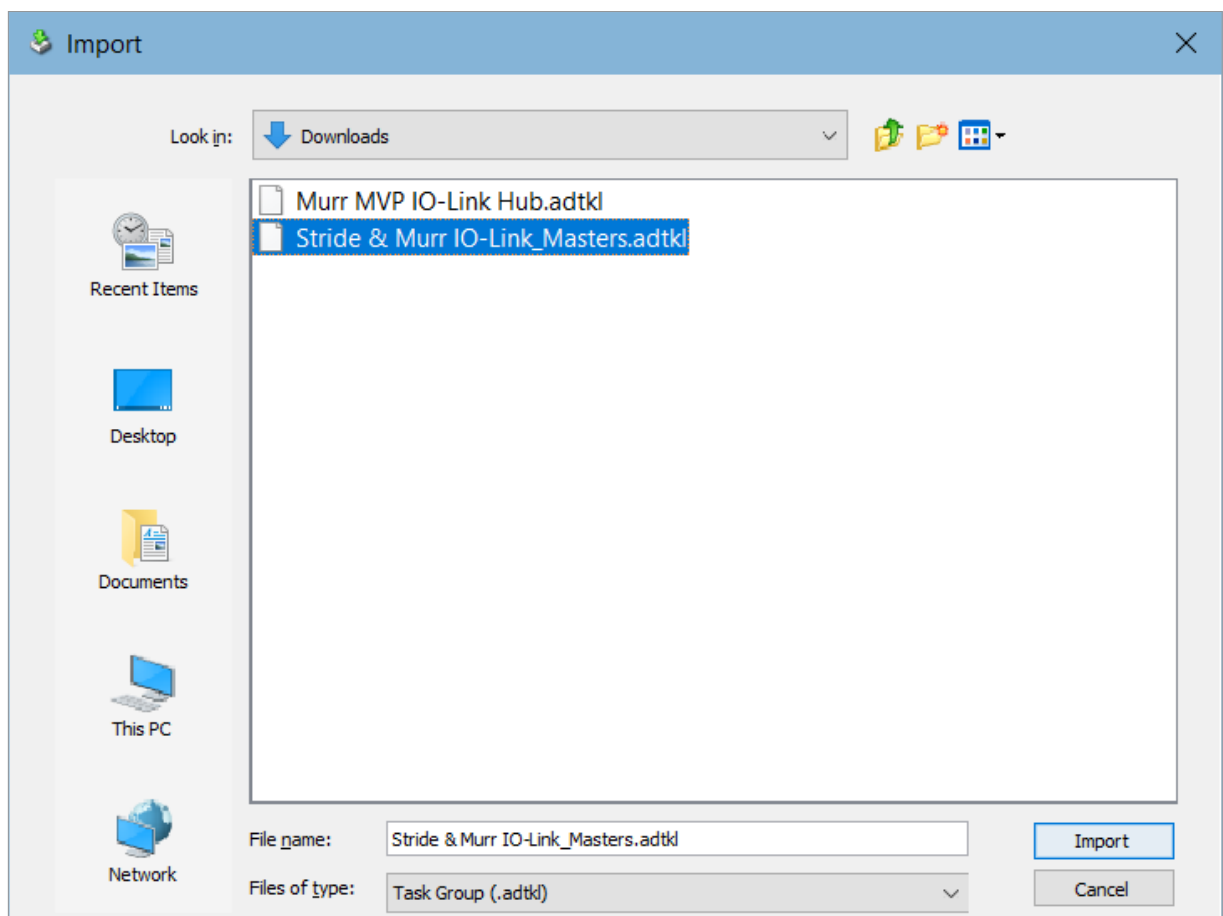

Fig. 7-14: Import Group – Stride & Murr IO-Link\_Masters.adtkl.

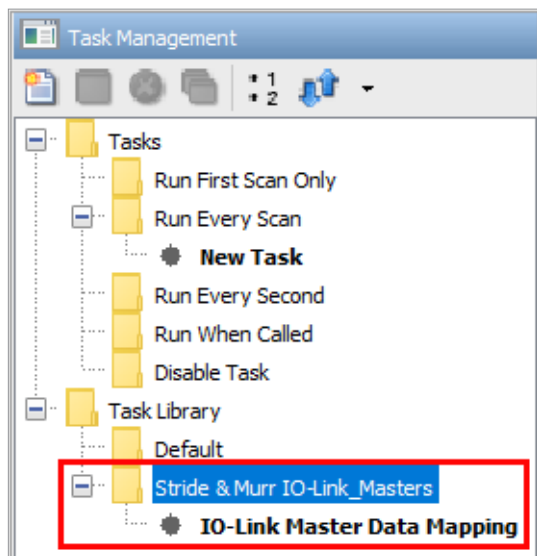

Fig. 7-15: Task Library – IO-Link Master Group.

5. Drag the new task from the Task Library into the **Run Every Scan** task folder and click **OK** on the **Tag Conversion** pop-up. The new task and associated tags have now been created. The next step is to create the EtherNet/IP Device for the IO-Link Master module in hardware configuration.

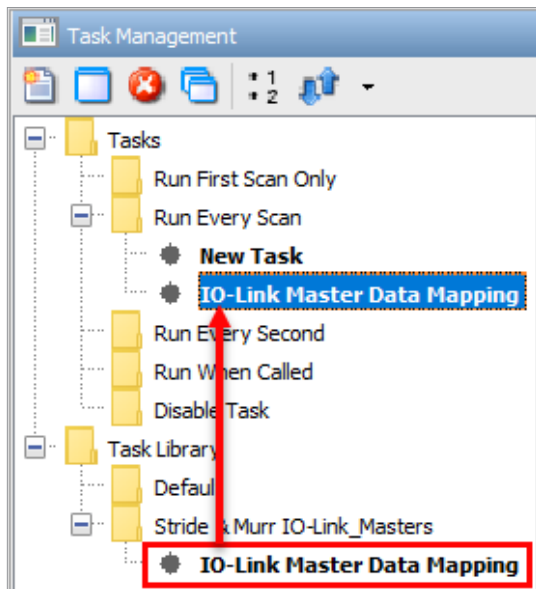



Fig. 7-16: Task Library – Drag and Drop Tasks.

6. Under the EtherNet/IP tab of the Hardware Config, double-click or drag the IO-Link Master EDS file to the device area underneath the hardware tabs (see section 7.2 for more details).
7. In the EtherNet/IP Client Properties do the following:
  - a. Select **Use Structure** and enter/select the **IO-Link Master.EIP\_Device** structure that was created as part of step 5.
  - b. For the **Device Name** type "IO-Link Master" – the name must be exact to work with the quick start code.
  - c. Enter the appropriate IP Address.
  - d. Click the  icon and select the **Exclusive Owner (32B) Message**.
  - e. In the **Extended Status** field enter/select the **IO-Link Master.EIP\_Device\_Extended\_Status** tag that was created as part of step 5.
  - f. In the **T->O** tab **Data Array** field enter/select the **IO-Link Master.Cyclic\_Input\_Data** tag that was created as part of step 5.
  - g. In the **O->T** tab **Data Array** field enter/select the **IO-Link Master.Cyclic\_Output\_Data** tag that was created as part of step 5.

**Pro EtherNet/IP Client Properties**

Use Structure IO-Link Master.EIP\_Dev ...

Device Name IO-Link Master

Ethernet Port CPU-ETH...

IP Address 192.168.1.20

TCP Port Number 44818

Close unused CIP Session after 30 secs

Swap Byte Order

From EDS: STRIDE IO-Link Basic DIO8 IOL8 (Revision 1.0)

Exclusive Owner (32B)(1) X

Enable Msg1Enable ...

Application Type  Exclusive Owner  
 Input Only / Listen Only

Enable Routing Slot Number 0

Connection Online Msg1ConnOnline ...

General Status Msg1GenStatus ...

Extended Status IO-Link Master.EIP\_Dev ...

Status Description Msg1StatusDesc ...

T->O (INPUT) O->T (OUTPUT) CONFIG DATA

Target To Originator (INPUT) Data

Include Run/Idle Header (When checked the message size will be increased by 4 bytes)

Delivery Option Multi... Run/Idle Status Msg1RunIdleStatus ...

RPI Time (msec) 250 (10 - 3000)

Assembly Instance/Connection Point 101 0x65 (101 - 101)

Specified Message Size Range (394, 394) Show EDS Parameters

Message Size from Array (bytes) 394

Datatype Integer, 8 Bit Unsigned, 1D Array

Data Array IO-Link Master.Cyclic\_Ir ... (394 elements)

Number of Elements 394

Monitor

OK Cancel Help

Fig. 7-17: EtherNet/IP Client Properties – IO-Link Master.

The screenshot shows the 'EtherNet/IP Client Properties' dialog box. The 'O->T (OUTPUT)' tab is selected, and the 'Originator To Target (OUTPUT) Data' section is expanded. The 'Data Array' field is highlighted with a red box, showing 'IO-Link Master.Cyclic\_O'. Other fields include 'RPI Time (msec)' set to 250, 'Assembly Instance/Connection Point' set to 111, and 'Number of Elements' set to 260. The 'Data Array' field is also labeled '(260 elements)'.

Fig. 7-18: EtherNet/IP Client Properties – IO-Link Master O->T Data Array.

8. Once all required field and tag entries have been made, per step 7, click **OK** and the EtherNet/IP Device will now appear in the hardware field. You are now ready to setup the quick start code for individual IO-Link field devices. Steps 9 thru 11 will walk you through the process to setup a Murr MVP IO-Link Hub.

- Follow steps 3 and 4 to import the “Murr MVP IO-Link Hub.adtkl” to the task library. Then drag the new **Murr MVP IO-Link Hub** task from the library to the **Run When Called** task folder. Click **OK** on the **Tag Conversion** pop-up.

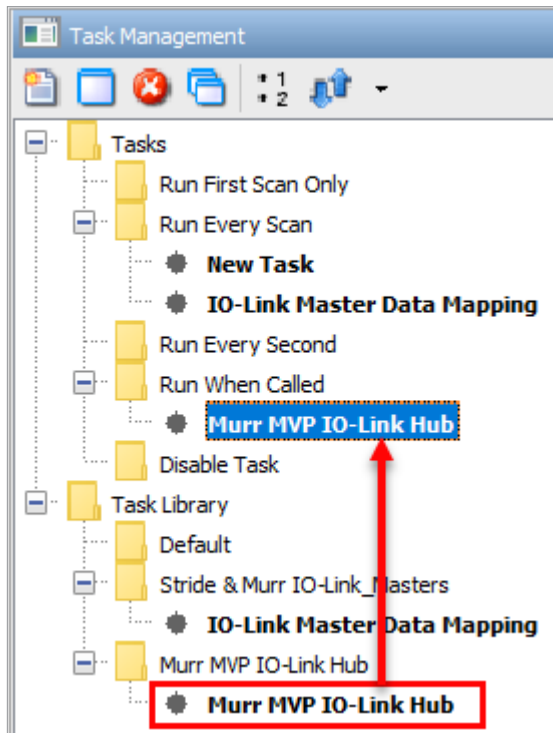

Fig. 7-20: Task Library – Drag and Drop IFM SA Series Task.

- In the Tag Database, create a ‘Murr IO Hubs’ tag that is a 1D array of the User Structure data type ‘Murr DIO Hub’. Then in the Run Every Scan task folder, create a new task (called **IO-Link Device Drivers** in this example) and add the **Copy Data**, **Call Task**, and **Copy Data** instructions as shown on rung 1 in Fig. 7-21. The IO-Link port number that the Murr MVP IO-Link Hub is connected to on the master module must correspond to the index number of the ‘IO-Link Master.Port’ tag in the second and third Copy Data instructions, as shown on rung 1 in Fig. 7-21 (IO-Link Master.Port(1) in this example). (In this example the device is connected to port 1 = X0 on the master module.)

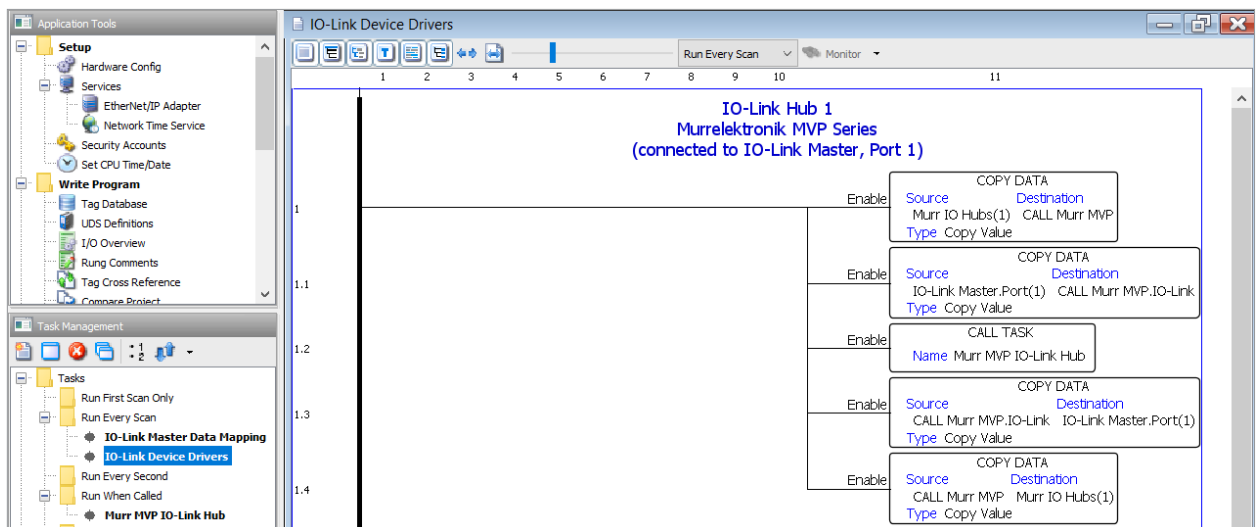

Fig. 7-21: IO-Link Device Drivers task – Murr MVP IO-Link Hub.

- Once all previous steps are complete, transfer the code to the CPU and, if the Murr MVP IO-Link Hub is connected, you should be receiving process data from the hub and be able to send control data to the hub. Check the **Murr IO Hubs(1)** tag values to see the live process data.

## 7.4. Commissioning without EDS



### NOTE

The byte addresses shown in the tables in Section 7.4 use 0-based addressing. The Productivity Suite software uses 1-based addressing. So, add 1 to any address in these tables when accessing these values in Productivity Suite.

### 7.4.1. Connections, parameters and properties



### NOTE

Listen Only connections can only be established if there is already an established Multicast exclusive owner connection.

### 7.4.2. Connection matrix

#### Exclusive Owner connection

Exclusive Owner Connection							
Configuration assembly		Description	Input assembly		Output assembly		
Instance	Length		Instance	Length	Instance	Length	
170	384	E01	Digital IOs, IOL 32 bytes with status and diagnostics	101	394	111	260

#### Input Only connection

Input Only Connection							
Configuration assembly		Description	Input assembly		Output assembly		
Instance	Length		Instance	Length	Instance	Length	
170	384	I01	Digital IOs, IOL 32 bytes with status and diagnostics	101	394	193	0

#### Listen Only connection

Listen Only Connection						
Connection Names		Description	Input assembly		Output assembly	
			Instance	Length	Instance	Length
L01		Digital IOs, IOL 32 bytes with status and diagnostics	101	394	192	0

### 7.4.3. Assemblies

#### Sequence of input bytes

Assembly Instance 101	
Instance	101
Total size in bytes	394
Digital input DI	0–1
DI Qualifier	2–5
System status	6–9
IO-Link port X0 input data	10–41
IO-Link port X0 input status	42–49
IO-Link port X1 input data	50–81
IO-Link port X1 input status	82–89
IO-Link port X2 input data	90–121
IO-Link port X2 input status	122–129

table continued on next page

<b>Assembly Instance 101 (continued)</b>	
<b>Instance</b>	<b>101</b>
<b>Total size in bytes</b>	<b>394</b>
IO-Link port X3 input data	130–161
IO-Link port X3 input status	162–169
IO-Link port X4 input data	170–201
IO-Link port X4 input status	202–209
IO-Link port X5 input data	210–241
IO-Link port X5 input status	242–249
IO-Link port X6 input data	250–281
IO-Link port X6 input status	282–289
IO-Link port X7 input data	290–321
IO-Link port X7 input status	322–329
Diagnostic buffer	330–393

### Sequence of output bytes

<b>Assembly Instance 111</b>	
<b>Instance</b>	<b>111</b>
<b>Total size in bytes</b>	<b>260</b>
Digital output	0–1
IO-Link port X0 output data	2–33
IO-Link port X1 output data	34–65
IO-Link port X2 output data	66–97
IO-Link port X3 output data	98–129
IO-Link port X4 output data	130–161
IO-Link port X5 output data	162–193
IO-Link port X6 output data	194–225
IO-Link port X7 output data	226–257
Diagnostic confirmation	258–259

### Sequence of configuration bytes

<b>Assembly Instance 170</b>	
<b>Instance</b>	<b>170</b>
<b>Total size in bytes</b>	<b>384</b>
General	0–1
Diagnostic	2–19
IO-Link port X0	20–43
IO-Link port X1	44–67
IO-Link port X2	68–91
IO-Link port X3	92–115
IO-Link port X4	116–139
IO-Link port X5	140–163
IO-Link port X6	164–187
IO-Link port X7	188–211
Reserved	212–379
WebUI	380
Reserved	381–383

#### 7.4.4. Configuration values

##### NOTICE

→ To avoid unexpected behavior of the fieldbus device, use only the values listed in this manual.

#### General parameters

General Parameters				
Byte	Parameters	Value	Default value	Description
0	Pin/Port Based IO Layout For Digital Channels	IO Layout: ■ 0 = Port Based ■ 1 = Pin Based	0	Parameterizes the layout of the I/O data
1	Reserved			

#### Diagnostic parameters

Diagnostic Parameters				
Byte	Parameters	Value	Default value	Description
2	Global Diagnostic Report	■ 0 = Disabled ■ 1 = Enabled	1	Global diagnostics report
3	Under Voltage Sensor Supply Diagnostic Message	■ 0 = Do Not Report ■ 1 = Report	1	Undervoltage US diagnostic report
4–5	Reserved	Fixed	17500	Do not modify value
6	Under Voltage Actuator Supply Diagnostic Message	■ 0 = Do Not Report ■ 1 = Report	1	Undervoltage UA diagnostic report
7–8	Reserved	Fixed	17500	Do not modify value
9	No Actuator Supply Diagnostic Message	■ 0 = Do Not Report ■ 1 = Report	1	Diagnostic report no UA
10	LED Indication For Suppressed Diagnostic Messages	■ 0 = No Led Indication ■ 1 = Led Indication	0	LED indication for suppressed diagnostic messages
11	Diagnostic Message Acknowledgement	■ 0 = Disabled ■ 1 = Enabled	0	Confirmation of diagnostic message
12	Port X0 Diagnostic Report	■ 0 = Report All Diagnostic Messages ■ 1 = Report All Diagnostic Messages Except for Wire Break ■ 2 = Report Only Wire Break Diagnostic Messages	0	Port X0 Diagnostic Report
13	Port X1 Diagnostic Report		0	Port X1 Diagnostic Report
14	Port X2 Diagnostic Report		0	Port X2 Diagnostic Report
15	Port X3 Diagnostic Report		0	Port X3 Diagnostic Report
16	Port X4 Diagnostic Report		0	Port X4 Diagnostic Report
17	Port X5 Diagnostic Report		0	Port X5 Diagnostic Report
18	Port X6 Diagnostic Report		0	Port X6 Diagnostic Report
19	Port X7 Diagnostic Report		0	Port X7 Diagnostic Report

## IO-Link port X0–X7 parameters

IO-Link Port X0 Parameters				
Byte	Parameters	Value	Default value	Description
20	IO-Link Function Pin 4	<ul style="list-style-type: none"> <li>■ 0 = Deactivated</li> <li>■ 1 = IO-Link Manual Configuration</li> <li>■ 2 = IO-Link Autostart</li> <li>■ 3 = Digital Input NO</li> <li>■ 4 = Digital Output</li> <li>■ 97 = Digital Input NC</li> </ul>	0	IO-Link function pin 4
21	Validation&Backup	<ul style="list-style-type: none"> <li>■ 0 = No Device Check</li> <li>■ 1 = Type Compatible Device V1.0</li> <li>■ 2 = Type Compatible Device V1.1</li> <li>■ 3 = Type Compatible Device V1.1, Backup&amp;Restore</li> <li>■ 4 = Type Compatible Device V1.1, Restore</li> </ul>	0	Validation and backup * see footnote
22	Behavior Pin 2 (Ch1Y)	<ul style="list-style-type: none"> <li>■ 0 = Automatic Mode (DIO)</li> <li>■ 1 = Digital Input</li> <li>■ 2 = Digital Output</li> <li>■ 5 = AUX Power</li> <li>■ 6 = Digital Input NC</li> <li>■ 7 = Deactivated</li> </ul>	0	Behavior Pin 2 (Ch1Y)
23	PortCycleTime	<ul style="list-style-type: none"> <li>■ 0: As fast as possible</li> <li>■ 1–255: Bit0–5 Multiplier / Bit6–7 TimeBase[ms]</li> </ul>	0	Port cycle time
24–25	Vendor ID	<ul style="list-style-type: none"> <li>■ Vendor ID of the attached IO-Link device for the use with validation setting</li> </ul>	0	
26–29	Device ID	<ul style="list-style-type: none"> <li>■ Device ID of the attached IO-Link device for the use with validation setting</li> </ul>	0	
30	IO-Link Process Data Swap	<ul style="list-style-type: none"> <li>■ 0 = No Swap</li> <li>■ 1 = 16 Bit Swap</li> <li>■ 2 = 32 Bit Swap</li> <li>■ 3 = Full Swap</li> </ul>	0	IO-Link process data exchange
31	IO-Link Event Integration	<ul style="list-style-type: none"> <li>■ 0 = Standard Integration</li> <li>■ 1 = Murrelektronik Integration</li> <li>■ 2 = Murrelektronik IO-Link Extended Integration</li> </ul>	0	IO-Link event integration
32	Digital Input Signal Filter Pin 4	<ul style="list-style-type: none"> <li>■ 0 = No Filter</li> <li>■ 1 = 1 ms</li> <li>■ 2 = 3 ms</li> <li>■ 3 = 5 ms</li> <li>■ 4 = 10 ms</li> <li>■ 5 = 15 ms</li> </ul>	0	Digital input signal filter pin 4
33	Digital Input Signal Filter Pin 2		0	Digital input signal filter pin 2
34–35	Reserved	Fixed	0	Do not modify value
36	Digital Port Function Configuration Pin 1	<ul style="list-style-type: none"> <li>■ 0 = Deactivated</li> <li>■ 1 = L+ (US) Sensor Supply</li> </ul>	1	Digital port function configuration pin 1
37–39	Reserved	Fixed	1	Do not modify value
40	Output Fault Recovery Mode Pin 2	<ul style="list-style-type: none"> <li>■ 0 = Automatic Recovery</li> <li>■ 1 = Manual Recovery</li> </ul>	0	Output fault recovery mode pin 2
41	Output Fault Recovery Mode Pin 4		0	Output fault recovery mode pin 4
42	IO-Link Input Length	<ul style="list-style-type: none"> <li>■ 0–32 bytes</li> </ul>	0	IO-Link input length
43	IO-Link Output Length	<ul style="list-style-type: none"> <li>■ 0–32 bytes</li> </ul>	0	IO-Link output length

\* When switching to the "Restore" state, any device configurations previously stored in the device are discarded, especially when switching from "Backup&Restore" to "Restore".  
If a compatible device is connected for the first time in the "Restore" state, the master fetches the data storage data (one-time backup) from the device, saves it and then sends this data to each newly connected, compatible device with a different configuration (restore).

**NOTE**

Data storage can only be implemented using the EDS file. Byte 20 "IO-Link Function Pin 4" must be configured as "IO-Link Manual Configuration" for data storage settings to work correctly. See notes in Section [3.2.1](#) for more details on data storage implementation.

IO-Link Port X1 Parameters				
Byte	Parameters	Value	Default value	Description
44	IO-Link Function Pin 4	<ul style="list-style-type: none"> <li>■ 0 = Deactivated</li> <li>■ 1 = IO-Link Manual Configuration</li> <li>■ 2 = IO-Link Autostart</li> <li>■ 3 = Digital Input NO</li> <li>■ 4 = Digital Output</li> <li>■ 97 = Digital Input NC</li> </ul>	0	IO-Link function pin 4
45	Validation&Backup	<ul style="list-style-type: none"> <li>■ 0 = No Device Check</li> <li>■ 1 = Type Compatible Device V1.0</li> <li>■ 2 = Type Compatible Device V1.1</li> <li>■ 3 = Type Compatible Device V1.1, Backup&amp;Restore</li> <li>■ 4 = Type Compatible Device V1.1, Restore</li> </ul>	0	Validation and backup * see footnote
46	Behavior Pin 2 (Ch1Y)	<ul style="list-style-type: none"> <li>■ 0 = Automatic Mode (DIO)</li> <li>■ 1 = Digital Input</li> <li>■ 2 = Digital Output</li> <li>■ 5 = AUX Power</li> <li>■ 6 = Digital Input NC</li> <li>■ 7 = Deactivated</li> </ul>	0	Behavior Pin 2 (Ch1Y)
47	PortCycleTime	<ul style="list-style-type: none"> <li>■ 0: As fast as possible</li> <li>■ 1–255: Bit0–5 Multiplier / Bit6–7 TimeBase[ms]</li> </ul>	0	Port cycle time
48–49	Vendor ID	<ul style="list-style-type: none"> <li>■ Vendor ID of the attached IO-Link device for the use with validation setting</li> </ul>	0	
50–53	Device ID	<ul style="list-style-type: none"> <li>■ Device ID of the attached IO-Link device for the use with validation setting</li> </ul>	0	
54	IO-Link Process Data Swap	<ul style="list-style-type: none"> <li>■ 0 = No Swap</li> <li>■ 1 = 16 Bit Swap</li> <li>■ 2 = 32 Bit Swap</li> <li>■ 3 = Full Swap</li> </ul>	0	IO-Link process data exchange
55	IO-Link Event Integration	<ul style="list-style-type: none"> <li>■ 0 = Standard Integration</li> <li>■ 1 = Murrelektronik Integration</li> <li>■ 2 = Murrelektronik IO-Link Extended Integration</li> </ul>	0	IO-Link event integration
56	Digital Input Signal Filter Pin 4	<ul style="list-style-type: none"> <li>■ 0 = No Filter</li> <li>■ 1 = 1 ms</li> <li>■ 2 = 3 ms</li> <li>■ 3 = 5 ms</li> <li>■ 4 = 10 ms</li> <li>■ 5 = 15 ms</li> </ul>	0	Digital input signal filter pin 4
57	Digital Input Signal Filter Pin 2		0	Digital input signal filter pin 2
58–59	Reserved	Fixed	0	Do not modify value
60	Digital Port Function Configuration Pin 1	<ul style="list-style-type: none"> <li>■ 0 = Deactivated</li> <li>■ 1 = L+ (US) Sensor Supply</li> </ul>	1	Digital port function configuration pin 1
61–63	Reserved	Fixed	1	Do not modify value
64	Output Fault Recovery Mode Pin 2	<ul style="list-style-type: none"> <li>■ 0 = Automatic Recovery</li> <li>■ 1 = Manual Recovery</li> </ul>	0	Output fault recovery mode pin 2
65	Output Fault Recovery Mode Pin 4		0	Output fault recovery mode pin 4
66	IO-Link Input Length	<ul style="list-style-type: none"> <li>■ 0–32 bytes</li> </ul>	0	IO-Link input length
67	IO-Link Output Length	<ul style="list-style-type: none"> <li>■ 0–32 bytes</li> </ul>	0	IO-Link output length

\* When switching to the “Restore” state, any device configurations previously stored in the device are discarded, especially when switching from “Backup&Restore” to “Restore”.  
If a compatible device is connected for the first time in the “Restore” state, the master fetches the data storage data (one-time backup) from the device, saves it and then sends this data to each newly connected, compatible device with a different configuration (restore).

**NOTE**

Data storage can only be implemented using the EDS file. Byte 44 “IO-Link Function Pin 4” must be configured as “IO-Link Manual Configuration” for data storage settings to work correctly. See notes in Section 3.2.1 for more details on data storage implementation.

IO-Link Port X2 Parameters				
Byte	Parameters	Value	Default value	Description
68	IO-Link Function Pin 4	<ul style="list-style-type: none"> <li>■ 0 = Deactivated</li> <li>■ 1 = IO-Link Manual Configuration</li> <li>■ 2 = IO-Link Autostart</li> <li>■ 3 = Digital Input NO</li> <li>■ 4 = Digital Output</li> <li>■ 97 = Digital Input NC</li> </ul>	0	IO-Link function pin 4
69	Validation&Backup	<ul style="list-style-type: none"> <li>■ 0 = No Device Check</li> <li>■ 1 = Type Compatible Device V1.0</li> <li>■ 2 = Type Compatible Device V1.1</li> <li>■ 3 = Type Compatible Device V1.1, Backup&amp;Restore</li> <li>■ 4 = Type Compatible Device V1.1, Restore</li> </ul>	0	Validation and backup * see footnote
70	Behavior Pin 2 (Ch1Y)	<ul style="list-style-type: none"> <li>■ 0 = Automatic Mode (DIO)</li> <li>■ 1 = Digital Input</li> <li>■ 2 = Digital Output</li> <li>■ 5 = AUX Power</li> <li>■ 6 = Digital Input NC</li> <li>■ 7 = Deactivated</li> </ul>	0	Behavior Pin 2 (Ch1Y)
71	PortCycleTime	<ul style="list-style-type: none"> <li>■ 0: As fast as possible</li> <li>■ 1–255: Bit0–5 Multiplier / Bit6–7 TimeBase[ms]</li> </ul>	0	Port cycle time
72–73	Vendor ID	<ul style="list-style-type: none"> <li>■ Vendor ID of the attached IO-Link device for the use with validation setting</li> </ul>	0	
74–77	Device ID	<ul style="list-style-type: none"> <li>■ Device ID of the attached IO-Link device for the use with validation setting</li> </ul>	0	
78	IO-Link Process Data Swap	<ul style="list-style-type: none"> <li>■ 0 = No Swap</li> <li>■ 1 = 16 Bit Swap</li> <li>■ 2 = 32 Bit Swap</li> <li>■ 3 = Full Swap</li> </ul>	0	IO-Link process data exchange
79	IO-Link Event Integration	<ul style="list-style-type: none"> <li>■ 0 = Standard Integration</li> <li>■ 1 = Murrelektronik Integration</li> <li>■ 2 = Murrelektronik IO-Link Extended Integration</li> </ul>	0	IO-Link event integration
80	Digital Input Signal Filter Pin 4	<ul style="list-style-type: none"> <li>■ 0 = No Filter</li> <li>■ 1 = 1 ms</li> <li>■ 2 = 3 ms</li> <li>■ 3 = 5 ms</li> <li>■ 4 = 10 ms</li> <li>■ 5 = 15 ms</li> </ul>	0	Digital input signal filter pin 4
81	Digital Input Signal Filter Pin 2		0	Digital input signal filter pin 2
82–83	Reserved	Fixed	0	Do not modify value
84	Digital Port Function Configuration Pin 1	<ul style="list-style-type: none"> <li>■ 0 = Deactivated</li> <li>■ 1 = L+ (US) Sensor Supply</li> </ul>	1	Digital port function configuration pin 1
85–87	Reserved	Fixed	1	Do not modify value
88	Output Fault Recovery Mode Pin 2	<ul style="list-style-type: none"> <li>■ 0 = Automatic Recovery</li> <li>■ 1 = Manual Recovery</li> </ul>	0	Output fault recovery mode pin 2
89	Output Fault Recovery Mode Pin 4		0	Output fault recovery mode pin 4
90	IO-Link Input Length	<ul style="list-style-type: none"> <li>■ 0–32 bytes</li> </ul>	0	IO-Link input length
91	IO-Link Output Length	<ul style="list-style-type: none"> <li>■ 0–32 bytes</li> </ul>	0	IO-Link output length

\* When switching to the “Restore” state, any device configurations previously stored in the device are discarded, especially when switching from “Backup&Restore” to “Restore”.  
If a compatible device is connected for the first time in the “Restore” state, the master fetches the data storage data (one-time backup) from the device, saves it and then sends this data to each newly connected, compatible device with a different configuration (restore).

**NOTE**

Data storage can only be implemented using the EDS file. Byte 68 “IO-Link Function Pin 4” must be configured as “IO-Link Manual Configuration” for data storage settings to work correctly. See notes in Section [3.2.1](#) for more details on data storage implementation.

IO-Link Port X3 Parameters				
Byte	Parameters	Value	Default value	Description
92	IO-Link Function Pin 4	<ul style="list-style-type: none"> <li>■ 0 = Deactivated</li> <li>■ 1 = IO-Link Manual Configuration</li> <li>■ 2 = IO-Link Autostart</li> <li>■ 3 = Digital Input NO</li> <li>■ 4 = Digital Output</li> <li>■ 97 = Digital Input NC</li> </ul>	0	IO-Link function pin 4
93	Validation&Backup	<ul style="list-style-type: none"> <li>■ 0 = No Device Check</li> <li>■ 1 = Type Compatible Device V1.0</li> <li>■ 2 = Type Compatible Device V1.1</li> <li>■ 3 = Type Compatible Device V1.1, Backup&amp;Restore</li> <li>■ 4 = Type Compatible Device V1.1, Restore</li> </ul>	0	Validation and backup * see footnote
94	Behavior Pin 2 (Ch1Y)	<ul style="list-style-type: none"> <li>■ 0 = Automatic Mode (DIO)</li> <li>■ 1 = Digital Input</li> <li>■ 2 = Digital Output</li> <li>■ 5 = AUX Power</li> <li>■ 6 = Digital Input NC</li> <li>■ 7 = Deactivated</li> </ul>	0	Behavior Pin 2 (Ch1Y)
95	PortCycleTime	<ul style="list-style-type: none"> <li>■ 0: As fast as possible</li> <li>■ 1–255: Bit0–5 Multiplier / Bit6–7 TimeBase[ms]</li> </ul>	0	Port cycle time
96–97	Vendor ID	<ul style="list-style-type: none"> <li>■ Vendor ID of the attached IO-Link device for the use with validation setting</li> </ul>	0	
98–101	Device ID	<ul style="list-style-type: none"> <li>■ Device ID of the attached IO-Link device for the use with validation setting</li> </ul>	0	
102	IO-Link Process Data Swap	<ul style="list-style-type: none"> <li>■ 0 = No Swap</li> <li>■ 1 = 16 Bit Swap</li> <li>■ 2 = 32 Bit Swap</li> <li>■ 3 = Full Swap</li> </ul>	0	IO-Link process data exchange
103	IO-Link Event Integration	<ul style="list-style-type: none"> <li>■ 0 = Standard Integration</li> <li>■ 1 = Murrelektronik Integration</li> <li>■ 2 = Murrelektronik IO-Link Extended Integration</li> </ul>	0	IO-Link event integration
104	Digital Input Signal Filter Pin 4	<ul style="list-style-type: none"> <li>■ 0 = No Filter</li> <li>■ 1 = 1 ms</li> <li>■ 2 = 3 ms</li> <li>■ 3 = 5 ms</li> <li>■ 4 = 10 ms</li> <li>■ 5 = 15 ms</li> </ul>	0	Digital input signal filter pin 4
105	Digital Input Signal Filter Pin 2		0	Digital input signal filter pin 2
106–107	Reserved	Fixed	0	Do not modify value
108	Digital Port Function Configuration Pin 1	<ul style="list-style-type: none"> <li>■ 0 = Deactivated</li> <li>■ 1 = L+ (US) Sensor Supply</li> </ul>	1	Digital port function configuration pin 1
109–111	Reserved	Fixed	1	Do not modify value
112	Output Fault Recovery Mode Pin 2	<ul style="list-style-type: none"> <li>■ 0 = Automatic Recovery</li> <li>■ 1 = Manual Recovery</li> </ul>	0	Output fault recovery mode pin 2
113	Output Fault Recovery Mode Pin 4		0	Output fault recovery mode pin 4
114	IO-Link Input Length	<ul style="list-style-type: none"> <li>■ 0–32 bytes</li> </ul>	0	IO-Link input length
115	IO-Link Output Length	<ul style="list-style-type: none"> <li>■ 0–32 bytes</li> </ul>	0	IO-Link output length

\* When switching to the “Restore” state, any device configurations previously stored in the device are discarded, especially when switching from “Backup&Restore” to “Restore”.  
If a compatible device is connected for the first time in the “Restore” state, the master fetches the data storage data (one-time backup) from the device, saves it and then sends this data to each newly connected, compatible device with a different configuration (restore).

**NOTE**

Data storage can only be implemented using the EDS file. Byte 92 “IO-Link Function Pin 4” must be configured as “IO-Link Manual Configuration” for data storage settings to work correctly. See notes in Section [3.2.1](#) for more details on data storage implementation.

IO-Link Port X4 Parameters				
Byte	Parameters	Value	Default value	Description
116	IO-Link Function Pin 4	<ul style="list-style-type: none"> <li>■ 0 = Deactivated</li> <li>■ 1 = IO-Link Manual Configuration</li> <li>■ 2 = IO-Link Autostart</li> <li>■ 3 = Digital Input NO</li> <li>■ 4 = Digital Output</li> <li>■ 97 = Digital Input NC</li> </ul>	0	IO-Link function pin 4
117	Validation&Backup	<ul style="list-style-type: none"> <li>■ 0 = No Device Check</li> <li>■ 1 = Type Compatible Device V1.0</li> <li>■ 2 = Type Compatible Device V1.1</li> <li>■ 3 = Type Compatible Device V1.1, Backup&amp;Restore</li> <li>■ 4 = Type Compatible Device V1.1, Restore</li> </ul>	0	Validation and backup * see footnote
118	Behavior Pin 2 (Ch1Y)	<ul style="list-style-type: none"> <li>■ 0 = Automatic Mode (DIO)</li> <li>■ 1 = Digital Input</li> <li>■ 2 = Digital Output</li> <li>■ 5 = AUX Power</li> <li>■ 6 = Digital Input NC</li> <li>■ 7 = Deactivated</li> </ul>	0	Behavior Pin 2 (Ch1Y)
119	PortCycleTime	<ul style="list-style-type: none"> <li>■ 0: As fast as possible</li> <li>■ 1–255: Bit0–5 Multiplier / Bit6–7 TimeBase[ms]</li> </ul>	0	Port cycle time
120-121	Vendor ID	<ul style="list-style-type: none"> <li>■ Vendor ID of the attached IO-Link device for the use with validation setting</li> </ul>	0	
122-125	Device ID	<ul style="list-style-type: none"> <li>■ Device ID of the attached IO-Link device for the use with validation setting</li> </ul>	0	
126	IO-Link Process Data Swap	<ul style="list-style-type: none"> <li>■ 0 = No Swap</li> <li>■ 1 = 16 Bit Swap</li> <li>■ 2 = 32 Bit Swap</li> <li>■ 3 = Full Swap</li> </ul>	0	IO-Link process data exchange
127	IO-Link Event Integration	<ul style="list-style-type: none"> <li>■ 0 = Standard Integration</li> <li>■ 1 = Murrelektronik Integration</li> <li>■ 2 = Murrelektronik IO-Link Extended Integration</li> </ul>	0	IO-Link event integration
128	Digital Input Signal Filter Pin 4	<ul style="list-style-type: none"> <li>■ 0 = No Filter</li> <li>■ 1 = 1 ms</li> <li>■ 2 = 3 ms</li> <li>■ 3 = 5 ms</li> <li>■ 4 = 10 ms</li> <li>■ 5 = 15 ms</li> </ul>	0	Digital input signal filter pin 4
129	Digital Input Signal Filter Pin 2		0	Digital input signal filter pin 2
130-131	Reserved	Fixed	0	Do not modify value
132	Digital Port Function Configuration Pin 1	<ul style="list-style-type: none"> <li>■ 0 = Deactivated</li> <li>■ 1 = L+ (US) Sensor Supply</li> </ul>	1	Digital port function configuration pin 1
133-135	Reserved	Fixed	1	Do not modify value
136	Output Fault Recovery Mode Pin 2	<ul style="list-style-type: none"> <li>■ 0 = Automatic Recovery</li> <li>■ 1 = Manual Recovery</li> </ul>	0	Output fault recovery mode pin 2
137	Output Fault Recovery Mode Pin 4		0	Output fault recovery mode pin 4
138	IO-Link Input Length	<ul style="list-style-type: none"> <li>■ 0–32 bytes</li> </ul>	0	IO-Link input length
139	IO-Link Output Length	<ul style="list-style-type: none"> <li>■ 0–32 bytes</li> </ul>	0	IO-Link output length

\* When switching to the “Restore” state, any device configurations previously stored in the device are discarded, especially when switching from “Backup&Restore” to “Restore”.  
If a compatible device is connected for the first time in the “Restore” state, the master fetches the data storage data (one-time backup) from the device, saves it and then sends this data to each newly connected, compatible device with a different configuration (restore).

**NOTE**

Data storage can only be implemented using the EDS file. Byte 116 “IO-Link Function Pin 4” must be configured as “IO-Link Manual Configuration” for data storage settings to work correctly. See notes in Section 3.2.1 for more details on data storage implementation.

IO-Link Port X5 Parameters				
Byte	Parameters	Value	Default value	Description
140	IO-Link Function Pin 4	<ul style="list-style-type: none"> <li>■ 0 = Deactivated</li> <li>■ 1 = IO-Link Manual Configuration</li> <li>■ 2 = IO-Link Autostart</li> <li>■ 3 = Digital Input NO</li> <li>■ 4 = Digital Output</li> <li>■ 97 = Digital Input NC</li> </ul>	0	IO-Link function pin 4
141	Validation&Backup	<ul style="list-style-type: none"> <li>■ 0 = No Device Check</li> <li>■ 1 = Type Compatible Device V1.0</li> <li>■ 2 = Type Compatible Device V1.1</li> <li>■ 3 = Type Compatible Device V1.1, Backup&amp;Restore</li> <li>■ 4 = Type Compatible Device V1.1, Restore</li> </ul>	0	Validation and backup * see footnote
142	Behavior Pin 2 (Ch1Y)	<ul style="list-style-type: none"> <li>■ 0 = Automatic Mode (DIO)</li> <li>■ 1 = Digital Input</li> <li>■ 2 = Digital Output</li> <li>■ 5 = AUX Power</li> <li>■ 6 = Digital Input NC</li> <li>■ 7 = Deactivated</li> </ul>	0	Behavior Pin 2 (Ch1Y)
143	PortCycleTime	<ul style="list-style-type: none"> <li>■ 0: As fast as possible</li> <li>■ 1–255: Bit0–5 Multiplier / Bit6–7 TimeBase[ms]</li> </ul>	0	Port cycle time
144-145	Vendor ID	<ul style="list-style-type: none"> <li>■ Vendor ID of the attached IO-Link device for the use with validation setting</li> </ul>	0	
146-149	Device ID	<ul style="list-style-type: none"> <li>■ Device ID of the attached IO-Link device for the use with validation setting</li> </ul>	0	
150	IO-Link Process Data Swap	<ul style="list-style-type: none"> <li>■ 0 = No Swap</li> <li>■ 1 = 16 Bit Swap</li> <li>■ 2 = 32 Bit Swap</li> <li>■ 3 = Full Swap</li> </ul>	0	IO-Link process data exchange
151	IO-Link Event Integration	<ul style="list-style-type: none"> <li>■ 0 = Standard Integration</li> <li>■ 1 = Murrelektronik Integration</li> <li>■ 2 = Murrelektronik IO-Link Extended Integration</li> </ul>	0	IO-Link event integration
152	Digital Input Signal Filter Pin 4	<ul style="list-style-type: none"> <li>■ 0 = No Filter</li> <li>■ 1 = 1 ms</li> <li>■ 2 = 3 ms</li> <li>■ 3 = 5 ms</li> <li>■ 4 = 10 ms</li> <li>■ 5 = 15 ms</li> </ul>	0	Digital input signal filter pin 4
153	Digital Input Signal Filter Pin 2		0	Digital input signal filter pin 2
154-155	Reserved	Fixed	0	Do not modify value
156	Digital Port Function Configuration Pin 1	<ul style="list-style-type: none"> <li>■ 0 = Deactivated</li> <li>■ 1 = L+ (US) Sensor Supply</li> </ul>	1	Digital port function configuration pin 1
157-159	Reserved	Fixed	1	Do not modify value
160	Output Fault Recovery Mode Pin 2	<ul style="list-style-type: none"> <li>■ 0 = Automatic Recovery</li> <li>■ 1 = Manual Recovery</li> </ul>	0	Output fault recovery mode pin 2
161	Output Fault Recovery Mode Pin 4		0	Output fault recovery mode pin 4
162	IO-Link Input Length	<ul style="list-style-type: none"> <li>■ 0–32 bytes</li> </ul>	0	IO-Link input length
163	IO-Link Output Length	<ul style="list-style-type: none"> <li>■ 0–32 bytes</li> </ul>	0	IO-Link output length

\* When switching to the “Restore” state, any device configurations previously stored in the device are discarded, especially when switching from “Backup&Restore” to “Restore”.  
If a compatible device is connected for the first time in the “Restore” state, the master fetches the data storage data (one-time backup) from the device, saves it and then sends this data to each newly connected, compatible device with a different configuration (restore).

**NOTE**

Data storage can only be implemented using the EDS file. Byte 140 “IO-Link Function Pin 4” must be configured as “IO-Link Manual Configuration” for data storage settings to work correctly. See notes in Section 3.2.1 for more details on data storage implementation.

IO-Link Port X6 Parameters				
Byte	Parameters	Value	Default value	Description
164	IO-Link Function Pin 4	<ul style="list-style-type: none"> <li>■ 0 = Deactivated</li> <li>■ 1 = IO-Link Manual Configuration</li> <li>■ 2 = IO-Link Autostart</li> <li>■ 3 = Digital Input NO</li> <li>■ 4 = Digital Output</li> <li>■ 97 = Digital Input NC</li> </ul>	0	IO-Link function pin 4
165	Validation&Backup	<ul style="list-style-type: none"> <li>■ 0 = No Device Check</li> <li>■ 1 = Type Compatible Device V1.0</li> <li>■ 2 = Type Compatible Device V1.1</li> <li>■ 3 = Type Compatible Device V1.1, Backup&amp;Restore</li> <li>■ 4 = Type Compatible Device V1.1, Restore</li> </ul>	0	Validation and backup * see footnote
166	Behavior Pin 2 (Ch1Y)	<ul style="list-style-type: none"> <li>■ 0 = Automatic Mode (DIO)</li> <li>■ 1 = Digital Input</li> <li>■ 2 = Digital Output</li> <li>■ 5 = AUX Power</li> <li>■ 6 = Digital Input NC</li> <li>■ 7 = Deactivated</li> </ul>	0	Behavior Pin 2 (Ch1Y)
167	PortCycleTime	<ul style="list-style-type: none"> <li>■ 0: As fast as possible</li> <li>■ 1–255: Bit0–5 Multiplier / Bit6–7 TimeBase[ms]</li> </ul>	0	Port cycle time
168-169	Vendor ID	<ul style="list-style-type: none"> <li>■ Vendor ID of the attached IO-Link device for the use with validation setting</li> </ul>	0	
170-173	Device ID	<ul style="list-style-type: none"> <li>■ Device ID of the attached IO-Link device for the use with validation setting</li> </ul>	0	
174	IO-Link Process Data Swap	<ul style="list-style-type: none"> <li>■ 0 = No Swap</li> <li>■ 1 = 16 Bit Swap</li> <li>■ 2 = 32 Bit Swap</li> <li>■ 3 = Full Swap</li> </ul>	0	IO-Link process data exchange
175	IO-Link Event Integration	<ul style="list-style-type: none"> <li>■ 0 = Standard Integration</li> <li>■ 1 = Murrelektronik Integration</li> <li>■ 2 = Murrelektronik IO-Link Extended Integration</li> </ul>	0	IO-Link event integration
176	Digital Input Signal Filter Pin 4	<ul style="list-style-type: none"> <li>■ 0 = No Filter</li> <li>■ 1 = 1 ms</li> <li>■ 2 = 3 ms</li> <li>■ 3 = 5 ms</li> <li>■ 4 = 10 ms</li> <li>■ 5 = 15 ms</li> </ul>	0	Digital input signal filter pin 4
177	Digital Input Signal Filter Pin 2		0	Digital input signal filter pin 2
178-179	Reserved	Fixed	0	Do not modify value
180	Digital Port Function Configuration Pin 1	<ul style="list-style-type: none"> <li>■ 0 = Deactivated</li> <li>■ 1 = L+ (US) Sensor Supply</li> </ul>	1	Digital port function configuration pin 1
181-183	Reserved	Fixed	1	Do not modify value
184	Output Fault Recovery Mode Pin 2	<ul style="list-style-type: none"> <li>■ 0 = Automatic Recovery</li> <li>■ 1 = Manual Recovery</li> </ul>	0	Output fault recovery mode pin 2
185	Output Fault Recovery Mode Pin 4		0	Output fault recovery mode pin 4
186	IO-Link Input Length	<ul style="list-style-type: none"> <li>■ 0–32 bytes</li> </ul>	0	IO-Link input length
187	IO-Link Output Length	<ul style="list-style-type: none"> <li>■ 0–32 bytes</li> </ul>	0	IO-Link output length

\* When switching to the “Restore” state, any device configurations previously stored in the device are discarded, especially when switching from “Backup&Restore” to “Restore”.  
If a compatible device is connected for the first time in the “Restore” state, the master fetches the data storage data (one-time backup) from the device, saves it and then sends this data to each newly connected, compatible device with a different configuration (restore).

**NOTE**

Data storage can only be implemented using the EDS file. Byte 164 “IO-Link Function Pin 4” must be configured as “IO-Link Manual Configuration” for data storage settings to work correctly. See notes in Section 3.2.1 for more details on data storage implementation.

IO-Link Port X7 Parameters				
Byte	Parameters	Value	Default value	Description
188	IO-Link Function Pin 4	<ul style="list-style-type: none"> <li>■ 0 = Deactivated</li> <li>■ 1 = IO-Link Manual Configuration</li> <li>■ 2 = IO-Link Autostart</li> <li>■ 3 = Digital Input NO</li> <li>■ 4 = Digital Output</li> <li>■ 97 = Digital Input NC</li> </ul>	0	IO-Link function pin 4
189	Validation&Backup	<ul style="list-style-type: none"> <li>■ 0 = No Device Check</li> <li>■ 1 = Type Compatible Device V1.0</li> <li>■ 2 = Type Compatible Device V1.1</li> <li>■ 3 = Type Compatible Device V1.1, Backup&amp;Restore</li> <li>■ 4 = Type Compatible Device V1.1, Restore</li> </ul>	0	Validation and backup * see footnote
190	Behavior Pin 2 (Ch1Y)	<ul style="list-style-type: none"> <li>■ 0 = Automatic Mode (DIO)</li> <li>■ 1 = Digital Input</li> <li>■ 2 = Digital Output</li> <li>■ 5 = AUX Power</li> <li>■ 6 = Digital Input NC</li> <li>■ 7 = Deactivated</li> </ul>	0	Behavior Pin 2 (Ch1Y)
191	PortCycleTime	<ul style="list-style-type: none"> <li>■ 0: As fast as possible</li> <li>■ 1–255: Bit0–5 Multiplier / Bit6–7 TimeBase[ms]</li> </ul>	0	Port cycle time
192-193	Vendor ID	<ul style="list-style-type: none"> <li>■ Vendor ID of the attached IO-Link device for the use with validation setting</li> </ul>	0	
194-197	Device ID	<ul style="list-style-type: none"> <li>■ Device ID of the attached IO-Link device for the use with validation setting</li> </ul>	0	
198	IO-Link Process Data Swap	<ul style="list-style-type: none"> <li>■ 0 = No Swap</li> <li>■ 1 = 16 Bit Swap</li> <li>■ 2 = 32 Bit Swap</li> <li>■ 3 = Full Swap</li> </ul>	0	IO-Link process data exchange
199	IO-Link Event Integration	<ul style="list-style-type: none"> <li>■ 0 = Standard Integration</li> <li>■ 1 = Murrelektronik Integration</li> <li>■ 2 = Murrelektronik IO-Link Extended Integration</li> </ul>	0	IO-Link event integration
200	Digital Input Signal Filter Pin 4	<ul style="list-style-type: none"> <li>■ 0 = No Filter</li> <li>■ 1 = 1 ms</li> <li>■ 2 = 3 ms</li> <li>■ 3 = 5 ms</li> <li>■ 4 = 10 ms</li> <li>■ 5 = 15 ms</li> </ul>	0	Digital input signal filter pin 4
201	Digital Input Signal Filter Pin 2		0	Digital input signal filter pin 2
202-203	Reserved	Fixed	0	Do not modify value
204	Digital Port Function Configuration Pin 1	<ul style="list-style-type: none"> <li>■ 0 = Deactivated</li> <li>■ 1 = L+ (US) Sensor Supply</li> </ul>	1	Digital port function configuration pin 1
205-207	Reserved	Fixed	1	Do not modify value
208	Output Fault Recovery Mode Pin 2	<ul style="list-style-type: none"> <li>■ 0 = Automatic Recovery</li> <li>■ 1 = Manual Recovery</li> </ul>	0	Output fault recovery mode pin 2
209	Output Fault Recovery Mode Pin 4		0	Output fault recovery mode pin 4
210	IO-Link Input Length	<ul style="list-style-type: none"> <li>■ 0–32 bytes</li> </ul>	0	IO-Link input length
211	IO-Link Output Length	<ul style="list-style-type: none"> <li>■ 0–32 bytes</li> </ul>	0	IO-Link output length

\* When switching to the “Restore” state, any device configurations previously stored in the device are discarded, especially when switching from “Backup&Restore” to “Restore”.  
If a compatible device is connected for the first time in the “Restore” state, the master fetches the data storage data (one-time backup) from the device, saves it and then sends this data to each newly connected, compatible device with a different configuration (restore).

**NOTE**

Data storage can only be implemented using the EDS file. Byte 188 “IO-Link Function Pin 4” must be configured as “IO-Link Manual Configuration” for data storage settings to work correctly. See notes in Section 3.2.1 for more details on data storage implementation.

**Required Fixed Data**

Required Fixed Data				
Byte	Parameters	Value	Default value	Description
213–214	Reserved	Fixed	4840	Do not modify value
223	Reserved	Fixed	23	Do not modify value
248	Reserved	Fixed	64	Do not modify value
314	Reserved	Fixed	64	Do not modify value

**WebUI parameters**

WebUI Parameters				
Byte	Parameters	Value	Default value	Description
380	Use Of WebUI	<ul style="list-style-type: none"> <li>■ 0 = Disabled</li> <li>■ 1 = Enabled</li> </ul>	1	Activates or disables the WebUI
381-383	Reserved		0	Reserved for future use

## 8. Configuration and parameterization



### ⚠ WARNING!

Protection function may be impaired if the module configuration is changed.

The person who makes the changes is responsible for maintaining the protective function of the device.

- Make sure that only authorized persons change the configuration.
- If you change the configuration, use the password hierarchy provided by your engineering software.
- After every change to the configuration, test the protection equipment for efficiency.

### 8.1. Module configuration

#### Overview

There are two options for configuring the devices:

- Download an EDS file from the AutomationDirect.com website or the place of purchase. Then, import the EDS files into your programming software (see [Section 7.1, “Loading the EDS files”](#) for an example of how to do this).  
Using the EDS file allows you to benefit from the advantages of a preconfigured connection.
- Configure the devices using the integrated web server.



### NOTE

To transfer index changes via the WebUI and acyclic ISDU writes to the DataStorage, a ParamDownloadStore command must be sent after the index changes.

- The ParamDownloadStore command can be triggered by writing value 0x05 to index 0x02.

#### Configuration via EDS.

Once the EDS file has been imported into the Productivity software and configured, per [Section 7.1](#), the module configuration data can be found in Hardware Config – EtherNet/IP Client Properties -> CONFIG DATA tab.

In the “Value” column, change configuration parameters by typing in a new value, or selecting from a drop-down list (see the “IO-Link Port X0 - IO-Link Function Pin 4” parameter example in [Fig. 8-1](#)).

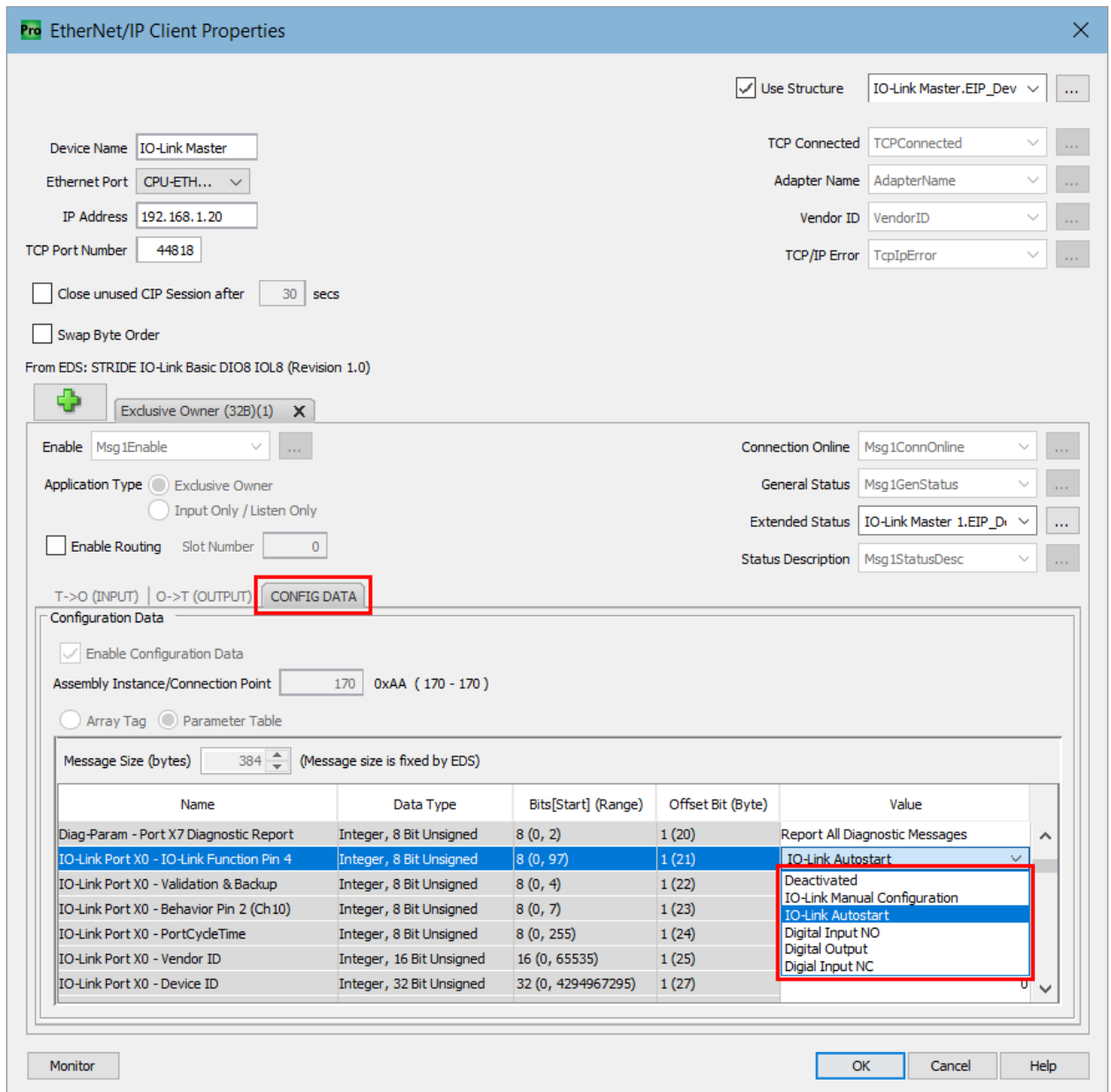

Fig. 8-1: EtherNet/IP Device Config Data.

Changes to configuration parameters must be transferred to the CPU.



**NOTE**

Configuration parameters are only transferred to the module during the Forward Open process and communication between the CPU and the module is briefly interrupted for configuration changes to take place.



**NOTE**

For more information on the adjustable parameter values, please refer to [Section 7.4.4, "Configuration values"](#).

## 8.2. RPI configuration

### Setting the RPI values

The RPI value is set in the EtherNet/IP Device properties, which is found in the **EtherNet/IP** tab of the **Hardware Config**.

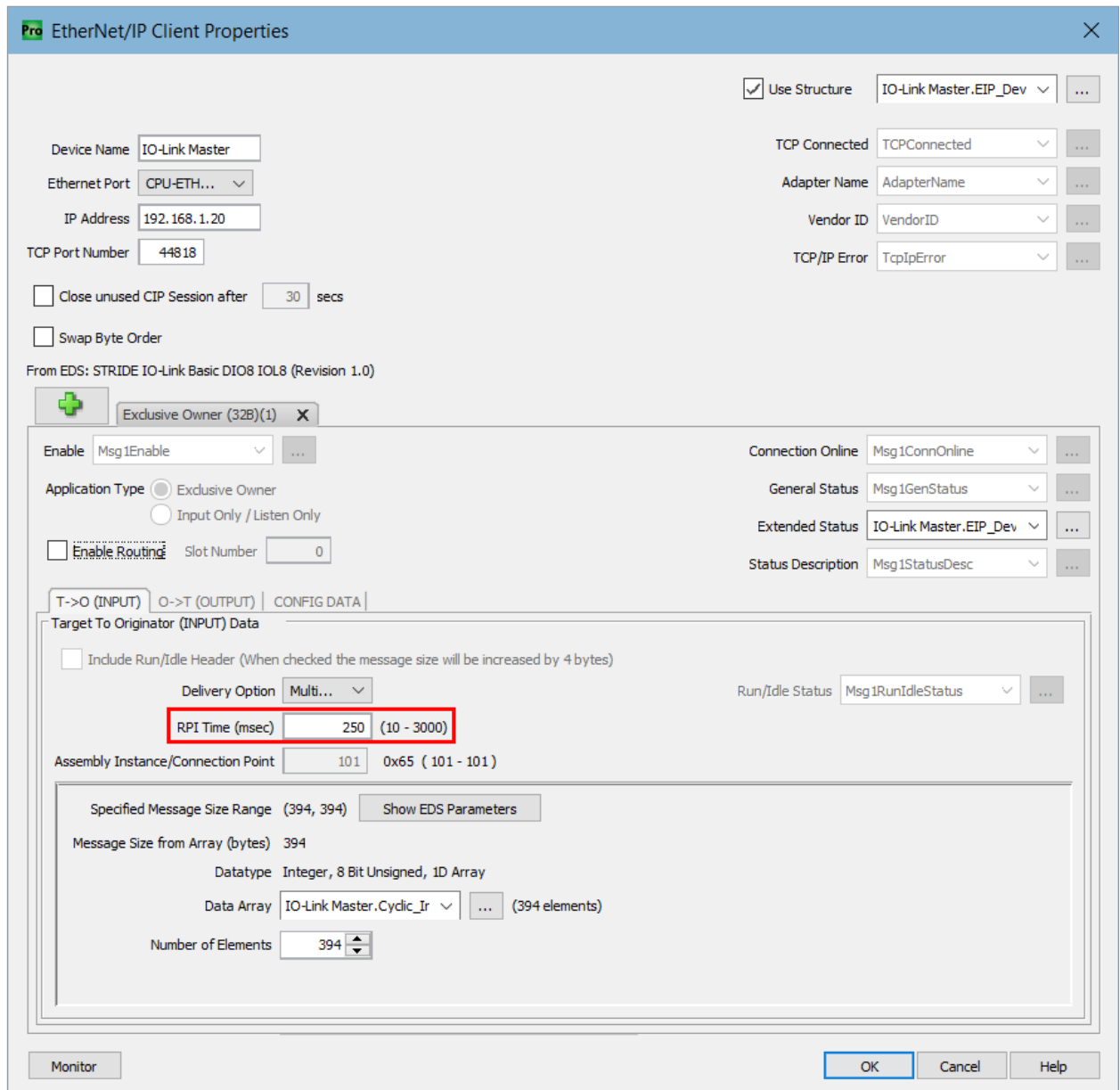

Fig. 8-2: EtherNet/IP Client Properties – T->O (Input) RPI Time.

The screenshot shows the 'O->T (OUTPUT)' tab of the 'CONFIG DATA' section. The 'Originator To Target (OUTPUT) Data' section has a checked box for 'Include Run/Idle Header'. The 'RPI Time (msec)' field is set to 250 and is highlighted with a red box. Below it, the 'Assembly Instance/Connection Point' is 111. A 'Specified Message Size Range' of (260, 260) is shown with a 'Show EDS Parameters' button. The 'Message Size from Array (bytes)' is 260, with a 'Datatype' of 'Integer, 8 Bit Unsigned, 1D Array'. The 'Data Array' is 'IO-Link Master.Cyclic\_C' with '(260 elements)'. The 'Number of Elements' is 260. At the bottom are 'Monitor', 'OK', 'Cancel', and 'Help' buttons.

Fig. 8-3: EtherNet/IP Client Properties – O->T (Output) RPI Time.



#### NOTE

The minimum allowed RPI is 1 ms.

## 8.3. IO-Link configuration

### IO-Link configuration

With the Basic IO-Link Master module, the IO-Link devices can be configured in two different ways:

- Explicit Messages in EtherNet/IP
- IO-Link Device Tool

### IO-Link device configuration through EtherNet/IP Explicit Messages

It is possible to configure the connected IO-Link devices through EtherNet/IP Explicit Messages.



For further information, please refer to [Section 9.2.1, “Diagnostics structure in the control system”](#).

### IO-Link Device Tool

The **IO-Link Device Tool** enables configuration of IO-Link devices via a graphical interface. The user can assign and set an IO-Link device for the IO-Link Master IO-Link port. The configuration can then be sent to the IO-Link device.

## 9. Operation

### 9.1. LED indication

The module has separate and clearly arranged indicators:

- LED indication for inputs and outputs
- LED indication for bus
- LED indication POWER
- Extended LED indications

The LEDs on the front panel of the module are labeled for clear identification of the displayed information.

#### 9.1.1. LED assignment to channel and pin

A separate status display is assigned to each input and output.

- LED 0 corresponds to pin 4.
- LED 1 corresponds to pin 2.

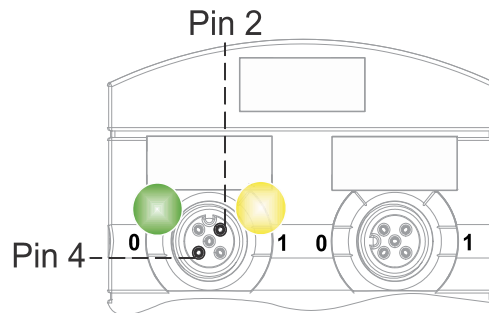

#### 9.1.2. LED flashing behavior

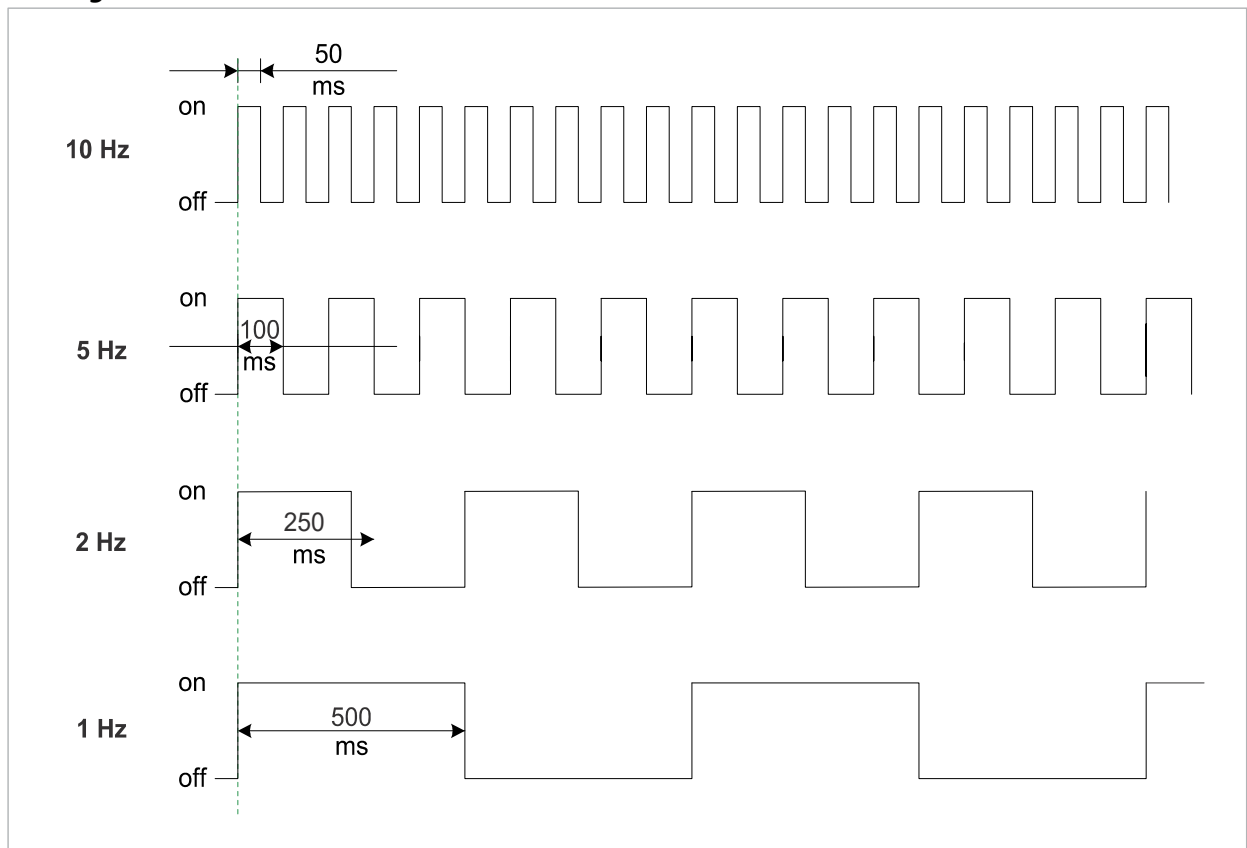
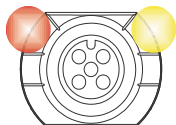





Fig. 9-1: LED flashing behavior.

### 9.1.3. LED indication for inputs and outputs







A separate status display is assigned to each input and output.

#### Pin 2 Digital Input DI

LED Indication DI Pin 2		
Indication	Condition	Description
 Yellow	Steady On	Fixed configuration: DI (NO) visible in process data. 24V
 Red	Flashing at 1Hz	Overload/short circuit in sensor supply 24V + Pin1
 Off	Off	Pin 2 is not used or deactivated



#### Pin 2 Digital Output DO

LED Indication DO Pin 2		
Indication	Condition	Description
 Yellow	Steady On	Fixed configuration: DO switchable via process data. 24V
 Red	Steady On	Overload/short circuit at pin 2
 Red	Flashing at 1Hz	Overload/short circuit in sensor supply 24V + Pin1
 Off	Off	Pin 2 is not used or deactivated





#### Error at Input or Output

If an error occurs at an input or output, the associated LED at the M12 port lights up red.









#### Pin 4 Digital Input DI

LED Indication DI Pin 4		
Indication	Condition	Description
 Yellow	Steady On	Fixed configuration: DI (NO) visible in process data. 24V
 Red	Flashing at 1Hz	Overload/short circuit in sensor supply 24V + Pin1
 Off	Off	Pin 4 is not used or deactivated

#### Pin 4 Digital Output DO

LED Indication DO Pin 4		
Indication	Condition	Description
 Yellow	Steady On	Fixed configuration: DO switchable via process data. 24V
 Red	Steady On	Overload/short circuit at pin 4
 Red	Flashing at 1Hz	Overload/short circuit in sensor supply 24V + Pin1
 Off	Off	Pin 4 is not used or deactivated



Pin 4 IO-Link Mode

LED Indication IO-Link Mode Pin 4		
Indication	Condition	Description
 Green	Steady On	IO-Link in Operate status
 Green	Flashing at 1 Hz	No IO-Link connection
 Green	Flashing at 10 Hz	IO-Link in the Pre-Operate status during data storage
 Red	Steady On	Overload/short circuit at pin 4
 Red	Flashing at 2 Hz	<ul style="list-style-type: none"> <li> Validation failed</li> <li> Incompatible IO-Link module connected for data storage</li> <li> Data storage failed</li> </ul>
 Off	Off	IO-Link connection deactivated



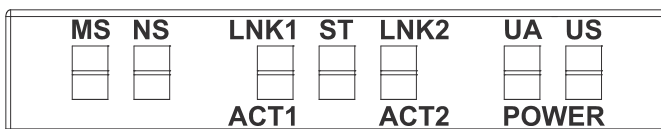



9.1.4. LED display MS and NS

LED-Indication Overview









-  NS (network status) - indicates the state of the fieldbus system
-  MS (module status) - indicates the state of the module in the PLC configuration

LED Indication MS

LED Indication MS		
Indication	Condition	Description
 Green	Steady on	Module in operation
 Green	Flashing at 1 Hz	Standby: The module has not been configured.
 Green/Red	Flashing at 1 Hz	Self-test
 Red	Flashing at 1 Hz	Major recoverable fault.*
 Red	Steady on	Major unrecoverable fault.**
 Off	Off	No power supply.

\* Incorrect or inconsistent configuration is considered a fatal correctable error.  
 \*\* If LED display is red, first check for an IP address conflict.

LED Indication NS

LED Indication NS		
Indication	Condition	Description
 Green	Steady on	Connection to the master available, IP address is being configured.
 Green	Flashing at 1 Hz	No connection to master. IP address is configured.
 Green/Red	Flashing at 1 Hz	Self-test
 Red	Flashing at 1 Hz	At least one connection has timed out.
 Red	Steady on	Double IP address: the module has detected that its IP address is already in use.*
 Off	Off	No power supply, or no configured IP address.

\* If LED display is red, first check for an IP address conflict.

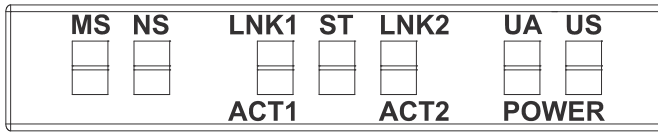

### 9.1.5. LED indication for LNK/ACT

#### LED-Indication Overview





- LNK/ACT (Link/Activity) indicate the state of EtherNet/IP communications at each port.

#### LED Indication LNK

LED Indication LNK		
Indication	Condition	Description
 Green	Steady on	Connection to network available.
 Off	Off	No connection to network.*
* If LED remains OFF, check the line connections.		

#### LED Indication ACT

LED Indication ACT		
Indication	Condition	Description
 Green	Flashing	The module is sending/receiving Ethernet frames
 Off	Off	The module is not sending/receiving Ethernet frames*



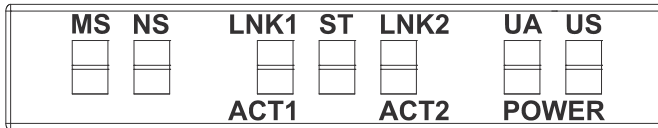

### 9.1.6. LED indication for State

#### LED-Indication Overview



- ST - indicates the state of the overall module.

#### LED Indication ST

LED Indication ST		
Indication	Condition	Description
 Green	Steady on	The regular firmware is running. Normal operation.
 Green	Flashing at 4 Hz	The operation requested by the position of the rotary switch is being performed. Do not switch off the device.
 Red	Flashing at 1 Hz	Invalid rotary switch position. The system will not start.
 Red	Steady on	Initialization error. Error during module initialization. <ul style="list-style-type: none"> <li>■ HW problems</li> <li>■ Missing valid configuration</li> <li>■ No COM FW found</li> <li>■ Rotary switch operation failed, etc.</li> </ul>

### 9.1.7. LED indication for POWER US and UA



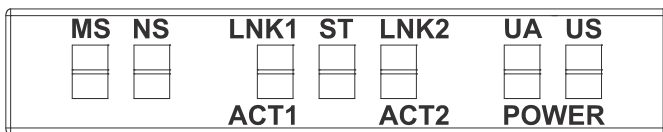

#### LED-Indication Overview



The power LEDs indicate the state of the supply voltages.

- UA actuator voltage
- US operating voltage

#### LED Indication POWER US





LED Indication POWER US		
Indication	Condition	Description
 Green	Steady on	18V ≤ US ≤ 30V Error-free operation
 Red	Steady on	11V ≤ US ≤ 18V Undervoltage
 Red	Flashing at 4 Hz	US > 30V Overvoltage
 Off	Off	US < 11V No voltage



#### NOTE

At US < 18V, an error-free operation is no longer guaranteed.

#### LED Indication POWER UA

LED Indication POWER UA		
Indication	Condition	Description
 Green	Steady on	18V ≤ UA ≤ 30V Error-free operation
 Red	Steady on	11V ≤ UA ≤ 18V Undervoltage
 Red	Flashing at 4 Hz	UA > 30V Overvoltage
 Off	Off	UA < 11V No voltage

### 9.1.8. Extended LED indication

#### LED-Indication Overview

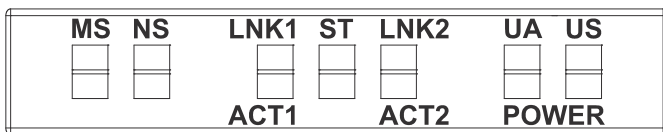

#### Extended LED display, identification of the module

Extended LED Display, Identification of the Module			
LED	Indication	Condition	Description
MS NS ST POWER UA POWER US	Green	Flashing at 1 Hz	Identification of the module

#### Extended LED display, factory reset

Extended LED Display, Factory Reset			
LED	Indication	Condition	Description
ST	Green	Steady on	Factory reset has been completed successfully
	Red	Steady on	Factory reset has been completed with failure
	Green	Flashing at 4 Hz	Factory reset in progress

## 9.2. Diagnostics

### 9.2.1. Diagnostics structure in the control system

Diagnostics Structure In The Control System		
Byte	Condition	Description
0	Last octet of the IP address of the device	Last octet of the IP address of the device
1	IO-Link identification	<b>0</b> = Default Code <b>0x40</b> = IO-Link Master Event Code <b>0x41</b> = IO-Link Device Event Code <b>0x42</b> = Murrelektronik IO-Link Device Event Code
2	Master channel number where the error occurred	
3	Device channel number where the error occurred	Only available if the IO-Link identification (Byte1) is set to the value 0x42
4	ErrorCode Byte1	For IO-Link, this is the LSB of the IO-Link ErrorCode, otherwise it is the Global Error Code, see the "Short-circuit diagnostic (Global Error Code 0x01)" table.
5	ErrorCode Byte2	For IO-Link, this is the MSB of the IO-Link ErrorCode, otherwise it is the Specific Error Code, see the "Short-circuit diagnostic (Global Error Code 0x01)" table.
6	Severity and active/inactive display	Bit 0: <ul style="list-style-type: none"> <li>■ 0 = Inactive diagnostic</li> <li>■ 1 = Active diagnostic</li> </ul> Bit 6 and 7: <ul style="list-style-type: none"> <li>■ 1 = Minor fault</li> <li>■ 2 = Major fault</li> <li>■ 3 = Information</li> </ul>
7	Reserved	0

### 9.2.2. Diagnostics in the WebUI

#### Diagnostic monitoring

The module diagnostics may also be monitored using the diagnostic page of the integrated WebUI.



#### Representation

Module status is displayed as the text descriptions in the tables below:

**Key:** indicates the type of diagnostic



**Description:** shows a more detailed description of the error

**Severity:** distinguishes 3 error categories:

- **Information** 
- **Warning** 
- **Defect** 

**Type:** this shows whether the diagnostic has just occurred or the fault has already been eliminated.

There are two types of diagnostics.

- **Active** 
- **Inactive** 

### 9.2.3. Diagnostic value

#### 9.2.3.1. Short-circuit diagnostic

Short-circuit Diagnostic (Global Error Code 0x01)	
Description	Value
Sensor Short Circuit	0x01
Actuator Warning	0x17
Actuator Short Circuit	0x18

#### 9.2.3.2. Undervoltage diagnostic

Undervoltage Diagnostic (Global Error Code 0x02)	
Description	Value
Undervoltage Actuator Power Supply	0x28
No Voltage Actuator Power Supply	0x29
Undervoltage External Actuator Power Supply	0x2A
No Voltage External Actuator Power Supply	0x2B
Undervoltage Sensor Power Supply	0x32
No Voltage Sensor Power Supply	0x33
Undervoltage U1	0xD0
Undervoltage U2	0xD1

#### 9.2.3.3. Overvoltage diagnostic

Overvoltage Diagnostic (Global Error Code 0x03)	
Description	Value
Overvoltage Actuator Power Supply	0x2C
Overvoltage External Actuator Power Supply	0x2D
Overvoltage Sensor Power Supply	0x34
Overvoltage U1	0xD4
Overvoltage U2	0xD5

#### 9.2.3.4. General diagnostic

General Diagnostic (Global Error Code 0x09)	
Description	Value
Error	0x00
PLC Connection Of Exclusive Owner Timed Out	0x59

#### 9.2.3.5. Buffer overflow diagnostic

Buffer Overflow Diagnostic (Global Error Code 0xFF)	
Description	Value
Overflow	0xFF

### 9.2.3.6. IO-Link master diagnostic

IO-Link Master Diagnostic (Global Error Code 0x40)	
Description	Value
Error	0x0000
Error Fetching Extended Events	0x97FF
Startup Parameterization Error	0x9801
Wrong Device. Inspection Level Mismatch	0x9802
Process Data Mismatch	0x9803
Short Circuit At C/Q - Pin 4	0x9804
IO-Link PHY Overtemperature	0x9805
Short Circuit L+ - Pin1	0x9806
Undervoltage L+ - Pin1	0x9807
Device Event Overflow	0x9808
Backup Failed - Memory Out Of Range 2k	0x9809
Backup Inconsistency - Data Storage Index Not Available	0x980A
Backup Inconsistency - Data Storage Unspecific Error	0x980B
Backup Inconsistency - Upload Fault	0x980C
Parameter Inconsistency - Download Fault	0x980D
Port Class B Failure - Power Missing	0x980E
Short Circuit At Pin 2	0x980F
Revision Fault	0x9811
Compatibility Fault Vendor ID (IO-Link 1.0)	0x9812
Compatibility Fault Device ID (IO-Link 1.0)	0x9813
Compatibility Fault Vendor ID (IO-Link 1.1)	0x9814
Compatibility Fault Device ID (IO-Link 1.1)	0x9815
Serial Number Fault	0x9816
Generic Data Storage Fault	0x9817
Invalid Cycle Time	0xE000
Revision Fault- Incompatible Protocol Version	0xE001
Parameter Inconsistency - ISDU Batch Failed	0xE002
Device Not Available - Communication Lost	0xFF22
Invalid Backup - Data Storage Identification Mismatch	0xFF23
Invalid Backup - Data Storage Buffer Overflow	0xFF24
Invalid Backup - Data Storage Parameter Access Denied	0xFF25
Event Lost - Incorrect Event Signaling	0xFF31

## 9.2.3.7. IO-Link device diagnostic

IO-Link Device Diagnostic (Global Error Code 0x41)	
Description	Value
Error	0x0000
General Malfunction	0x1000
Temperature Fault	0x4000
Ambient Temperature: General Error	0x4100
Ambient Temperature: Over-Run	0x4110
Ambient Temperature: Under-Run	0x4120
Device Temperature: General Error	0x4200
Device Temperature: Over-Run	0x4210
Device Temperature: Under-Run	0x4220
Outside Temperature: General Error	0x4300
Outside Temperature: Over-Run	0x4310
Outside Temperature: Under-Run	0x4320
Device Hardware Fault	0x5000
Component Malfunction	0x5010
Non Volatile Memory Loss	0x5011
Batteries Low	0x5012
General Power Supply Fault	0x5100
Fuse Blown/Open	0x5101
Primary Supply Voltage Over-Run	0x5110
Primary Supply Voltage Under-Run	0x5111
Secondary Supply Voltage Fault	0x5112
Device Supply: Voltage Under-Run U3	0x5113
Device Supply: Voltage Under-Run U4	0x5114
Device Supply: Voltage Under-Run U5	0x5115
Device Supply: Voltage Under-Run U6	0x5116
Device Supply: Voltage Under-Run U7	0x5117
Device Supply: Voltage Under-Run U8	0x5118
Device Supply: Voltage Under-Run U9	0x5119
Device Supply: Short Circuit	0x5151
Device Supply: Error In Periphery	0x5160
Device Controller: General Error	0x5200
Device Control Section: General Error	0x5300
Device Power Section: General Error	0x5400
Device Power Section: Error In Output Driver	0x5410
Device Power Section: Fuse Blown/Open	0x5450
Device Power Section: Fuse Blown/Open S1	0x5451
Device Power Section: Fuse Blown/Open S2	0x5452
Device Power Section: Fuse Blown/Open S3	0x5453
Device Power Section: Fuse Blown/Open S4	0x5454
Device Power Section: Fuse Blown/Open S5	0x5455
Device Power Section: Fuse Blown/Open S6	0x5456
Device Power Section: Fuse Blown/Open S7	0x5457
Device Power Section: Fuse Blown/Open S8	0x5458
Device Power Section: Fuse Blown/Open S9	0x5459
Error In Additional Device Communication	0x5500
Error In Device Communication Interface 2	0x5510
table continued on next page	

<b>IO-Link Device Diagnostic (Global Error Code 0x41) (continued)</b>	
<b>Description</b>	<b>Value</b>
Device Software Fault	0x6000
Device Software: Reset (Watchdog)	0x6010
Device Software: Internal Fault	0x6100
Device Software: Dataset Error	0x6300
Loss Of Parameter	0x6310
Parameter Error	0x6320
Parameter Missing	0x6321
Parameter Not Initialized	0x6330
Parameter Not Specific	0x6340
Parameter Changed	0x6350
Wire Break Of A Subordinate Device	0x7700
Wire Break Of Subordinate Device 1	0x7701
Wire Break Of Subordinate Device 2	0x7702
Wire Break Of Subordinate Device 3	0x7703
Wire Break Of Subordinate Device 4	0x7704
Wire Break Of Subordinate Device 5	0x7705
Wire Break Of Subordinate Device 6	0x7706
Wire Break Of Subordinate Device 7	0x7707
Wire Break Of Subordinate Device 8	0x7708
Wire Break Of Subordinate Device 9	0x7709
Wire Break Of Subordinate Device 10	0x770A
Wire Break Of Subordinate Device 11	0x770B
Wire Break Of Subordinate Device 12	0x770C
Wire Break Of Subordinate Device 13	0x770D
Wire Break Of Subordinate Device 14	0x770E
Wire Break Of Subordinate Device 15	0x770F
Short Circuit	0x7710
Ground Fault	0x7711
Communication Monitoring: General Error	0x8100
Process Data Monitoring: General Error	0x8110
Technology Specific Application Fault	0x8C00
Simulation Active	0x8C01
Process Variable Range Over-Run	0x8C10
Measurement Range Over-Run	0x8C20
Process Variable Range Under-Run	0x8C30
Maintenance Required - Cleaning	0x8C40
Maintenance Required - Refill	0x8C41
Maintenance Required - Wear And Tear	0x8C42

## 9.3. Acyclic IO-Link device access

### IO-Link Device Parameter Object (Class Code 0x83)

The fieldbus device allows connected IO-Link devices to be configured with acyclic write and read access using the IO-Link Device Parameter Object (Class Code 0x83).

The IO-Link Device Parameter Object can be used to access parameters of an IO-Link device via ISDU (Index Service Data Unit). The object provides services that map CIP services to IO-Link services. An IO-Link port is addressed via the CIP instance of the "IO-Link Device Parameter Object".

#### 9.3.1. Reading an IO-Link device index

##### Read ISDU Request

###### Read IO-Link device index

- To read the index of a connected IO-Link device, use the EtherNet/IP service Read\_ISDU 75 (0x4B).
- Send the service to the correct attribute/instance of the IO-Link device parameter object (class code 0x83).
- An attribute/instance represents the IO-Link port to which the IO-Link device is connected.

Structure Of A Read ISDU Service Request			
Name	Value	Type	Description
CIP Service	75 (0x4B)	-	ISDU read service
CIP Class	131 (0x83)	-	IO-Link Device Parameter Object
CIP Instance	1 ... Number of available IO-Link Ports	-	Addresses the IO-Link Port to which the IO-Link device is connected.
CIP Data	Index	UINT	IO-Link ISDU object index
	Subindex	USINT	IO-Link ISDU object subindex

##### Read ISDU Response

Positive Response (CIP Status In Service Response == 0)			
Name	Value	Type	Description
CIP Service	75 (0x4B)	-	ISDU read service
CIP Class	131 (0x83)	-	IO-Link Device Parameter Object
CIP Instance	1 ... Number of available IO-Link Ports	-	Addresses the IO-Link Port to which the IO-Link device is connected.
CIP Data	ISDU Data	ARRAY of BYTE	IO-Link object data retrieved from the IO-Link device. Maximum number of bytes: 232

Negative Response (CIP Status In Service Response != 0)			
Name	Value	Type	Description
CIP Service	75 (0x4B)	-	ISDU read service
CIP Class	131 (0x83)	-	IO-Link Device Parameter Object
CIP Instance	1 ... Number of available IO-Link Ports	-	Addresses the IO-Link Port to which the IO-Link device is connected.
CIP Data	The structure of the error codes can be found in <a href="#">Section 9.3.3. "CIP status codes"</a>	UINT	IO-Link Master Error
		USINT	IO-Link Device Error
		USINT	IO-Link Device Additional Error Code

### 9.3.2. Writing an IO-Link device index

#### Write ISDU Request

##### Writing an IO-Link device index

- To write to the index of a connected IO-Link device, use the EtherNet/IP service Write\_ISDU 76 (0x4C).
- Send the service to the correct attribute of the IO-Link device parameter object (class code 0x83).
- An attribute represents the IO-Link port to which the IO-Link device is connected.

##### Structure of a write ISDU service request

Structure Of A Write ISDU Service Request			
Name	Value	Type	Description
CIP Service	76 (0x4C)	-	ISDU write service
CIP Class	131 (0x83)	-	IO-Link Device Parameter Object
CIP Instance	1 ... Number of available IO-Link Ports	-	Addresses the IO-Link Port to which the IO-Link device is connected.
CIP Data	Index	UINT	IO-Link ISDU object index
	Subindex	USINT	IO-Link ISDU object subindex
	Data	ARRAY of BYTE	Data that shall be written to IO-Link device. Maximum number of bytes: 232

#### Write ISDU Response

##### Positive Response (CIP Status in service response == 0)

The positive response to this service does not hold any CIP data.

Positive Response (CIP Status In Service Response == 0)			
Name	Value	Type	Description
CIP Service	76 (0x4C)	-	ISDU write service
CIP Class	131 (0x83)	-	IO-Link Device Parameter Object
CIP Instance	1 ... Number of available IO-Link Ports	-	Addresses the IO-Link Port to which the IO-Link device is connected.
CIP Data	The positive response to this service does not hold any CIP Data (Number of bytes: 0).		

##### Negative Response (CIP Status in service response != 0)

Negative Response (CIP Status In Service Response != 0)			
Name	Value	Type	Description
CIP Service	76 (0x4C)	-	ISDU read service
CIP Class	131 (0x83)	-	IO-Link Device Parameter Object
CIP Instance	1 ... Number of available IO-Link Ports	-	Addresses the IO-Link Port to which the IO-Link device is connected.
CIP Data	The structure of the error codes can be found in <a href="#">Section 9.3.3. "CIP status codes"</a>	UINT	IO-Link Master Error
		USINT	IO-Link Device Error
		USINT	IO-Link Device Additional Error Code

### 9.3.3. CIP status codes

#### CIP error codes

The following table provides a brief overview of which CIP status code can be returned when accessing the “IO-Link Device Parameter Object” via a CIP service. The table does not claim to be complete.

CIP Status Codes	
Name	Description
0 (0x00)	Success. Service was successfully performed.
5 (0x05)	Path destination unknown. Addressed CIP Class or CIP Instance is not known.
8 (0x08)	Service not supported. The requested service is not implemented or was not defined for this Object Class/Instance.
19 (0x13)	Not enough data. The service did not supply enough data to perform the specified operation.
20 (0x14)	Attribute not supported. The attribute specified in the request is not supported.
21 (0x15)	Too much data. The service supplied more data than was expected.
30 (0x1E)	An embedded service resulted in an error. The IO-Link specific error codes within the CIP response data might provide more information about what went wrong.

## 10. Web Server (WebUI)

The Murrelektronik web server (WebUI) is a graphic tool that you can use to obtain information about the device quickly and intuitively.

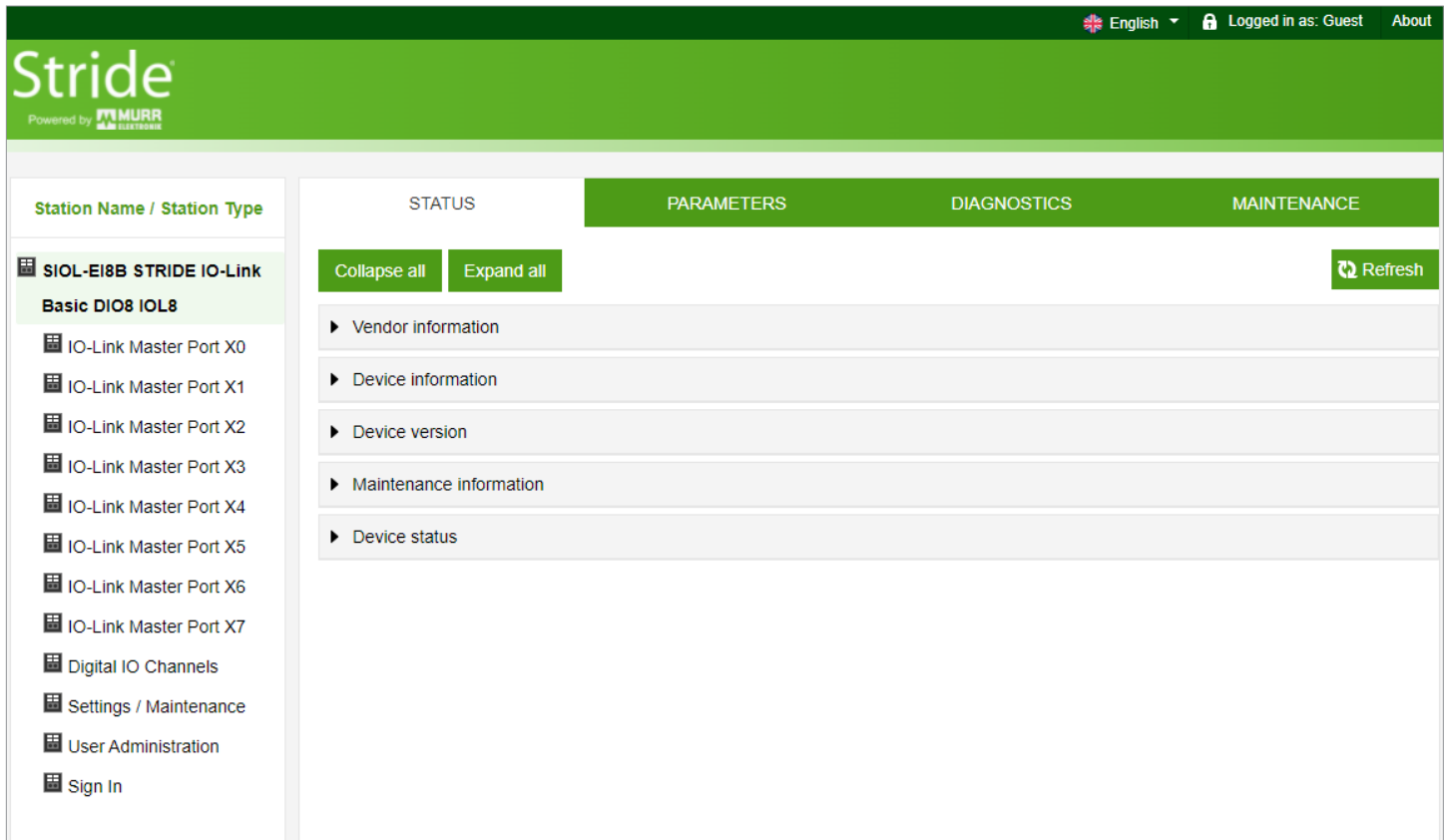

Fig. 10-1: The Murrelektronik WebUI.

The devices shown in the screenshots serve as examples.

## 10.1. Starting the WebUI

### Prerequisites

Prerequisite for a correct graphic display of the WebUI:

→ Current versions of the following browsers are supported:

- Mozilla Firefox
- Microsoft Edge
- Google Chrome

To start the WebUI, proceed as follows:

- Start the web browser.
- Enter the IP address of the device in the web browser.  
*The WebUI startup screen is the “Status” page.*

### Operating areas

The WebUI is divided into 4 operating areas.

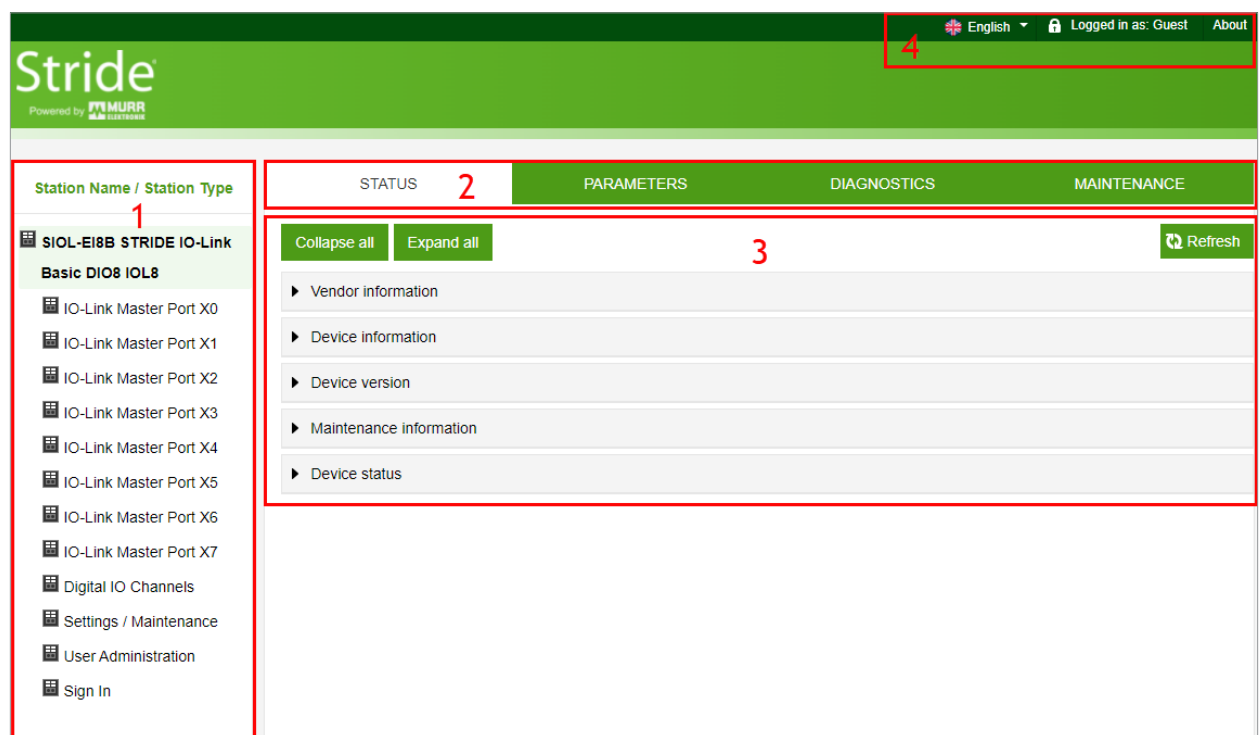

Fig. 10-2: Operating areas.

1. **System tree**  
Shows the device and the available sub-functions.
2. **Menu bar**  
The menu bar enables you to switch between the different pages of the device or the sub-function. In addition, the white tab highlights the current page.
3. **Page content**  
This area shows the contents of the selected page.
4. **Header bar**  
Language and interface settings, system information.

## 10.2. Menu bar

In the first line of the system tree, the device is displayed with part number and product name.

The menu bar comprises the following clickable menu items:

- Status
- Parameters
- Diagnostics
- Maintenance

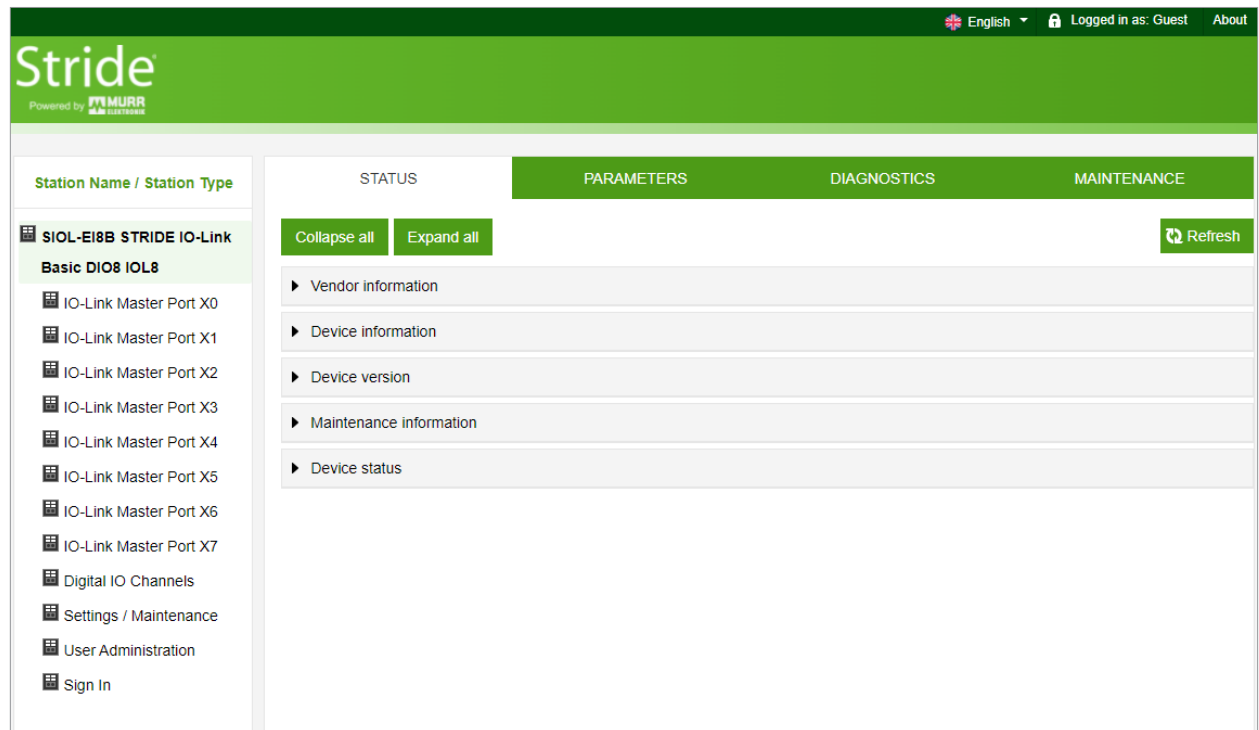

Fig. 10-3: Menu bar.

### 10.2.1. STATUS menu

The “Status” menu item contains the following subitems:

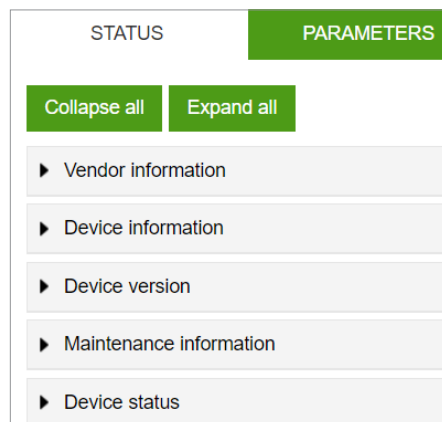

Fig. 10-4: Menu item “Status”.

## Vendor information

“Vendor information” displays the following information:

Vendor Information	
Parameter designation	Meaning
Vendor name	Fixed data
Vendor address	Fixed data
Vendor phone	Fixed data
Vendor URL	Manufacturer website

## Device information

“Device information” displays the following information:

Device Information	
Parameter designation	Meaning
Order number	Part number of the device
MAC address	Fixed MAC address of the device
Hardware name	Fixed product name of the device
Software name	Fieldbus designation of the device
Serial number	Serial number of the device

## Device version

“Device version” displays the following information:

Device Version	
Parameter designation	Meaning
Hardware version	Design version of the hardware
Software version	Currently running software version in the device
Webpage version	Currently running version of the web server (WebUI) in the device

## Maintenance information



### NOTE

The maintenance information here is read-only. Any entry or changes to the fields is done via “Settings/Maintenance → Maintenance information”.

“Maintenance information” displays the following information:

Maintenance Information	
Parameter designation	Meaning
Name	Name of the device, free text
Installation location	Location name, free text
Contact information	Contact, free text
Description	Description, free text
Last service date (yyyy-mm-dd)	Free date entry
Next service date (yyyy-mm-dd)	Free date entry

## Device status

“Device status” displays the following information:

Device Status	
Parameter designation	Meaning
Sensor supply voltage (US)	Display of the sensor voltage in Volts
Sensor supply current (IS)	Display of the sensor current in Amperes
Temperature	Display of internal device temperature in degrees Celsius
Total operating time [dddd:hh:mm:ss]	Total operating time since first startup
Number of startups	Number of device restarts

### 10.2.2. PARAMETERS menu

The “Parameters” menu item contains the following subitems, which are read-only:

- Diagnostic configuration
- IO layout for digital channels

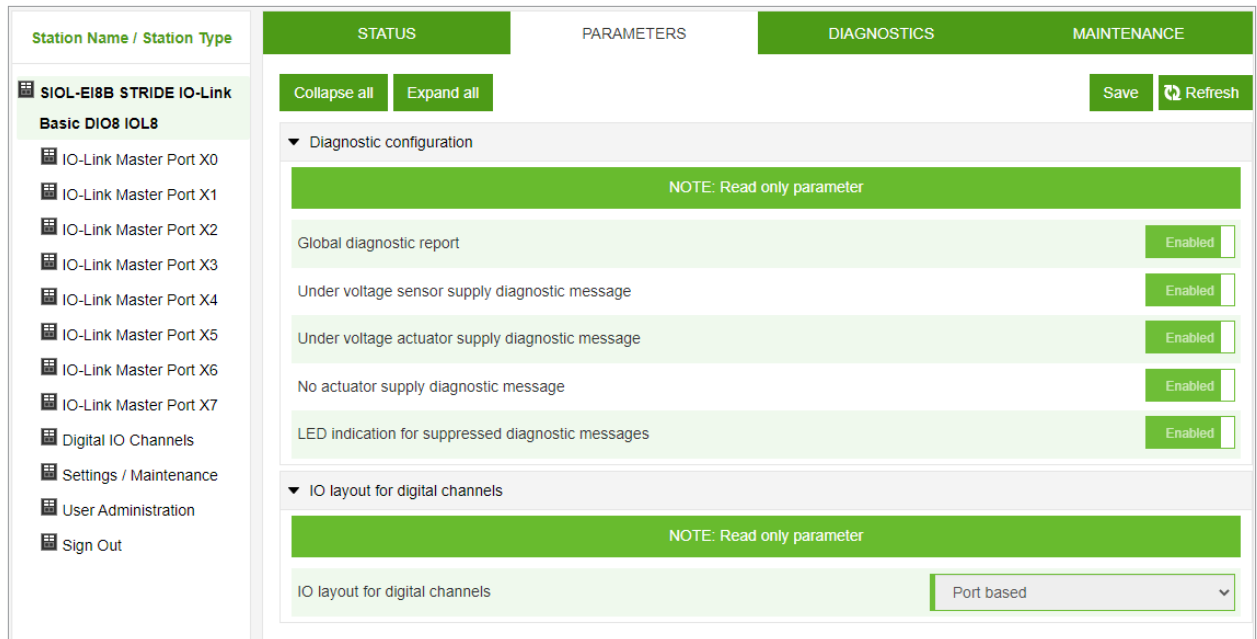

Fig. 10-5: Menu item “Parameters”.

### 10.2.3. DIAGNOSTICS menu

The “Diagnostics” menu item shows the incoming and outgoing alarms of the master.

The menu shows an overview of diagnostic messages.

Depending on the setting in the “Please select an entry” drop-down menu, the following diagnostics of the module are displayed:

- Active
  - ✓ All diagnostics pending at the time of the WebUI call.
  - ✓ All diagnostics that are no longer active are not displayed.
- History
  - ✓ All diagnostics that are no longer active are placed in the diagnostic memory log and are displayed.
  - ✓ The module can hold up to 40 historical diagnostic entries. The most recent diagnostic entry overwrites the oldest one in the memory.

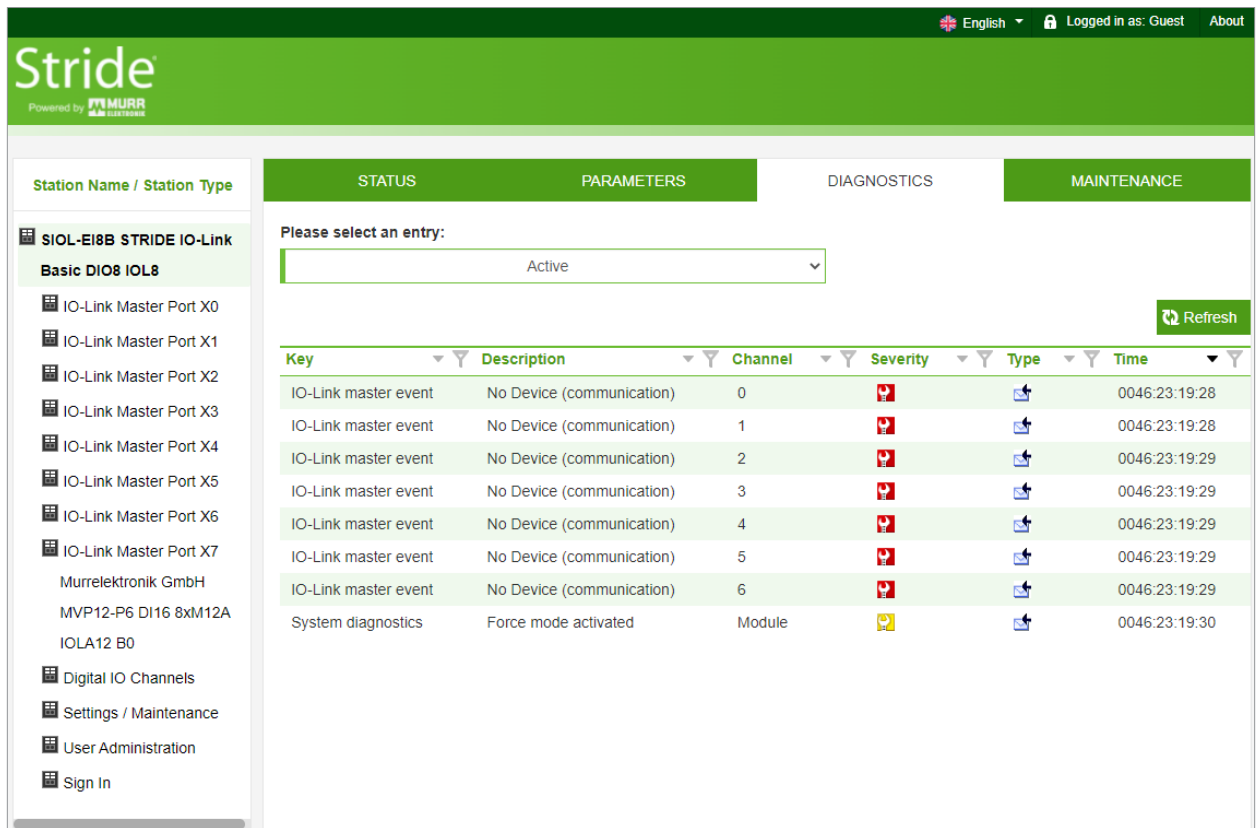

Fig. 10-6: Menu item "Diagnostics".

### 10.2.4. MAINTENANCE menu

In the "Maintenance" menu item, users with admin and operator rights can erase the diagnostic memory.

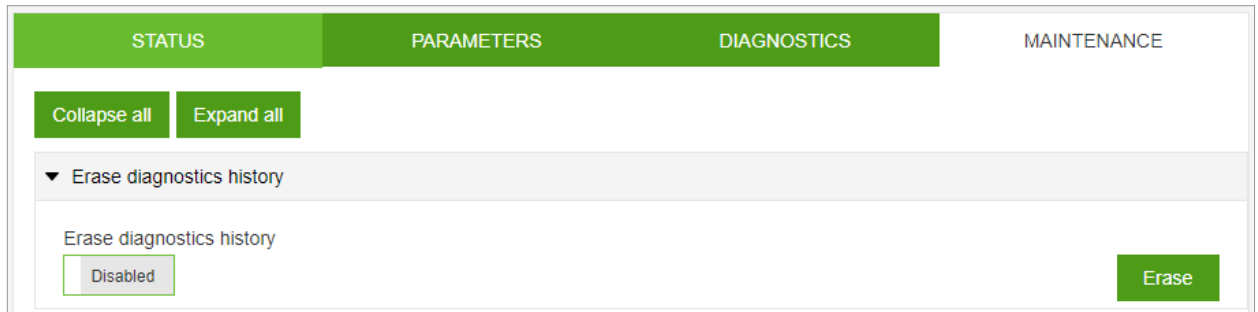

Fig. 10-7: Erasing the diagnostic memory.

### 10.3. IO-Link Master Port

The system tree displays 8 IO-Link master ports (X0 ... X7) that can be selected individually. Depending on the user role, information can be read or functions can be configured here. When IO-Link communication is active, the IO-Link device name automatically appears under the relevant port.

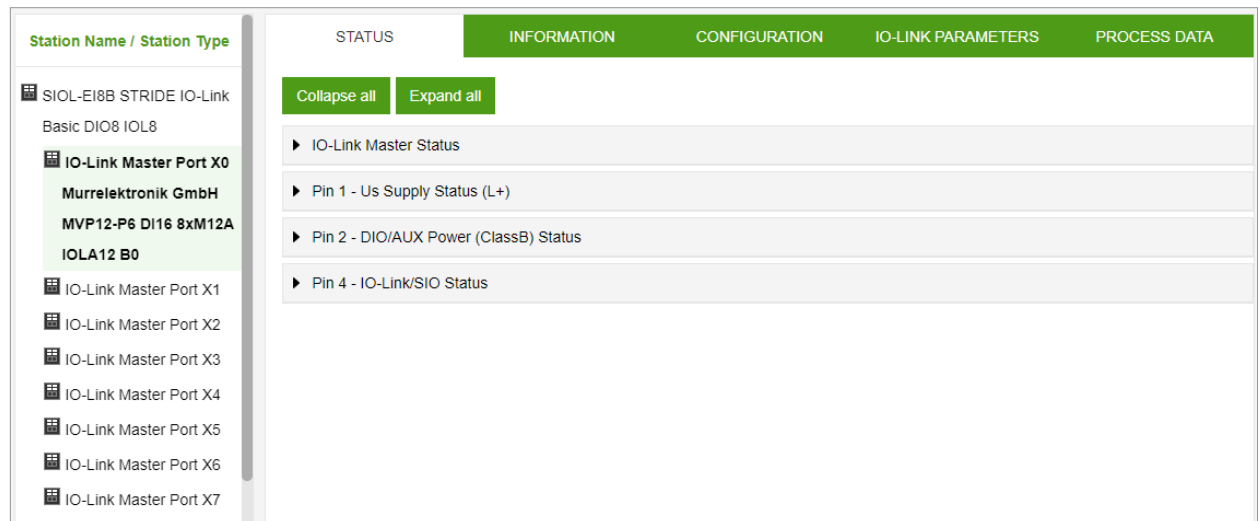

Fig. 10-8: IO-Link master port.

#### 10.3.1. STATUS menu

The IO-Link master status is displayed here in the Status menu.

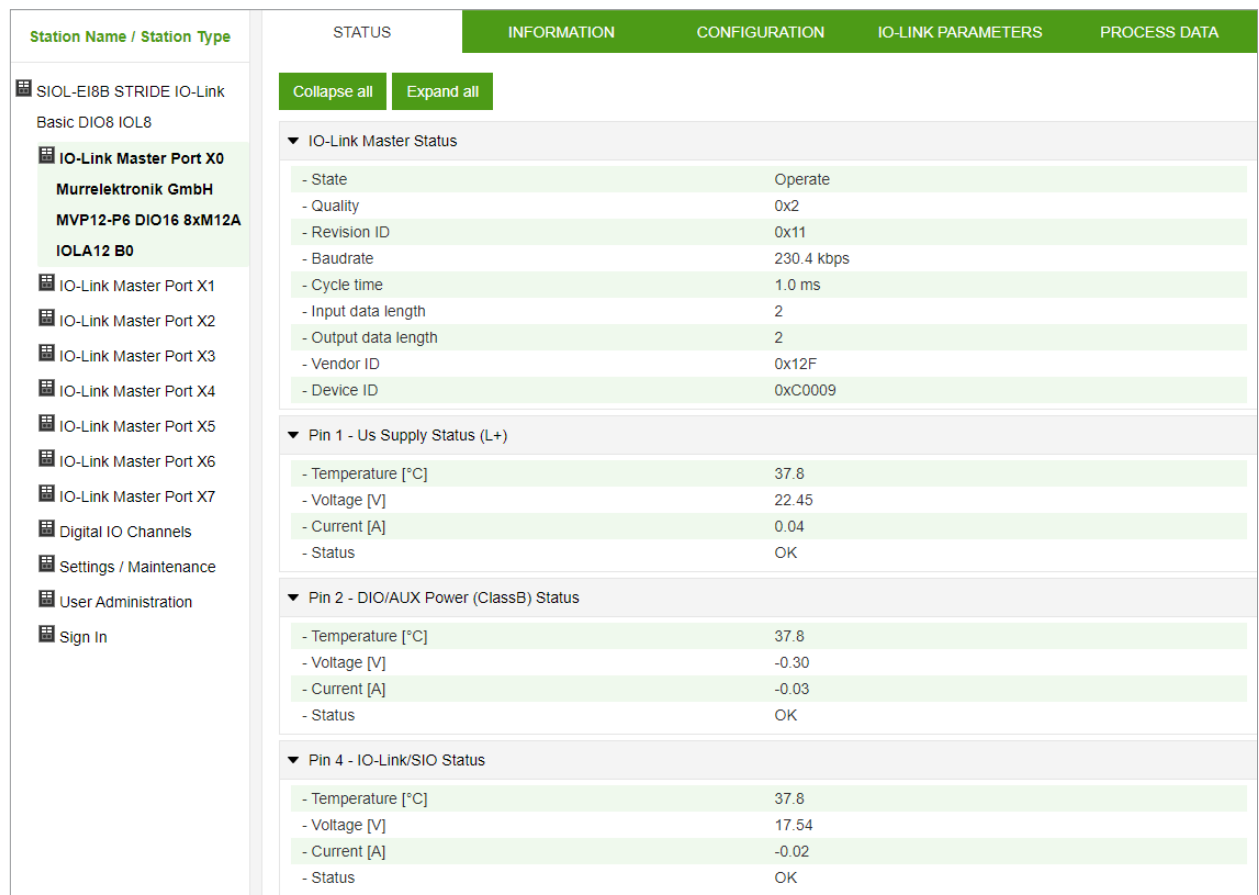

Fig. 10-9: IO-Link master port – IO-Link master status.

If pin 4 is in IO-Link operation, all relevant IO-Link data including the I/O bytes of the device are displayed, as shown in Fig. 10-9 above.

If pin 4 is in operation without a connected IO-Link device, a message appears indicating that no device is connected.

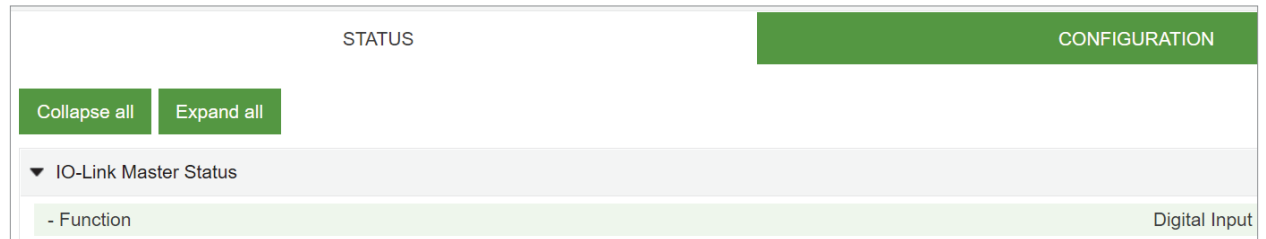

Fig. 10-10: IO-Link master port – IO-Link master status in digital operation.

If pin 4 is configured as a digital input, for example, this is also indicated here (see Fig. 10-10).

Possible displays are:

- Status: Deactivated
- Status: Digital input
- Status: Digital output

#### Port Status - pin 1

“Port Status - pin 1” displays the following information:

Port Status - Pin 1	
Parameter designation	Meaning
Temperature [°C]	Temperature in degrees Celsius
Voltage [V]	Voltage in Volts
Current [A]	Current in Amperes
Status	State of the pin

#### Port Status - pin 2

“Port Status - pin 2” displays the following information:

Port Status - Pin 2	
Parameter designation	Meaning
Temperature [°C]	Temperature in degrees Celsius
Voltage [V]	Voltage in Volts
Current [A]	Current in Amperes
Status	State of the pin

#### Port Status - pin 4

“Port Status - pin 4” displays the following information:

Port Status - Pin 4	
Parameter designation	Meaning
Temperature [°C]	Temperature in degrees Celsius
Voltage [V]	Voltage in Volts
Current [A]	Current in Amperes
Status	State of the pin

### 10.3.2. INFORMATION menu

The “Information” menu item contains the following subitems:

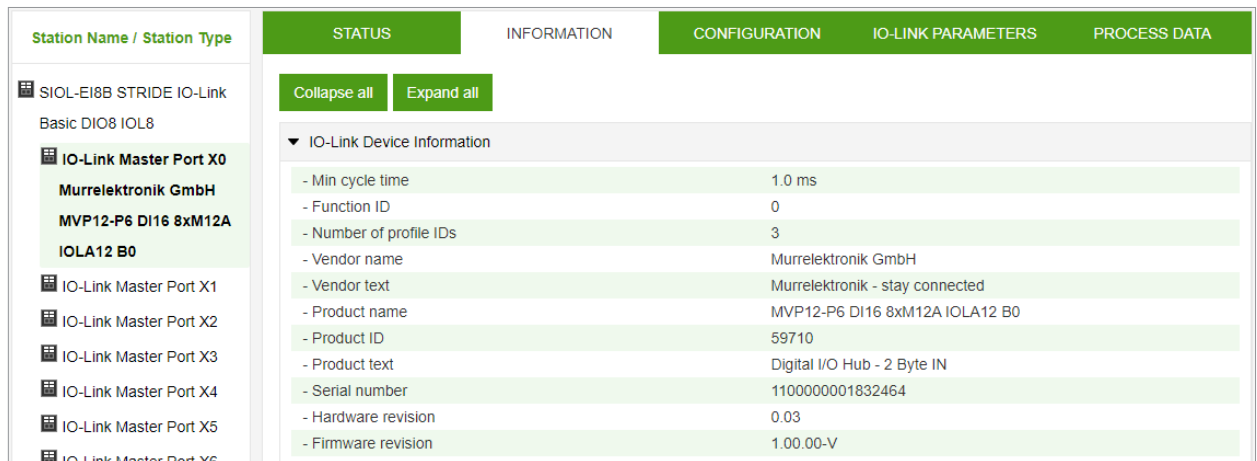

Station Name / Station Type	STATUS	INFORMATION	CONFIGURATION	IO-LINK PARAMETERS	PROCESS DATA
SIOL-EI8B STRIDE IO-Link					
Basic DIO8 IOL8					
<b>IO-Link Master Port X0</b>					
Murrelektronik GmbH					
MVP12-P6 DI16 8xM12A					
IOLA12 B0					
IO-Link Master Port X1					
IO-Link Master Port X2					
IO-Link Master Port X3					
IO-Link Master Port X4					
IO-Link Master Port X5					
IO-Link Master Port X6					

IO-Link Device Information	
- Min cycle time	1.0 ms
- Function ID	0
- Number of profile IDs	3
- Vendor name	Murrelektronik GmbH
- Vendor text	Murrelektronik - stay connected
- Product name	MVP12-P6 DI16 8xM12A IOLA12 B0
- Product ID	59710
- Product text	Digital I/O Hub - 2 Byte IN
- Serial number	110000001832464
- Hardware revision	0.03
- Firmware revision	1.00.00-V

Fig. 10-11: IO-Link master port – “Information”.

#### IO-Link device information

The technical data and manufacturer information of a connected and active IO-Link device at the corresponding master port are displayed here.

“IO-Link device information” displays the following information:

IO-Link Device Information	
Parameter designation	Meaning
Min. cycle time	Minimum process cycle time of the IO-Link device
Function ID	Function ID of the IO-Link device
Number of profile IDs	Number of profiles supported by the IO-Link device
Vendor name	Name of the IO-Link device manufacturer
Vendor text	Manufacturer text of the IO-Link device
Product name	Product name of the IO-Link device
Product ID	Article number of the IO-Link device
Product text	Additional description of the IO-Link device
Serial number	Serial number
Hardware version	Hardware version
Firmware version	Firmware version

### 10.3.3. CONFIGURATION menu

In the “Configuration” menu item of the selected IO-Link port, the setting for pin 1, pin 2 and pin 4 is indicated at the selected port.

Users can only view the current settings of pin 1, pin 2 and pin 4.

Pin 1, pin 2 and pin 4 settings can only be changed by a controller (via EDS file or Explicit Messaging) or with the Device Tool software.

Refer to Section 7.4.4 for configuration values.

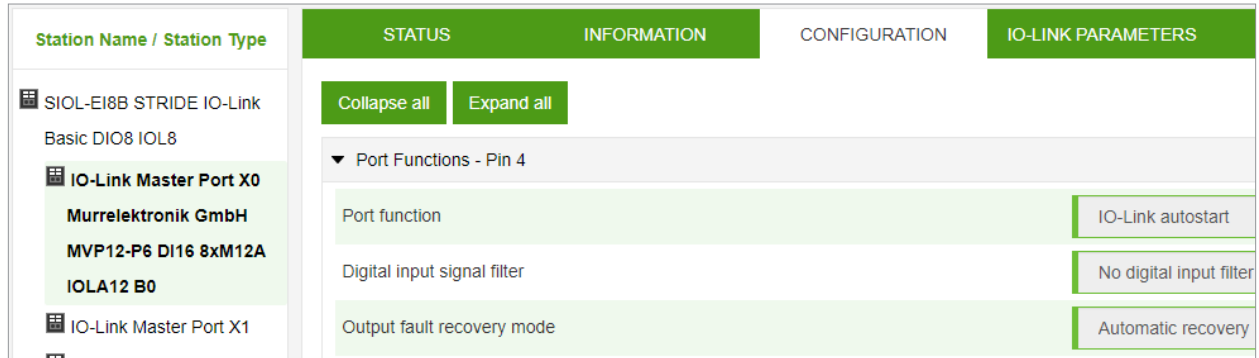

Fig. 10-12: IO-Link master port – configuration (pin 4).

### 10.3.4. IO-LINK PARAMETER menu

In this menu item, the ISDU (Index Service Data Unit) of the device can be read during IO-Link operation. This allows an IO-Link device to be accessed (read-only) without a controller. The user is able enter the hexadecimal index and subindex values of the parameter to be accessed and view the returned device data in either hexadecimal or ASCII format.



#### NOTE

Observe the information in the IO-Link device manufacturer’s manual.

Users with maintenance and admin rights and users with service rights can only read ISDU values.

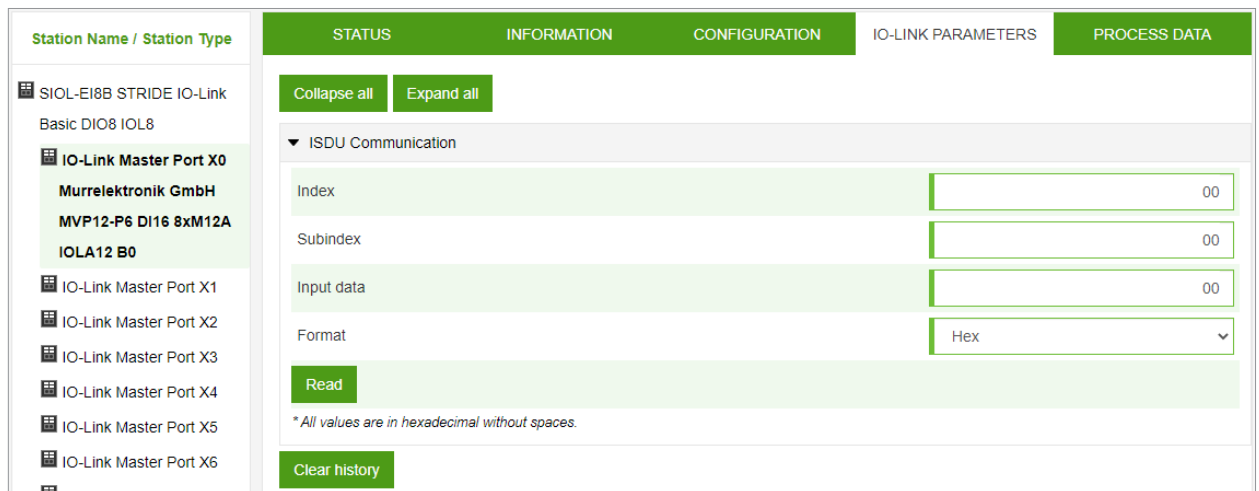

Fig. 10-13: IO-Link master port – IO-LINK PARAMETER.

### 10.3.5. PROCESS DATA menu

In the “Process data” menu item, the current process data of the connected IO-Link device is continuously displayed if pin 4 of the corresponding port has been configured as an IOL port. Example: port X2: pin 4 (IO-Link autostart) and pin 2 (digital output statically on).

Station Name / Station Type	STATUS	INFORMATION	CONFIGURATION	IO-LINK PARAMETERS	PROCESS DATA
SIOL-EI8B STRIDE IO-Link Basic DIO8 IOL8 IO-Link Master Port X0 IO-Link Master Port X1 <b>IO-Link Master Port X2</b> Murrelektronik GmbH MVP12-P6 DI16 8xM12A IOLA12 B0 IO-Link Master Port X3 IO-Link Master Port X4	Collapse all		Expand all		
	▼ Process Data				
	Pin 4 IOL Input	00,00			
	Pin 4 IOL Output	not available			
	Pin 2 DO	0			
	Pin 2 DI	0			
	* Values are in hexadecimal.				

Fig. 10-14: IO-Link master port – PROCESS DATA.

In this menu item the current states of the digital inputs are displayed. Example: port X1: pin 4 (DI) and pin 2 (DI).

Station Name / Station Type	STATUS	CONFIGURATION	PROCESS DATA	
SIOL-EI8B STRIDE IO-Link Basic DIO8 IOL8 IO-Link Master Port X0 <b>IO-Link Master Port X1</b> IO-Link Master Port X2 IO-Link Master Port X3 IO-Link Master Port X4 IO-Link Master Port X5	Collapse all		Expand all	
	▼ Process Data			
	Pin 4 DI	0		
	Pin 2 DO	0		
	Pin 2 DI	0		
	* Values are in hexadecimal.			

Fig. 10-15: IO-Link master port – digital inputs – PROCESS DATA.

## 10.4. Settings / Maintenance

### 10.4.1. DEVICE CONFIGURATION menu

Users can change the IP settings of this device through the web server (WebUI).



#### NOTE

Factory default IP address setting for the module is DHCP.

The “Settings / Maintenance” - “Device Configuration” menu allows users to configure a static IP address, subnet mask, and gateway.

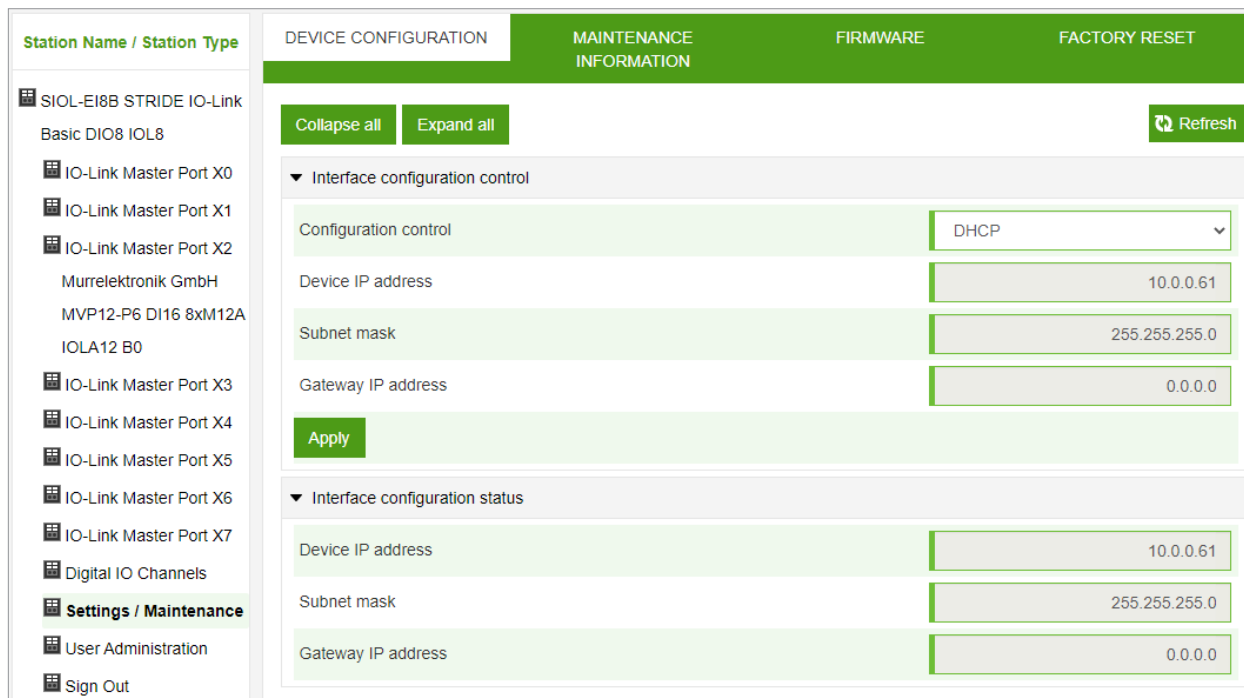

The screenshot shows the 'DEVICE CONFIGURATION' menu in the Stride WebUI. The left sidebar lists various station types, with 'Settings / Maintenance' selected. The main content area is divided into two sections: 'Interface configuration control' and 'Interface configuration status'. In the 'control' section, the 'Configuration control' is set to 'DHCP'. Below it, the 'Device IP address' is 10.0.0.61, the 'Subnet mask' is 255.255.255.0, and the 'Gateway IP address' is 0.0.0.0. An 'Apply' button is visible. The 'status' section shows the same values for the current configuration.

Station Name / Station Type	DEVICE CONFIGURATION	MAINTENANCE INFORMATION	FIRMWARE	FACTORY RESET
SIOL-EI8B STRIDE IO-Link	Collapse all   Expand all   Refresh			
Basic DIO8 IOL8	▼ Interface configuration control			
IO-Link Master Port X0	Configuration control	DHCP		
IO-Link Master Port X1	Device IP address	10.0.0.61		
IO-Link Master Port X2	Subnet mask	255.255.255.0		
Murrelektronik GmbH	Gateway IP address	0.0.0.0		
MVP12-P6 DI16 8xM12A	Apply			
IOLA12 B0	▼ Interface configuration status			
IO-Link Master Port X3	Device IP address	10.0.0.61		
IO-Link Master Port X4	Subnet mask	255.255.255.0		
IO-Link Master Port X5	Gateway IP address	0.0.0.0		
IO-Link Master Port X6				
IO-Link Master Port X7				
Digital IO Channels				
<b>Settings / Maintenance</b>				
User Administration				
Sign Out				

Fig. 10-16: IP address EtherNet/IP settings.

Clicking “Apply” sets the module IP configuration to the settings shown in the WebUI. If the module IP configuration is set to “STATIC”, it can be changed to “BOOTP” or “DHCP” from this menu.

### 10.4.2. MAINTENANCE INFORMATION menu

Users with service, maintenance and admin rights can enter the device information here.

Station Name / Station Type	DEVICE CONFIGURATION	MAINTENANCE INFORMATION	FIRMWARE	FACTORY RESET
<ul style="list-style-type: none"> <li>SIOL-EI8B STRIDE IO-Link</li> <li>Basic DIO8 IOL8</li> <li>IO-Link Master Port X0</li> <li>IO-Link Master Port X1</li> <li>IO-Link Master Port X2</li> <li>IO-Link Master Port X3</li> <li>IO-Link Master Port X4</li> <li>IO-Link Master Port X5</li> <li>IO-Link Master Port X6</li> <li>IO-Link Master Port X7</li> <li>Digital IO Channels</li> <li><b>Settings / Maintenance</b></li> <li>User Administration</li> <li>Sign Out</li> </ul>	<p>Collapse all Expand all Refresh</p> <p>▼ Maintenance information</p> <p>Name: <input type="text" value="MAXI"/></p> <p>Installation location: <input type="text" value="HALL 123"/></p> <p>Installation date (yyyy-mm-dd): <input type="text" value="2021-08-12"/></p> <p>Contact information: <input type="text" value="SMITH"/></p> <p>Description: <input type="text" value="First Test"/></p> <p>Last service date (yyyy-mm-dd): <input type="text" value="2021-08-12"/></p> <p>Next service date (yyyy-mm-dd): <input type="text" value="2022-08-12"/></p> <p>Apply</p>			

Fig. 10-17: Setting maintenance information.

The maintenance information appears in the device under the menu item “Status” and submenu “Maintenance information”.

Station Name / Station Type	STATUS	PARAMETERS	DIAGNOSTICS	MAINTENANCE
<ul style="list-style-type: none"> <li>SIOL-EI8B STRIDE IO-Link</li> <li>Basic DIO8 IOL8</li> <li>IO-Link Master Port X0</li> <li>IO-Link Master Port X1</li> <li>IO-Link Master Port X2</li> <li>IO-Link Master Port X3</li> <li>IO-Link Master Port X4</li> <li>IO-Link Master Port X5</li> <li>IO-Link Master Port X6</li> <li>IO-Link Master Port X7</li> <li>Digital IO Channels</li> <li>Settings / Maintenance</li> <li>User Administration</li> <li>Sign Out</li> </ul>	<p>Collapse all Expand all Refresh</p> <ul style="list-style-type: none"> <li>▶ Vendor information</li> <li>▶ Device information</li> <li>▶ Device version</li> <li>▼ Maintenance information                             <ul style="list-style-type: none"> <li>- Name: MAXI</li> <li>- Installation location: HALL 123</li> <li>- Contact information: SMITH</li> <li>- Description: First Test</li> <li>- Last service date (yyyy-mm-dd): 2021-08-12</li> <li>- Next service date (yyyy-mm-dd): 2022-08-12</li> </ul> </li> <li>▶ Device status</li> </ul>			

Fig. 10-18: Maintenance information status.

### 10.4.3. FIRMWARE menu

This menu item displays the data of the firmware running on the device. Users with service, maintenance and admin rights can upload new firmware, provided in ZIP folders, to the device. After a successful upload, the device checks the firmware container and automatically starts with the new firmware version.

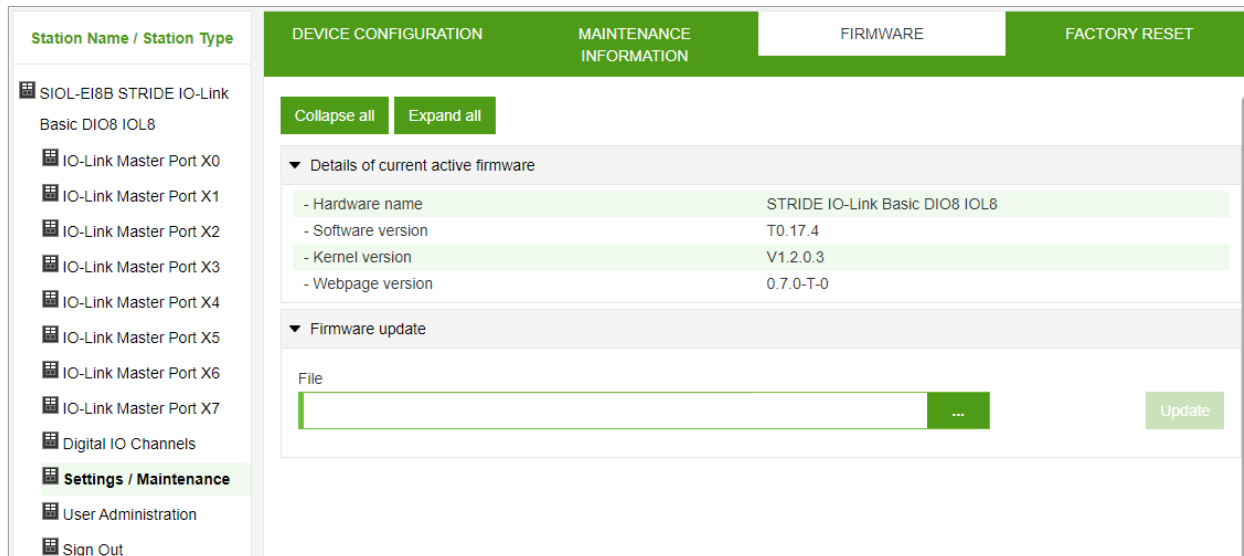

Fig. 10-19: Firmware.

### 10.4.4. FACTORY RESET menu

In this menu item, users with service, maintenance and admin rights can reset the entire module or restart/reboot the module.

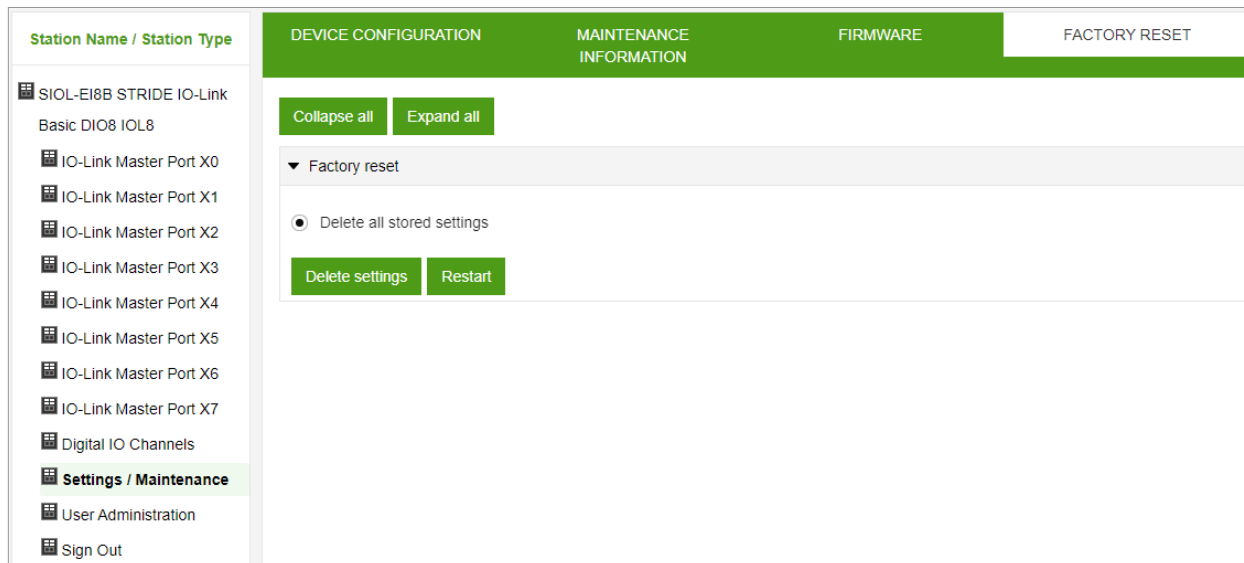

Fig. 10-20: Factory reset.

## 10.5. User Administration

User management can only be performed with admin rights.

The factory default administrator account is “admin” and the password is “private”.



### NOTE

The default administrator password can be changed from the controller in the plant with the fieldbus running.

Users log in and out at the bottom left of the system tree.

Account		Actions
admin	Admin	✖
Peter	Operator	✖
Service	Maintenance	✖
<input type="text" value="Username"/>	<input type="text" value="Password"/>	Maintenance +

Fig. 10-21: User management.

## 10.6. Digital IO Channels / IO Overview

In the “Configuration” menu of the selected IO-Link port, the setting for pin 2 and pin 4 is indicated at the selected port. Outputs can be set under certain conditions.

### 10.6.1. Input data

Every user can observe the digital states of the inputs configured on the device.

IO OVERVIEW	
Collapse all Expand all	
▼ Input data	
Port X1 Pin 4 (Channel 01)	Disabled
Port X2 Pin 4 (Channel 02)	Disabled
▶ Allow forcing outputs	
▶ Output data	

Fig. 10-22: Input data overview.

## 10.6.2. Output data

### Allow forcing outputs

Users with admin, service and maintenance rights can allow/enable forcing of outputs in this menu.

The right to do this is only granted if the module is not in an active fieldbus connection with the controller. The controller always has priority.

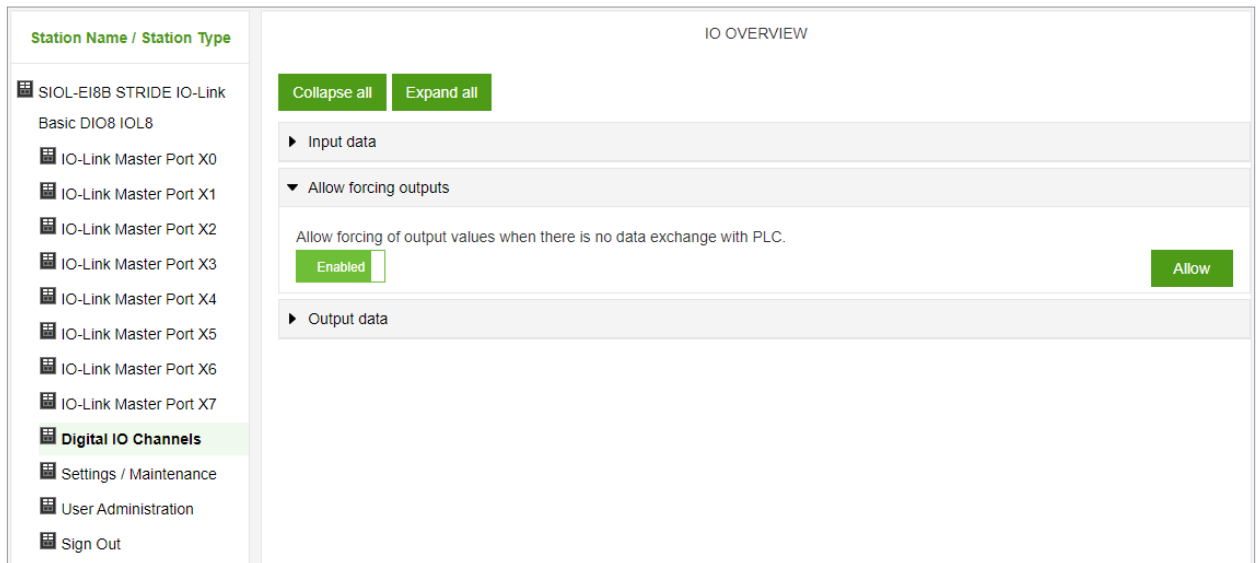

Fig. 10-23: Allow forcing outputs.

### Setting of output data

Guest users are not allowed to force outputs.

All other users (admin, operator, maintenance) are allowed to force outputs.

As soon as the user (admin, operator, maintenance) logs out, the outputs default to “0”.

As soon as a fieldbus is actively working with the module, the outputs go to “0” and then adopt the status they receive from the controller.

The screenshot shows the 'IO OVERVIEW' section of the web interface. On the left is a navigation menu with items like 'Station Name / Station Type', 'SIOL-EI8B STRIDE IO-Link', 'Basic DIO8 IOL8', 'IO-Link Master Port X0' through 'X7', 'Digital IO Channels', 'Settings / Maintenance', 'User Administration', and 'Sign In'. The main content area has a title 'IO OVERVIEW' and two buttons: 'Collapse all' and 'Expand all'. Below these are sections for 'Input data', 'Allow forcing outputs', and 'Output data'. Under 'Output data', there is a green banner with the text 'NOTE: For user role 'Guest', output forcing is not allowed!'. Below the banner is a list of seven output channels, each with a 'Disabled' button:

- Port X0 Pin 2 (Channel 10) - Disabled
- Port X1 Pin 2 (Channel 11) - Disabled
- Port X2 Pin 2 (Channel 12) - Disabled
- Port X3 Pin 2 (Channel 13) - Disabled
- Port X4 Pin 2 (Channel 14) - Disabled
- Port X5 Pin 2 (Channel 15) - Disabled
- Port X6 Pin 2 (Channel 16) - Disabled
- Port X7 Pin 2 (Channel 17) - Disabled

Fig. 10-24: Force output data.

## 11. Maintenance and cleaning

### NOTICE

#### Damage caused by defective or damaged devices!

The functioning of the modules is not guaranteed.

- Replace defective or damaged devices.

#### Device cleaning:

- Use only oil-free compressed air or spirit
- Only use lint-free materials (e.g. leather cloth)
- Do not use contact spray

## Appendix A: Supported EtherNet/IP objects

This chapter is an enumeration of the CIP objects and services supported by and implemented in this product. For more detailed descriptions of the individual objects and attributes, please refer to the EtherNet/IP specification.

### A.1. Standard object class

#### A.1.1. Identity Object (Class Code: 0x01)

##### Class Attribute

Identity Object Class Attribute					
Attribute ID	Access Rule	Name	Data Type	Attribute Description	Semantics of Value
1	Get	Revision	UINT	Revision of this object	The current value assigned to this attribute is two (02). In case of updates that require an increase in this value, the value of this attribute increases by 1.
2	Get	Max Instance	UINT	Maximum instance number of an object currently created in this class level of the device.	The largest instance number of a created object at this class hierarchy level. The value currently assigned to this attribute is one (01).
6	Get	Max ID Class Attribute	UINT	The attribute ID number of the last class attribute of the class definition implemented in the device.	The value of this attribute will be seven (07).
7	Get	Max ID Instance Attributes	UINT	The attribute ID number of the last instance attribute of the class definition implemented in the device.	The value of this attribute will differ by product variant. This attribute will show nine (09).

##### Instance Attribute

Identity Object Instance Attribute					
Attribute ID	Access Rule	Name	Data Type	Attribute Description	Value
1	Get	Vendor ID	UINT	Identification of each vendor by number	640
2	Get	Device Type	UINT	Indication of general type of product	12
3	Get	Product Code	UINT	Identification of a particular product of an individual vendor	
4	Get	Revision	STRUCT of:	Revision of the item the Identity Object represents	
		Major Revision	USINT		1
		Minor Revision	USINT		1
5	Get	State	WORD	Summary status of device	
6	Get	Serial Number	UDINT	Serial number of device	
7	Get	Product Name	SHORT_STRING	Human readable identification	
8	Get	State	USINT	Present state of the device as represented by the state transition diagram	

## Common Services

Identity Object Common Services				
Service Code	Implemented for		Service Name	Service Description
	Class	Instance		
0x01	No	Yes	Get_Attribute_All	Returns a predefined listing of this objects attributes.
0x05	No	Yes	Reset	Invokes the Reset service for the device. Option 0 restarts the device. Option 1 invokes a factory reset of the device.
0x0E	Yes	Yes	Get_Attribute_Single	Returns the contents of the specified attribute.

## A.1.2. Message Router Object (Class Code: 0x02)

This Object has no accessible attributes.

## A.1.3. Assembly Object (Class Code: 0x04)

## Class Attribute

Assembly Object Class Attribute					
Attribute ID	Access Rule	Name	Data Type	Attribute Description	Semantics of Value
1	Get	Revision	UINT	Revision of this object	The current value assigned to this attribute is one (01). If updates that require an increase in this value are made, then the value of this attribute increases by 1.

## Instance Attribute

Assembly Object Instance Attribute					
Attribute ID	Access Rule	Name	Data Type	Attribute Description	
3	Set,Get	Data	ARRAY of BYTE		
4	Get	Size	UINT	Number of bytes in Attribute 3	

## Common Services

Assembly Object Common Services				
Service Code	Implemented for		Service Name	Service Description
	Class	Instance		
0x0E	Yes	Yes	Get_Attribute_Single	Returns the contents of the specified attribute.
0x10	No	Yes	Set_Attribute_Single	Modifies an attribute value.

#### A.1.4. Connection Manager Object (Class Code: 0x06)

##### Class Attribute

Ethernet Link Object Class Attribute					
Attribute ID	Access Rule	Name	Data Type	Attribute Description	Semantics of Value
1	Get	Revision	UINT	Revision of this object	The current value assigned to this attribute is one (01). If updates that require an increase in this value are made, then the value of this attribute increases by 1.
2	Get	Max Instance	UINT	Maximum instance number of an object currently created in this class level of the device.	The largest instance number of a created object at this class hierarchy level. This attribute will show one (01).

##### Instance Attribute

There are no Instance Attributes implemented for this object.

##### Common Services

Ethernet Link Object Common Services				
Service Code	Implemented for		Service Name	Service Description
	Class	Instance		
0x0E	Yes	No	Get_Attribute_Single	Returns the contents of the specified attribute.

#### A.1.5. Device Level Ring (DLR) Object (Class Code: 0x47)

##### Class Attribute

Device Level Ring Object Class Attribute					
Attribute ID	Access Rule	Name	Data Type	Attribute Description	Semantics of Value
1	Get	Revision	UINT	Revision of this object	The current value assigned to this attribute is three (03). If updates that require an increase in this value are made, then the value of this attribute increases by 1.

##### Instance Attribute

Device Level Ring Object Instance Attribute				
Attribute ID	Access Rule	Name	Data Type	Attribute Description
1	Get	Network Topology	USINT	Current network topology mode
2	Get	Network State	USINT	Current status of network
10	Get	Active Supervisor Address	STRUCT of:	IP and/or MAC address of the active ring supervisor
			UDINT	Supervisor IP Address
			ARRAY of 6 USINTs	Supervisor MAC Address
12	Get	Capability Flags	USINT	Describes the DLR capabilities of the device

## Common Services

Device Level Ring Object Common Services				
Service Code	Implemented for		Service Name	Service Description
	Class	Instance		
0x01	No	Yes	Get_Attribute_All	Returns a predefined listing of this objects attributes.
0x0E	Yes	Yes	Set_Attribute_Single	Returns the contents of the specified attribute.

## A.1.6. Quality of Service Object (Class Code: 0x48)

## Class Attribute

Quality of Service Object Class Attribute					
Attribute ID	Access Rule	Name	Data Type	Attribute Description	Semantics of Value
1	Get	Revision	UINT	Revision of this object	The current value assigned to this attribute is one (01). If updates that require an increase in this value are made, then the value of this attribute increases by 1.
2	Get	Max Instance	UINT	Maximum instance number of an object currently created in this class level of the device.	The largest instance number of a created object at this class hierarchy level. This attribute will show one (01).

## Instance Attribute

Quality of Service Object Instance Attribute				
Attribute ID	Access Rule	Name	Data Type	Attribute Description
1	Set, Get	802.1Q Tag Enable	USINT	Enables or disables sending 802.1Q frames on CIP and IEEE 1588 messages.
4	Set, Get	DSCP Urgent	USINT	DSCP value for CIP transport class 0/1 Urgent priority messages.
5	Set, Get	DSCP Scheduled	USINT	DSCP value for CIP transport class 0/1 Scheduled priority messages.
6	Set, Get	DSCP High	USINT	DSCP value for CIP transport class 0/1 High priority messages.
7	Set, Get	DSCP Low	USINT	DSCP value for CIP transport class 0/1 low priority messages.
8	Set, Get	DSCP Explicit	USINT	DSCP value for CIP explicit messages (transport class 2/3 and UCMM) and all other EtherNet/IP encapsulation messages.

## Common Services

Quality of Service Object Common Services				
Service Code	Implemented for		Service Name	Service Description
	Class	Instance		
0x0E	Yes	Yes	Get_Attribute_Single	Returns the contents of the specified attribute.
0x10	No	Yes	Set_Attribute_Single	Modifies the contents of the attributes of the class or object.

### A.1.7. TCP/IP Interface Object (Class Code: 0xF5)

#### Class Attribute

TCP/IP Interface Object Class Attribute					
Attribute ID	Access Rule	Name	Data Type	Attribute Description	Semantics of Value
1	Get	Revision	UINT	Revision of this object	The current value assigned to this attribute is four (04). If updates that require an increase in this value are made, then the value of this attribute increases by 1.
2	Get	Max Instance	UINT	Maximum instance number of an object currently created in this class level of the device,	The largest instance number of a created object at this class hierarchy level. This attribute will show one (01).

#### Instance Attribute

TCP/IP Interface Object Instance Attribute				
Attribute ID	Access Rule	Name	Data Type	Attribute Description
1	Get	Status	USINT	Interface status
2	Get	Configuration Capability	USINT	Interface capability flags.
3	Set, Get	Configuration Capability	USINT	Interface control flags.
4	Get	Physical Link Object	STRUCT of	Path to physical link object.
		Path size	UINT	Size of Path
		Path	Padded EPATH	Logical segments identifying the physical link object.
5	Set, Get	Interface Configuration	STRUCT of	TCP/IP network interface configuration.
		IP Address	UDINT	The device's IP address.
		Network Mask	UDINT	The device's network mask.
		Gateway Address	UDINT	Default gateway address.
		Name Server	UDINT	Primary name server
		Name Server 2	UDINT	Secondary name server.
		Domain Name	STRING	Default domain name.
6	Set, Get	Host Name	STRING	Host name
10	Set, Get	SelectAcid	BOOL	Activates the use of ACD.
11	Set, Get	LastConflictDetected	STRUCT of	Structure containing information related to the last conflict detected.
		AcidActivity	USINT	State of ACD activity when last conflict detected.
		RemoteMAC	Array of 6 USINT	MAC address of remote node from the ARP PDU in which a conflict was detected.
		ArpPdu	ARRAY of 28 USINT	Copy of the raw ARP PDU in which a conflict was detected.
12	n.c.			
13	Get	Encapsulation Inactivity Timeout	UINT	Number of seconds of inactivity before TCP connection or DTLS session is closed.

#### Common Services

TCP/IP Interface Object Common Services				
Service Code	Implemented for		Service Name	Service Description
	Class	Instance		
0x01	No	Yes	Get_Attribute_All	Returns a predefined listing of this objects attributes.
0x0E	Yes	Yes	Get_Attribute_Single	Returns the contents of the specified attribute.
0x10	No	Yes	Set_Attribute_Single	Modifies a single attribute.

### A.1.8. Ethernet Link Object (Class Code: 0xF6)

#### Class Attribute

Ethernet Link Object Class Attribute					
Attribute ID	Access Rule	Name	Data Type	Attribute Description	Semantics of Value
1	Get	Revision	UINT	Revision of this object.	The current value assigned to this attribute is four (04). If updates that require an increase in this value are made, then the value of this attribute increases by 1.
2	Get	Max Instance	UINT	Maximum instance number of an object currently created in this class level of the device.	The largest instance number of a created object at this class hierarchy level. This attribute will show two (02).
3	Get	Number of Instances	UINT	Number of object instances currently created at this class level of the device.	The number of object instances at this class hierarchy level. This attribute will show two (02).

## Instance Attribute

Ethernet Link Object Instance Attribute				
Attribute ID	Access Rule	Name	Data Type	Attribute Description
1	Get	Interface Speed	USINT	Interface speed currently in use.
2	Get	Interface Flags	USINT	Interface status flags.
3	Get	Physical Address	USINT	MAC layer address.
4	Get	Interface Counters	STRUCT of	
		In Octets	UDINT	Octets received on the interface.
		In Ucast Packets	UDINT	Unicast packets received on the interface.
		In NUCast Packets	UDINT	Non-unicast packets received on the interface.
		In Discards	UDINT	Inbound packets received on the interface but discarded.
		In Errors	UDINT	Inbound packets that contain errors (does not include In Discards).
		In Unknown Protos	UDINT	Inbound packets with unknown protocol.
		Out Octets	UDINT	Octets sent on the interface.
		Out Ucast Packets	UDINT	Unicast packets sent on the interface.
		Out NUCast Packets	UDINT	Non-unicast packets sent on the interface.
		Out Discards	UDINT	Outbound packets discarded.
		Out Errors	UDINT	Outbound packets that contain errors.
5	Get	Media Counters	STRUCT of	Media-specific counters
		Alignment Errors	UDINT	Frames received that are not an integral number of octets in length.
		FCS Errors	UDINT	Frames received that do not pass the FCS check.
		Single Collisions	UDINT	Successfully transmitted frames which experienced exactly one collision.
		Multiple Collisions	UDINT	Successfully transmitted frames which experienced more than one collision.
		SQE Test Errors	UDINT	Number of times SQE test error message is generated.
		Deferred Transmissions	UDINT	Frames for which first transmission attempt is delayed because the medium is busy.
		Late Collisions	UDINT	Number of times a collision is detected later than 512 bit-times into the transmission of a packet.
		Excessive Collisions	UDINT	Frames for which transmission fails due to excessive collisions.
		MAC Transmit Errors	UDINT	Frames for which transmission fails due to an internal MAC sublayer transmit error.
		Carrier Sense Errors	UDINT	Times that the carrier sense condition was lost or never asserted when attempting to transmit a frame.
		Frame Too Long	UDINT	Frames received that exceed the maximum permitted frame size.
		MAC Receive Errors	UDINT	Frames for which reception on an interface fails due to an internal MAC sublayer receive error.
6	Set, Get	Interface Control	STRUCT of	Configuration for physical interface.
		Control Bits	WORD	Interface Control Bits
		Forced Interface Speed	UINT	Speed at which the interface shall be forced to operate.
7	Get	Interface Type	USINT	Type of interface: twisted pair, fiber, internal, etc.
8	Get	Interface State	USINT	Current state of the interface: operational, disabled, etc.
9	Set, Get	Admin State	USINT	Administrative state: enable, disable.
10	Set, Get	Interface Label	SHORT_STRING	Human readable identification.

table continued on next page

Ethernet Link Object Instance Attribute (continued)				
Attribute ID	Access Rule	Name	Data Type	Attribute Description
11	Get	Interface Capability	STRUCT of	Indication of capabilities of the interface.
		Capability Bits	DWORD	Interface capabilities, other than speed/ duplex.
		Speed/Duplex Options	STRUCT of	Indicates speed/duplex pairs supported in the Interface Control attribute.
			USINT	Speed/Duplex Array Count.
			ARRAY of STRUCT of	Speed/Duplex Array
			UINT	Interface Speed
		UINT	Interface Duplex Mode	

### Common Services

Ethernet Link Object Common Services				
Service Code	Implemented for		Service Name	Service Description
	Class	Instance		
0x01	No	Yes	Get_Attribute_All	Returns a predefined listing of this objects attributes.
0x0E	Yes	Yes	Get_Attribute_Single	Returns the contents of the specified attribute.
0x4C	No	Yes*	Set_Attribute_Single	Gets then clears the specified attribute.

\*The Get\_and\_Clear service is only implemented for the attributes 4 and 5.

## A.2. Vendor Specific Objects

### A.2.1. IO-Link Device Parameter Object (Class Code 0x83)

#### Class Attribute

IO-Link Device Parameter Object Class Attribute					
Attribute ID	Access Rule	Name	Data Type	Attribute Description	Semantics of Value
1	Get	Revision	UINT	Revision of this object	The current value assigned to this attribute is one (01). If updates that require an increase in this value are made, then the value of this attribute increases by 1.
2	Get	Max Instance	UINT	Maximum instance number of an object currently created in this class level of the device.	The largest instance number of a created object at this class hierarchy level. This attribute will show one (01).
6	Get	Max ID Class Attribute	UINT	The attribute ID number of the last class attribute of the class definition implemented in the device.	The value of this attribute will be seven (07).
7	Get	Max ID Instance Attributes	UINT	The attribute ID number of the last instance attribute of the class definition implemented in the device.	The value of this attribute will differ by product variant.

#### Instance Attribute

Instance attributes are not supported.

## Object-Specific Services

The following class-specific services are defined for the IO-Link Device Parameter Object.

Common Services of Object-Specific Services				
Service Code	Implemented for		Service Name	Service Description
	Class	Instance		
0x4B	No	Yes	Read_ISDU	Read the parameter in the IO-Link Device in raw format. i.e. Big Endian
0x4C	No	Yes	Write_ISDU	Write the parameter in the IO-Link Device in raw format i.e. Big Endian

### Read\_ISDU Service

Read_ISDU Service Structure		
Name	Data Type	Description
Index	UINT	IO-Link device index
Subindex	USINT	IO-Link device subindex

### Write\_ISDU Service

Write_ISDU Service Structure		
Name	Data Type	Description
Index	UINT	IO-Link device index
Subindex	USINT	IO-Link device subindex
Data	ARRAY of USINT	IO-Link device ISDU data

## Appendix B: Explanation of the process data



**NOTE**

The addresses shown in the tables in Appendix B use 0-based addressing. The Productivity Suite software uses 1-based addressing. So, add 1 to any address in these tables when accessing these values in Productivity Suite.

### Digital Input

The order of the digital input data depends on the configuration parameter “Pin\_Port\_based\_IO\_Layout”. This is explained in the following tables:

#### Port Based

Port-Based Digital Input																
Byte	1								0							
Bit	7	6	5	4	3	2	1	0	7	6	5	4	3	2	1	0
Port	X7	X7	X6	X6	X5	X5	X4	X4	X3	X3	X2	X2	X1	X1	X0	X0
Pin	2	4	2	4	2	4	2	4	2	4	2	4	2	4	2	4
Channel	17	07	16	06	15	05	14	04	13	03	12	02	11	01	10	00

#### Pin Based

Pin-Based Digital Input																
Byte	1								0							
Bit	7	6	5	4	3	2	1	0	7	6	5	4	3	2	1	0
Port	X7	X6	X5	X4	X3	X2	X1	X0	X7	X6	X5	X4	X3	X2	X1	X0
Pin	2	2	2	2	2	2	2	2	4	4	4	4	4	4	4	4
Channel	17	16	15	14	13	12	11	10	07	06	05	04	03	02	01	00



**NOTE**

The tables for Port and Pin Based are also applicable to Digital Input Qualifier, Digital Output Qualifier and Digital Output.

### B.1. System Status

The system state bit string provides information about the entire device.

System Status Bit String	
Byte	Description
0–3	Bit 0: Bus/sensor supply undervoltage Bit 1: Actuator supply undervoltage Bit 3: External error Bit 4: At least one channel has a sensor short circuit Bit 5: At least one channel has an actuator short circuit Bit 6: At least one channel has an actuator warning Bit 7: At least one analog channel has an error Bit 8: Internal communication error Bit 9: At least one IO-Link channel has an error (except wire break) Bit 10: Bus/sensor supply overvoltage Bit 11: Actuator supply overvoltage Bit 12: At least one IO-Link channel has a wire break Bit 13–31: Reserved, set to 0

## B.2. IO-Link Port X Status

IO-Link Port X Status		
Byte	Description	Value
0–1	IO-Link Data Status	Bit 0–4: reserved Bit 5: DevCom, is set when a device is detected and is in the PREOPERATE or OPERATE state. It is reset if no device is present. Bit 6: DevErr, is set when an error or warning has occurred that is assigned to either a device or a port. It is reset when there is no error or warning. Bit 7: PQ, is set when valid process data is exchanged between master and device. It is reset if the process data is not valid.
2–3	Vendor ID of connected IO-Link device	
4–7	Device ID of connected IO-Link device	

## B.3. Diagnostic Buffer

The diagnostic buffer consists of an array of diagnostic structures and has a length of 8 structures. A diagnostic structure has the size of 8 bytes. The total length of the diagnostic buffer is 64 bytes.



For further information on a diagnostic structure, please refer to [Section 9.2.3.7, “IO-Link device diagnostic”](#).

## B.4. Digital Output



The order of the digital output data depends on the configuration parameter “Pin\_Port\_based\_IO\_Layout”. See [Section B.1, “Digital Input”](#).

## Appendix C: Configuring a Module Using Studio5000 Logix Designer from Rockwell Automation

### C.1. Loading the EDS files

Installing the EDS files and/or the module description file.

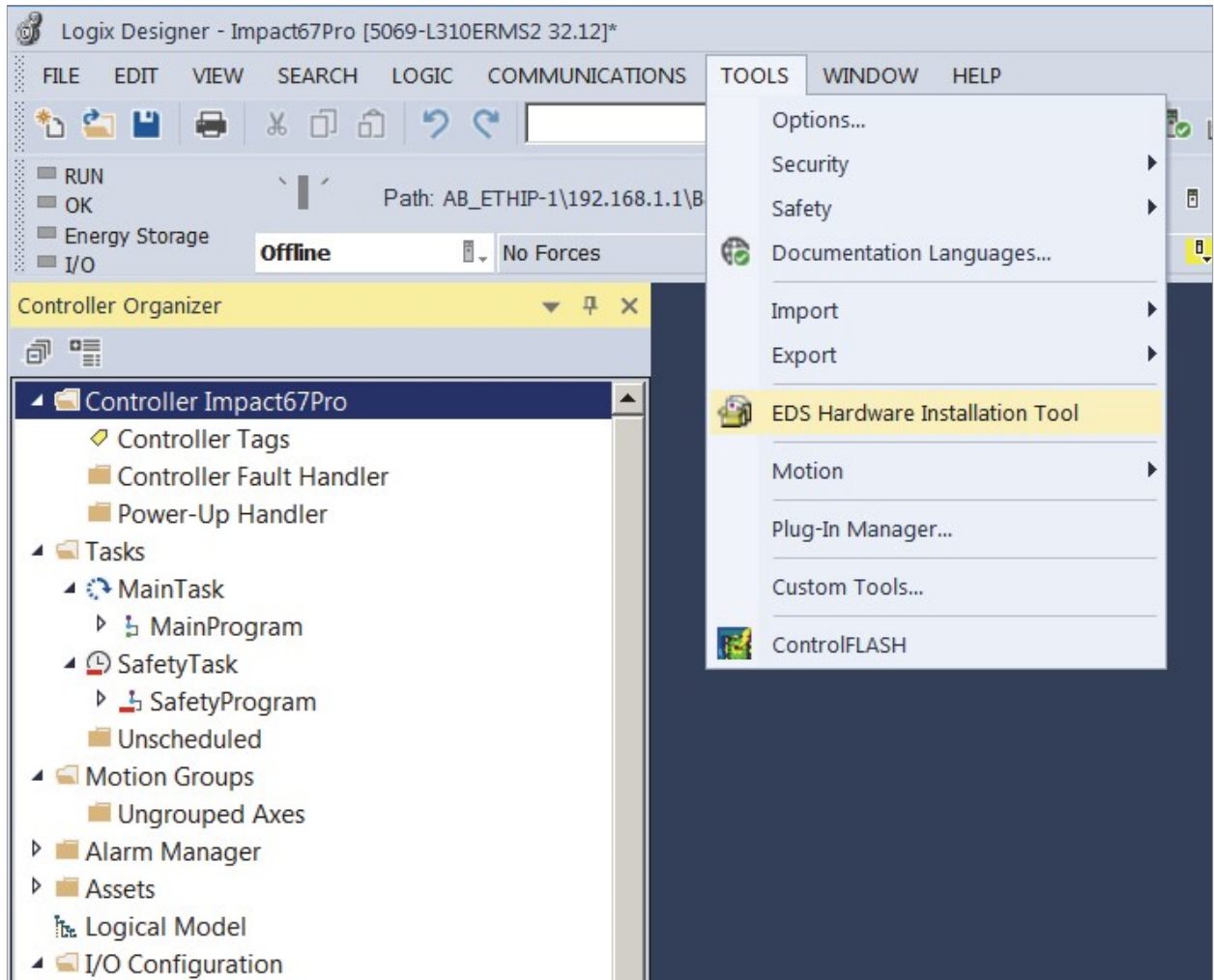

Fig. C-1: Loading the EDS files.

In **Project** menu | **Tools**,

→ click **EDS Hardware Installation Tool**.

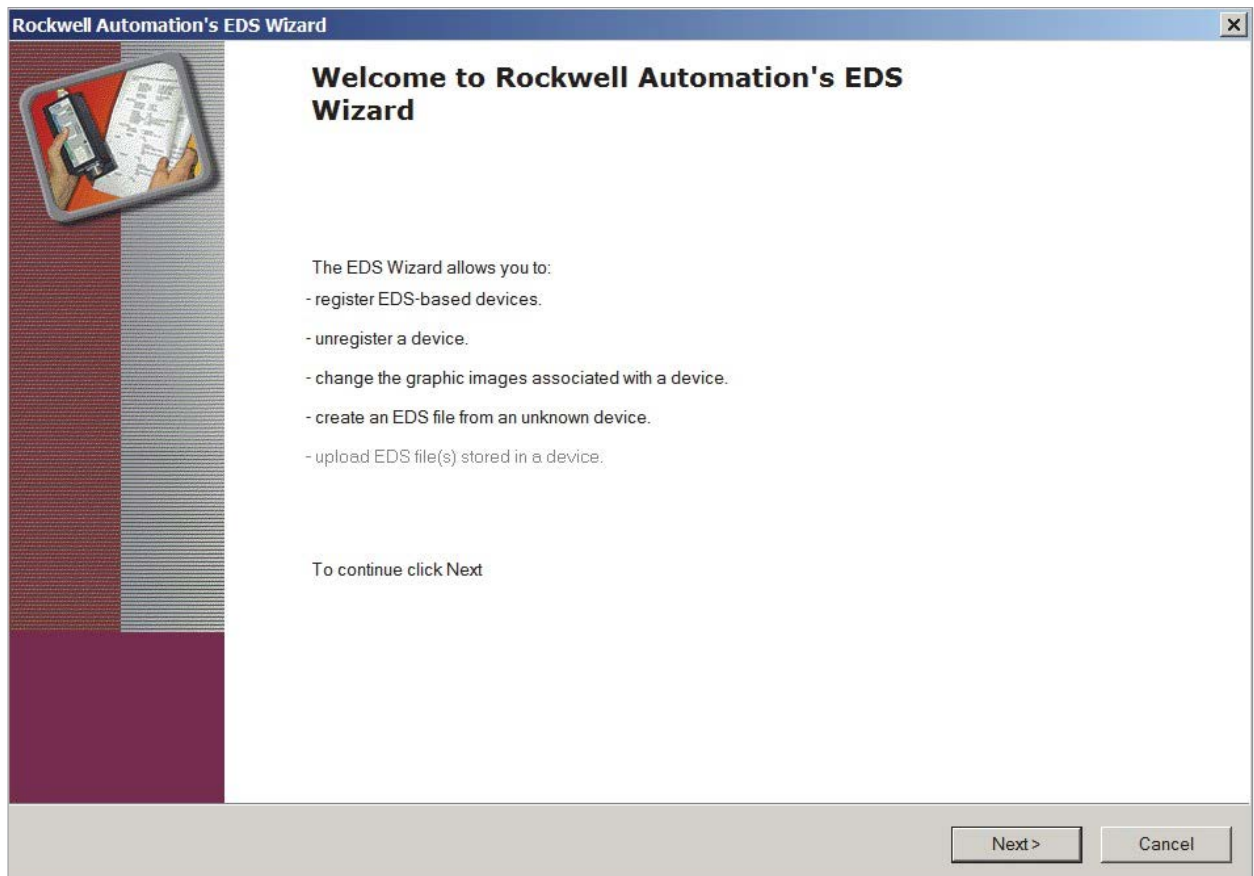

Fig. C-2: EDS Wizard.

- Click **Next** and follow the instructions of the dialog window.
- Finish the installation of the EDS files.

*The modules can now be selected and added to the network.*



**NOTE**

The EDS file can be found at <https://go2adc.com/iolink> under the part number of the module.

## C.2. Adding a module to the network

### Adding new modules

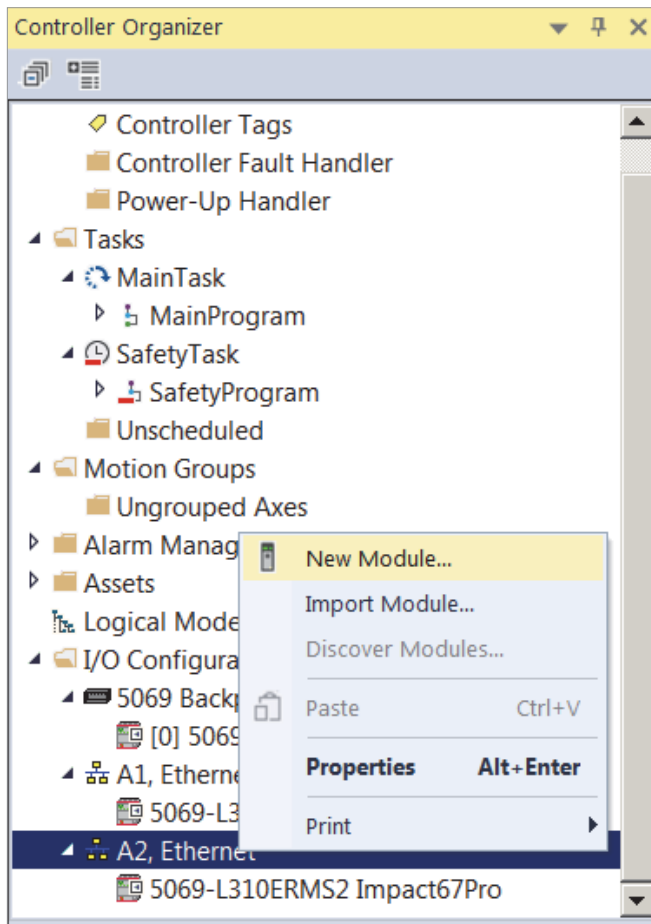

Fig. C-3: New Module.

In the **Controller Organizer | Ethernet**

→ Click **New Module**.

In the following dialog window, modules are shown which

a | have been registered previously with an EDS or

b | have already been delivered with the installation of the engineering software.

**Alternative module selection**

The dialog window can also be called via the menu **Files | New Component | Module**.

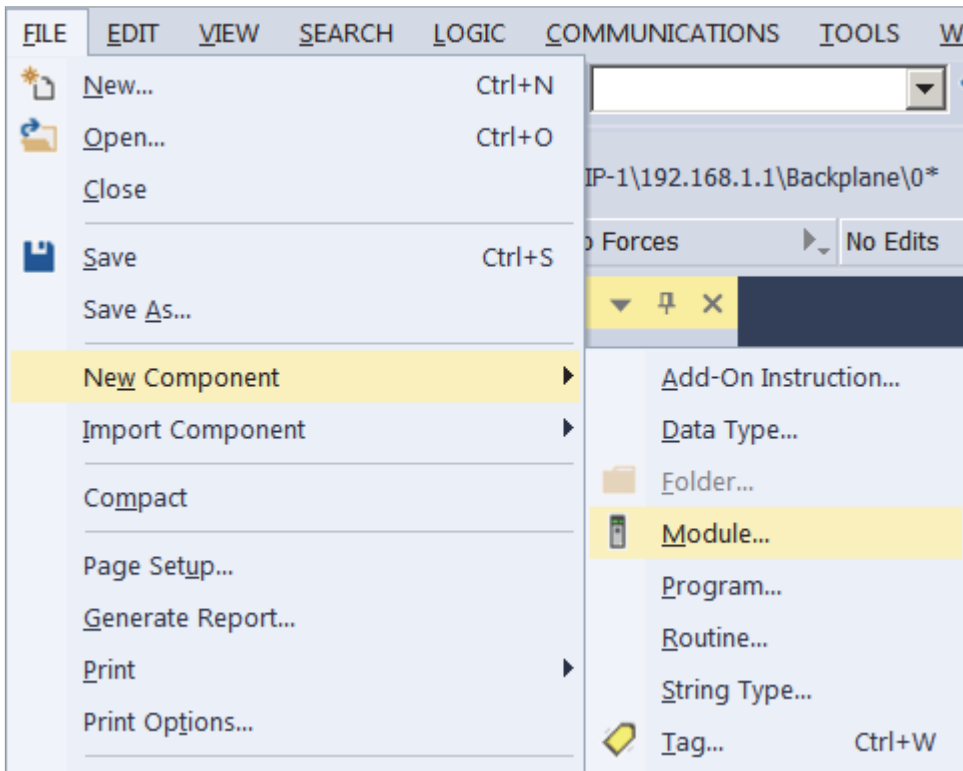

*Fig. C-4: Alternative module selection.*

## Searching a module

Use the input mask to search for the module that you want to add to the network.

- a | Use search terms which describe the desired module, e.g. product number, product name or manufacturer.
- b | Use a filter from the dialog window.

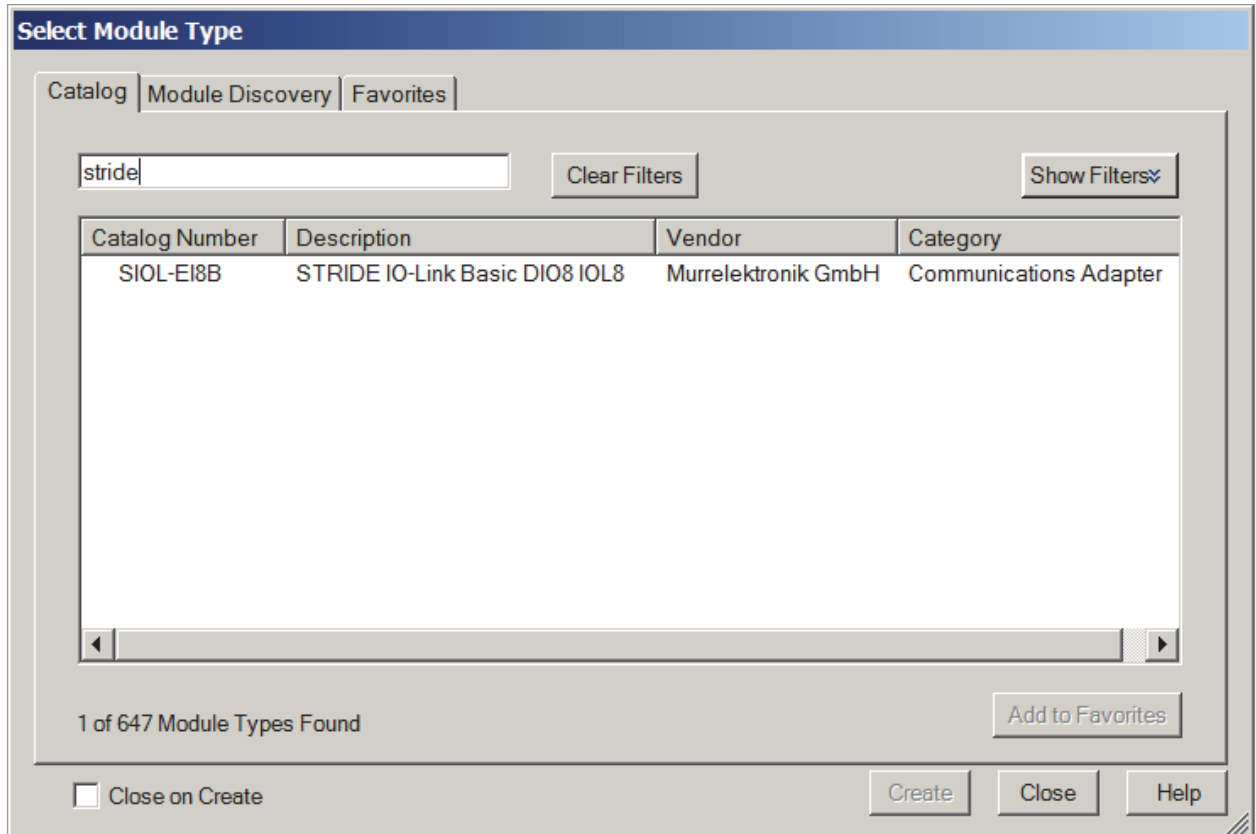

Fig. C-5: Searching for a module.

- Mark the module.
- Double-click **Create**.

## General settings

The screenshot shows the 'New Module' dialog box with the 'General' tab selected. The left sidebar contains a tree view with the following items: General, Connection, Module Info, Internet Protocol, Port Configuration, and Network. The main content area is titled 'General' and includes the following fields and sections:

- Type: SIOLEI8B STRIDE IO-Link Basic DIO8 IOL8
- Vendor: Murrelektronik GmbH
- Parent: Local
- Name: [Empty text box]
- Description: [Empty text area]
- Ethernet Address:
  - Private Network: 192.168.1. [Spinners]
  - IP Address: [IP Address text box]
  - Host Name: [Host Name text box]
- Module Definition:
  - Revision: 1.005
  - Electronic Keying: Compatible Module
  - Connections: Exclusive Owner (32B)

At the bottom of the Module Definition section is a 'Change ...' button. The status bar at the bottom left indicates 'Status: Creating'. At the bottom right are 'OK', 'Cancel', and 'Help' buttons.

Fig. C-6: General settings.

### In New Module | General

- Assign a unique module name.
- Assign the IP address.

### In New Module | Connection

- Assign further settings, e.g. the RPI settings.
- Add the module to the network by pressing **OK**.

## Selecting the connection

In order to choose the best connection for every application, you can choose from various connection options:

- a | when adding the module to the network, select the correct connection or
- b | call the settings again by double-clicking the module.

Module Definition

Revision: 1 005

Electronic Keying: Compatible Module

Connections:

Name	Input	Output	Size
Exclusive Owner (32B)	394	260	SINT

OK Cancel Help

Fig. C-7: Module Definition.

### In Module Definition

→ Click **Change**.

A new window appears.

→ Set the number or the type of connection here. (See [Section 7.4.2, "Connection matrix"](#).)

→ Click the preset connection (**Exclusive Owner**).

→ Select the connection that meets the requirements.

*The list of all connections that can be set is displayed.*



#### NOTE

The modules support up to 3 connections at a time (1 Exclusive Owner and 2 Non-Exclusive-Owner connections).

### C.3. Module configuration



**NOTE**

To transfer index changes via acyclic ISDU writes to the DataStorage, a ParamDownloadStore command must be sent after the index changes.

→ The ParamDownloadStore command can be triggered by writing value 0x05 to index 0x02.

#### Configuration via EDS

After the import of the EDS in the programming software and the selection of a connection suitable for the application, the configuration files can be found in the controller tags.

The input and output tags associated with the device can be found next to it.

STRIDE:C	{...}	{...}		_0280:SIOL_EI...
▸ STRIDE:C.Pin_Port_based_IO_layout_for_digital_cha	0		Decimal	SINT
▸ STRIDE:C.Diag_Param_Global_Diagnostic_Report	1		Decimal	SINT
▸ STRIDE:C.Diag_Param_Under_Voltage_Sensor_Supply	1		Decimal	SINT
▸ STRIDE:C.Diag_Param_Under_Voltage_Actuator_Suppl	1		Decimal	SINT
▸ STRIDE:C.Diag_Param_No_Actuator_Supply_Diagnosti	1		Decimal	SINT
▸ STRIDE:C.Diag_Param_LED_Indication_For_Suppresse	0		Decimal	SINT
▸ STRIDE:C.Diag_Param_Diagnostic_Message_Acknowled	0		Decimal	SINT
▸ STRIDE:C.Diag_Param_Port_X0_Diagnostic_Report	0		Decimal	SINT
▸ STRIDE:C.Diag_Param_Port_X1_Diagnostic_Report	0		Decimal	SINT
▸ STRIDE:C.Diag_Param_Port_X2_Diagnostic_Report	0		Decimal	SINT
▸ STRIDE:C.Diag_Param_Port_X3_Diagnostic_Report	0		Decimal	SINT
▸ STRIDE:C.Diag_Param_Port_X4_Diagnostic_Report	0		Decimal	SINT
▸ STRIDE:C.Diag_Param_Port_X5_Diagnostic_Report	0		Decimal	SINT
▸ STRIDE:C.Diag_Param_Port_X6_Diagnostic_Report	0		Decimal	SINT

Fig. C-8: Configuration via EDS.

All configuration tags have a specific name that describes the function of the areas.

→ Enter the appropriate values for your application.

Each time a connection with the control system is established, the device configuration is updated.



For more information on the adjustable values, please refer to [Section 7.4.4, “Configuration values”](#).

## C.4. RPI configuration

### Setting the RPI values

#### Searching the module

When setting up an EtherNet/IP system, the RPI value must be carefully set in the controller.

To set the RPI values, the module properties must be selected.

In **Controller Organizer**:

- Double-click the module *or*
- Right-click the module and select **Properties** from the context menu.

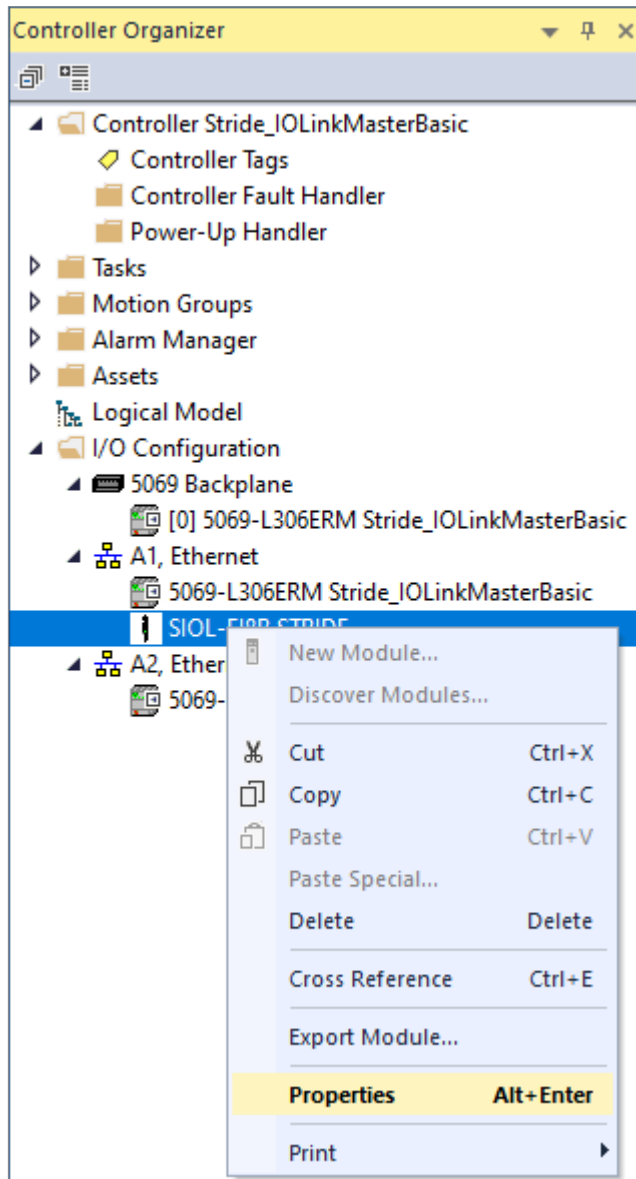

Fig. C-9: Searching a module.

## Setting the RPI values

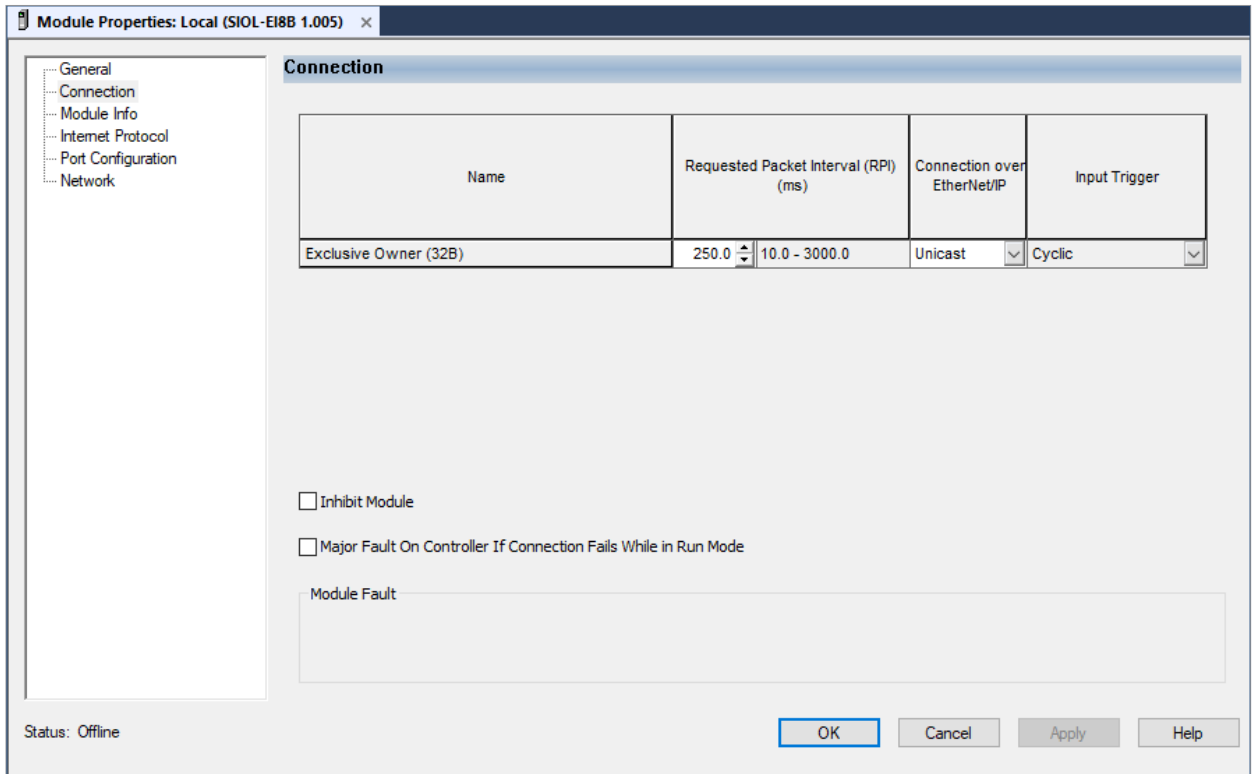

Fig. C-10: Setting the RPI values.

- Click the **Connection** tab.
- Set the desired RPI values in the column **Requested Packet Interval (RPI) (ms)**.

**NOTE**

The minimum RPI is 1 ms.

# Glossary

<b>Term</b>	<b>Meaning</b>
CIP	<p>Common Industrial Protocol</p> <p>The Common Industrial Protocol is an application protocol used in automation technology. It supports the transition between fieldbuses and industrial Ethernet and IP networks. This industrial protocol uses EtherNet/IP in the application layer as interface between fieldbus and control, I/O, etc.</p>
DHCP	<p>Dynamic Host Configuration Protocol</p> <p>DHCP allows a server to dynamically distribute IP address and configuration information to clients. Normally, the DHCP server provides at least the following basic information to the client:</p> <ul style="list-style-type: none"> <li>- IP address</li> <li>- Subnet mask</li> <li>- Standard gateway</li> </ul>
EDS	<p>Electronic Data Sheet</p> <p>An EDS file is an external file that contains information for a module. It provides necessary information for access to and change of configurable parameters of a module.</p>
Ethernet frame	<p>In each Ethernet frame (data package), there are addresses of transmitter (source) and receiver (target). When a frame is received, the receiving unit of a receiving station compares the MAC target address with its own MAC address. When the addresses match, the receiving unit forwards the contents of the frame to a superior layer. If they do not match, the frame is discarded.</p>
EtherNet/IP	<p>Ethernet Industrial Protocol</p> <p>Open standard for industrial networks that supports both cyclic and acyclic transfer of messages and uses standard Ethernet communication chips and physical media.</p>
IO-Link IOL	<p>Standardized communication system to connect intelligent sensors and actuators to an automation system</p>
IP	<p>Internet Protocol</p> <p>Protocol used for transferring data within a network, e.g. internet or intranet, from one computer to another. Each computer in the network can be clearly identified by means of its IP address. If data is sent from one computer to another, it is subdivided into small information packages containing each transmitter and receiver addresses. These packages can be sent over the network using different routes and arrive at their destination in a different order than the sequence of sending. Another protocol, the transmission control protocol [TCP], then restores the original order.</p>
MAC address	<p>Media Access Control Address</p> <p>Hardware address of network components used for clearly identifying devices in a network.</p>
ODVA	<p>ODVA is an international association for open and compatible information and communication technologies in automation systems.</p> <p>e.g., EtherNet/IP, DeviceNet, CompoNet and ControlNet, etc.</p>
RPI	<p>Requested packet interval</p> <p>The interval at which an EtherNet/IP target sends process data to the scanner.</p>

## Legal notes

### Disclaimer

Murrelektronik GmbH has reviewed the contents of this technical documentation for conformity with the described hardware and software. It is possible that certain details may not be correct. For this reason, we make no warranty regarding the accuracy of this technical documentation, and assume no liability for any errors, in particular full conformity. This exclusion of liability shall not apply if the damage was caused deliberately and/or due to gross negligence, nor does it cover any claims based on the German Product Liability Act.

Should a major contractual obligation have been violated negligently, the liability of Murrelektronik GmbH shall be limited to typically occurring damage.

We reserve the right to make technical alterations and amend the content of this documentation. We recommend to regularly check whether this documentation has been updated because corrections that might be required due to technical modifications will be included by Murrelektronik GmbH at regular intervals. Please contact us if you would like to suggest any improvements.

### Copyright

It is prohibited to transfer or photocopy the documentation either in paper or in digital form, reuse or divulge its contents unless otherwise expressly permitted by Murrelektronik GmbH or in conjunction with the production of documentation for third-party products that contain products made by Murrelektronik GmbH. Compensation will be claimed if our copyright is violated. All rights reserved, particularly in the event of a patent being granted or a utility model being registered.

### Usage rights

Murrelektronik GmbH grants its customers a non-exclusive right revocable at any time and for an indefinite period of time to use this technical documentation to create their own technical documentation. For this purpose, the documentation produced by Murrelektronik GmbH may be changed in parts, or amended, or copied, and transferred to the customer's users as part of the customer's own technical documentation on paper or on electronic media. In this case, the customers shall bear sole responsibility for the correctness of the contents of the technical documentation produced by them.

If the technical documentation is integrated in part, or in full in the customer's technical documentation, the customer shall refer to the copyright of Murrelektronik GmbH. All safety instructions must be included.

Although the customer is obliged to make reference to the copyright of Murrelektronik GmbH, provided the technical documentation of Murrelektronik GmbH is used, the customers shall market and/or use the technical documentation on their sole responsibility. The reason is that we have no influence on changes or applications of the technical documentation and even minor changes to the initial product or deviations in the intended applications may render incorrect the specifications contained in the technical documentation. For this reason, the customer is obliged to label the technical documentation provided by Murrelektronik GmbH if and the extent to which the documentation is amended by the customer. The customers shall undertake to exempt Murrelektronik from claims for damages of third parties if the latter are attributable to any defects in the documentation. This shall not apply to damage to the rights of third parties caused deliberately or by gross negligence.

The customers shall be entitled to use the company brands of Murrelektronik GmbH exclusively for their product advertising, but only inasmuch as the products of Murrelektronik GmbH are integrated into the products marketed by the customers. When using Murrelektronik GmbH brands, the customers shall so state in an adequate manner.

Stride™

Powered by  MURR  
ELEKTRONIK

 AUTOMATIONDIRECT.com  
770-844-4200

Although the information in this manual has been compiled with utmost care, we are not responsible for the completeness and relevance of the information.